

UNIT 1

AIR CONDITIONING – PRINCIPLES AND SYSTEMS

SYLLABUS

- THERMODYNAMICS
- TRANSFER OF HEAT
- REFRIGERATION CYCLE COMPONENTS
- VAPOR COMPRESSION CYCLE
- REFRIGERANT
- COMPRESSOR
- CONDENSER
- EVAPORATOR
- REFRIGERANT CONTROL DEVICES
- ELECTRIC MOTORS
- AIR HANDLING UNITS
- COOLING TOWERS
- AIR CONDITIONING SYSTEMS FOR BUILDINGS OF DIFFERENT SCALES AND THEIR REQUIREMENTS
- WINDOW TYPE
- SPLIT SYSTEM
- PACKAGE UNIT
- DIRECT EXPANSION SYSTEM
- CHILLED WATER SYSTEM
- FAN COIL UNIT
- DISTRICT COOLING SYSTEMS
- ENERGY EFFICIENT SYSTEM
- ENVIRONMENTAL ASPECTS AND LATEST INNOVATIONS

PREREQUISITE

2nd Law of Thermodynamics

The second law of physics you need to know is the 2nd Law of Thermodynamics:

If you paid attention in school, you might remember that the second law of thermodynamics states that heat flows from hotter to colder bodies naturally. You can only transfer heat from a colder body to a warmer body through some kind of external work.

Air Conditioning : The Fundamentals

Air conditioners transfer heat from the indoors to the outdoors.

Although you may think that air conditioners create cold air, they actually extract heat from the indoor air and send it outside.

When heat is removed from the indoor air, the air is cooled down. It's best to think of the air conditioning process as heat flowing from the indoors to the outdoors.

The Refrigeration Cycle

An air conditioner works using a thermodynamic cycle called the refrigeration cycle. It does this by changing the pressure and state of the refrigerant to absorb or release heat.

The refrigerant absorbs heat from inside of your home and then pumps it outside.

Most air conditioners are air-source, split systems. What this means is that there is one unit inside and one unit outside, which is why it is called a split system.

Here are the basic parts of the refrigeration cycle (the same process that your refrigerator used to keep food cold):

1. Air flows over the indoor coils, which contain extremely cold refrigerant

When air flows over the cold coils, heat from the air gets transferred to the refrigerant inside the coils. After the air flows over the coils, it gets cold, normally dropping around 20 degrees.

This process follows the 2nd law of thermodynamics, which says that heat naturally (spontaneously) flows from a warmer body to a cooler body.

After the refrigerant absorbs the heat, its state changes from a liquid to a vapor. This warmer refrigerant gas then gets transferred to the compressor (step 2 in the refrigeration cycle).

2. Warmer, vaporized refrigerant gets compressed (pressurized) to a hot temperature

Even though the refrigerant has absorbed heat from the indoor air, it is still fairly cool. The still cool, but warmer vaporized gas enters the compressor (located in the outside unit) to increase its pressure and temperature.

We increase the temperature of the refrigerant because it needs to be warmer than the outdoor air. Remember the 2nd law of thermodynamics again—heat flows from warmer to cooler bodies.

If the refrigerant is 120 degrees and the outdoor air is 90 degrees, the outdoor air is cooler, which means the heat from the refrigerant will flow in the direction we want—outside. If the temperature outside is 120 degrees, the compressor will have to work extra hard to increase the temperature of the refrigerant to a higher temperature.

After the refrigerant's temperature is increased above that of the outdoor air's temperature, it then flows into another set of coils, known as the condenser coils (also located outside).

3. Very hot refrigerant flows into condenser coils where it loses heat to the outdoor air

Since the refrigerant has been compressed (pressurized), it is now hotter than the outdoor air. A condenser fan blows hot outdoor air over the even hotter outdoor condenser coils.

As outdoor air flows over the outdoor coils, heat is removed from the refrigerant and released into the outdoor air. Again, this is due to the 2nd law of thermodynamics.

After the refrigerant loses thermal energy to the outdoor air, it condenses back into a liquid and gets pumped back inside.

4. The still warm refrigerant from the outdoor unit needs to get cold

When the refrigerant leaves your outdoor condenser unit, its temperature is still pretty high. The refrigerant's temperature will need to drop significantly before it can absorb more heat from the indoor air.

The metering device, usually a thermostatic expansion valve, is a special device that depressurizes the refrigerant, causing a drop in temperature. It does this by expanding the refrigerant into a larger volume.

The refrigerant needs to be colder than the indoor air in order to absorb heat. Once the refrigerant gets cooled down, it flows back into the evaporator coils where it begins the refrigeration cycle again.

Hopefully, this helps you understand the basic workings of an air conditioner. The refrigeration cycle is basically the same for your freezer and refrigerator.

1.1 THERMODYNAMICS

Thermodynamics simply describes the movement of heat. Thermodynamics is derived from *thermo*, meaning heat, and *dynamics*, (literally “power”), and is used to describe the movement or change of a process due to heat flow.

Heat and temperature are often confused or used interchangeably. Heat is the flow of energy from one object or system, to another object or system. Temperature is a measure of the internal kinetic energy of an object. As an example, a frying pan has a high temperature because the molecules of the metal are moving quickly. When an egg is cracked into the pan, heat flows from the pan to the egg. Although not obvious, the temperature of the pan will drop slightly as it transfers heat to the egg.

THERMODYNAMIC LAWS

First Law - Energy cannot be created or destroyed, but can change form, and location. For instance, burning wood changes the internal energy in the wood into heat and light energy.

Second Law - The Second Law is the most understandable and useful in real world applications, and makes heating, air conditioning, and refrigeration possible. Energy must flow from a higher state to a lower state. That is, heat must always flow from the warmer object to a cooler object and not from the cooler object to the warmer object.

The Second Law holds in our everyday visible world, but on the subatomic level the law is constantly violated, but statistically the law holds true. Although beyond the scope of this article, an interested reader will find fascinating theories in quantum mechanics. A search of the “arrow of time” will yield interesting variations of the Second Law.

1.2 TRANSFER OF HEAT

Heat can move in three ways: conduction, convection, and radiation.

Conduction is the easiest and most familiar to anyone who has burned themselves on a stove or a hot pot. It is the direct transfer of heat from one object to another, when they are in contact. Since heat is the flow of energy, and it is driven by the temperature difference between two objects, an iron at 300° and a piece of dry ice at -110° will both burn a finger because the temperature difference between the finger and the iron or dry ice is about the same. In one case the flow of heat is into the finger, in the other the flow of heat is out of the finger, but in both the heat flow is high.

Convection is based on the movement of a fluid to transfer heat from one object or area to another. Weather is a convective process; hot air and warm water move from the tropics toward the poles.

Radiation is heat transferred directly from a source to an object without using a medium like air or water. Heat radiated from the sun will melt snow on the road, even on a cold day. The radiant energy warms the road surface without directly warming the air.

Moving heat from one object or area to another allows comfort heating and air conditioning, as well as refrigeration for food preservation and processes.

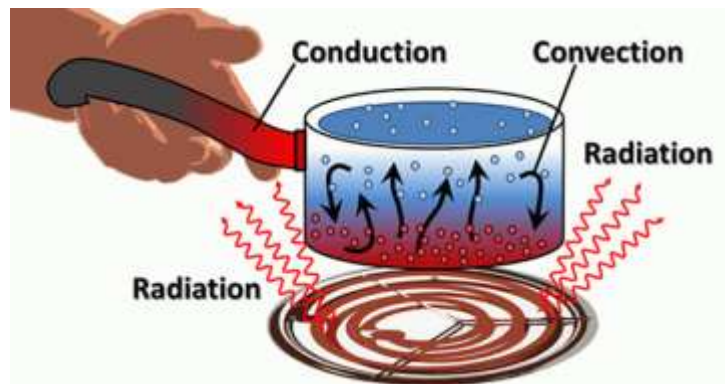

Change of State

- ✓ Most of the common substances can exist in three different forms, called states: solid, liquid and gas.
- ✓ The state will change when the substance is heated.
- ✓ As a solid, a substance has a fixed volume and shape and is usually unable to flow, except in the case of glaciers. For instance, an ice cube or snowflake is the solid state of water.
- ✓ When a solid is heated, it turns into a liquid. As a liquid, a substance has a fixed volume, but its shape changes to fill the shape of its container. For instance, a glass of water is the liquid state of water.
- ✓ When a liquid is heated, it turns into a gas. As a gas, a substance does not have a fixed volume or shape. Gas expands to fill the shape and volume of its container.

Sensible Heat

- Sensible heat is potential energy in the form of thermal energy or heat.
- The thermal body must have a temperature higher than its surroundings.
- The thermal energy can be transported via conduction, convection, radiation or by a combination thereof. In many cases the reference temperature is inferred from common knowledge, i.e. "room temperature".

Latent Heat

- latent heat is the amount of energy in the form of heat released or absorbed by a substance during a change of phase (i.e. solid, liquid, or gas) Two latent heats are typically described:

Latent heat of fusion (melting or freezing)

Latent heat of fusion is defined as the amount of heat required to convert a unit mass of the substance from solid to liquid form at its melting point without any rise temperature.

Latent heat of evaporation (boiling or condensation)

Latent heat of vapourization is defined as the amount of heat required to convert a unit mass of the substance from liquid into its vapor state at the same temperature.

Saturation temperature

- The condition of temperature and pressure at which both liquid and vapor can exist simultaneously is termed saturation.
- Saturation temperature is nothing but the temp at which addition of heat result in change of phase, for water the change of phase will result in vapor at saturation temperature and for steam the addition of heat result in superheated steam.

1.3 REFRIGERATION CYCLE COMPONENTS

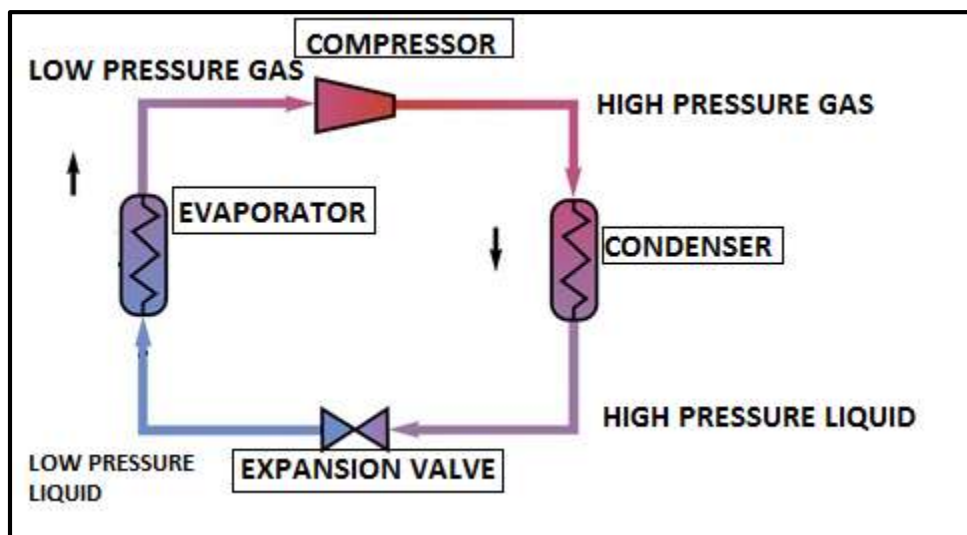

- The refrigerant comes into the COMPRESSOR as a low-pressure gas, it is compressed and then moves out of the compressor as a high-pressure gas.
- The gas then flows to the CONDENSER. Here the gas condenses to a liquid, and gives off its heat to the outside air.

- The liquid then moves to the EXPANSION VALVE under high pressure. This valve restricts the flow of the fluid, and lowers its pressure as it leaves the expansion valve.
- The low-pressure liquid then moves to the EVAPORATOR, where heat from the inside air is absorbed and changes it from a liquid to a gas.
- As a hot low-pressure gas, the refrigerant moves to the compressor where the entire cycle is repeated.
- The four-part cycle is divided at the centre into a high side and a low side. This refers to the pressures of the refrigerant in each side of the system.

1.4 VAPOR-COMPRESSION CYCLE

- ★ The Vapor Compression Cycle uses energy input to drive a compressor that increases the pressure and pressure of the refrigerant which is in the vapor state.
- ★ The refrigerant is then exposed to the hot section (termed the condenser) of the system, its temperature being higher than the temperature of this section.
- ★ As a result, heat is transferred from the refrigerant to the hot section (i.e. heat is removed from the refrigerant) causing it to condense i.e. for its state to change from the vapor phase to the liquid phase (hence the term condenser).
- ★ The refrigerant then passes through the expansion valve across which its pressure and temperature drop considerably.
- ★ The refrigerant temperature is now below that existing in the cold or refrigerated section (termed the evaporator) of the system, its temperature being lower than the temperature in this section. As a result, heat is transferred from the refrigerated section to the refrigerant (i.e. heat is absorbed by the refrigerant) causing it to pass from the liquid or near-liquid state to the vapor state again (hence the term evaporator).
- ★ The refrigerant then again passes to the compressor in which its pressure is again increased and the whole cycle is repeated.

The four basic components of the vapour compression refrigeration system are thus:

1. Compressor: The function of the compressor is to compress the input refrigerant of low pressure and low temperature. As a result the pressure and the temperature of the refrigerant increases. Generally reciprocating compressors are used in refrigeration system. An external motor is used to drive the compressor.

2. Condenser: The condenser is a coil of tubes, which are made of copper. This issued to condense the refrigerant which is in the form of vapor. And convert into liquid.

3. Expansion Valve: This is otherwise called throttle valve. This valve is used to control the flow rate of refrigerant and also to reduce the pressure of the refrigerant.

4. Evaporator: This is the part in which the cooling takes place. This is kept in the space where cooling is required. It is a coil of tubes made up of copper.

1.5 REFRIGERANT

Pressure temperature relationships for Liquid Refrigerants

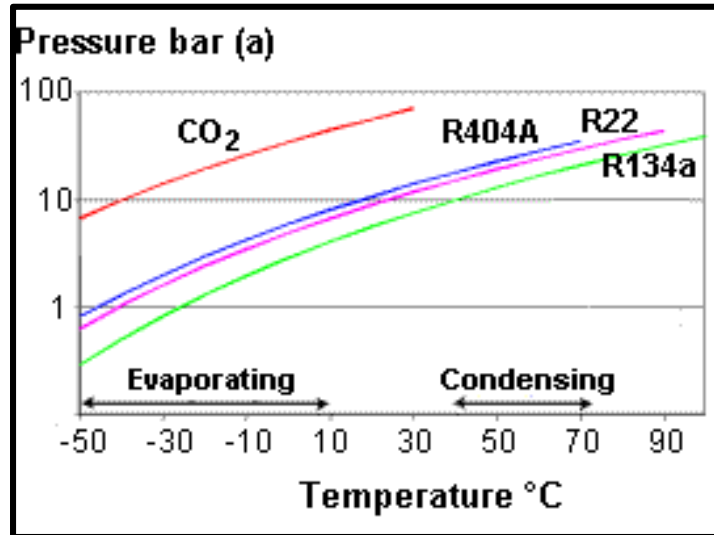

Choosing a Refrigerant

Each fluid has its own distinct boiling temperature - pressure characteristic. This is called the Saturation Pressure Temperature relationship, or P-T data for short. The normal boiling point is atmospheric pressure, which is approximately 1 bar(a).

R134a boils at -26°C

R22 boils at -40.8°C

R404A boils at -46°C

The curves show the evaporating or condensing temperature of each of these fluids together with carbon dioxide, over the range of temperatures of interest to refrigeration engineers. Normally it is necessary to choose a fluid which evaporates between, say, -50 and +10 °C and which condenses at 40 to 70 °C. The pressure for both processes should be greater than atmospheric - but not too high. Generally the higher the saturation pressure for a given temperature, the better the thermal capacity of the fluid. So less fluid is required to do the job. Unfortunately carbon dioxide will not condense at pressures above 70bar because this is the critical pressure.

- Temperature and pressure are directly proportional to each other.

- This means that as the temperature decreases, the pressure also decreases, and as the temperature increases, the pressure increases.
- One way to think of this is if you increase the speed of the molecules –by increasing their temperature- the force of the molecules hitting their container increases and this increases the pressure.
- The temperature at which a liquid boils is dependent on the pressure exerted on it.

1.6 COMPRESSOR

The purpose of the compressor is to circulate the refrigerant in the system under pressure; this concentrates the heat it contains.

At the compressor, the low pressure gas is changed to high pressure gas.

- The compressor has reed valves to control the entrance and exit of refrigerant gas during the pumping operation. These must be firmly seated.
- An improperly seated intake reed valve can result in gas leaking back into the low side during the compression stroke, raising the low side pressure and impairing the cooling effect.
- A badly seated discharge reed valve can allow condensing or head pressure to drop as it leaks past the valve, lowering the efficiency of the compressor.

Two service valves are located near the compressor as an aid in servicing the system. One services the high side, it is quickly identified by the smaller discharge hose routed to the condenser. One is used for the low side, the low side comes from the evaporator, and is larger than the discharge hose

The compressor is normally belt-driven from the engine crankshaft. Most manufacturers use a magnetic-type clutch which provides a means of stopping the pumping of the compressor when refrigeration is not desired.

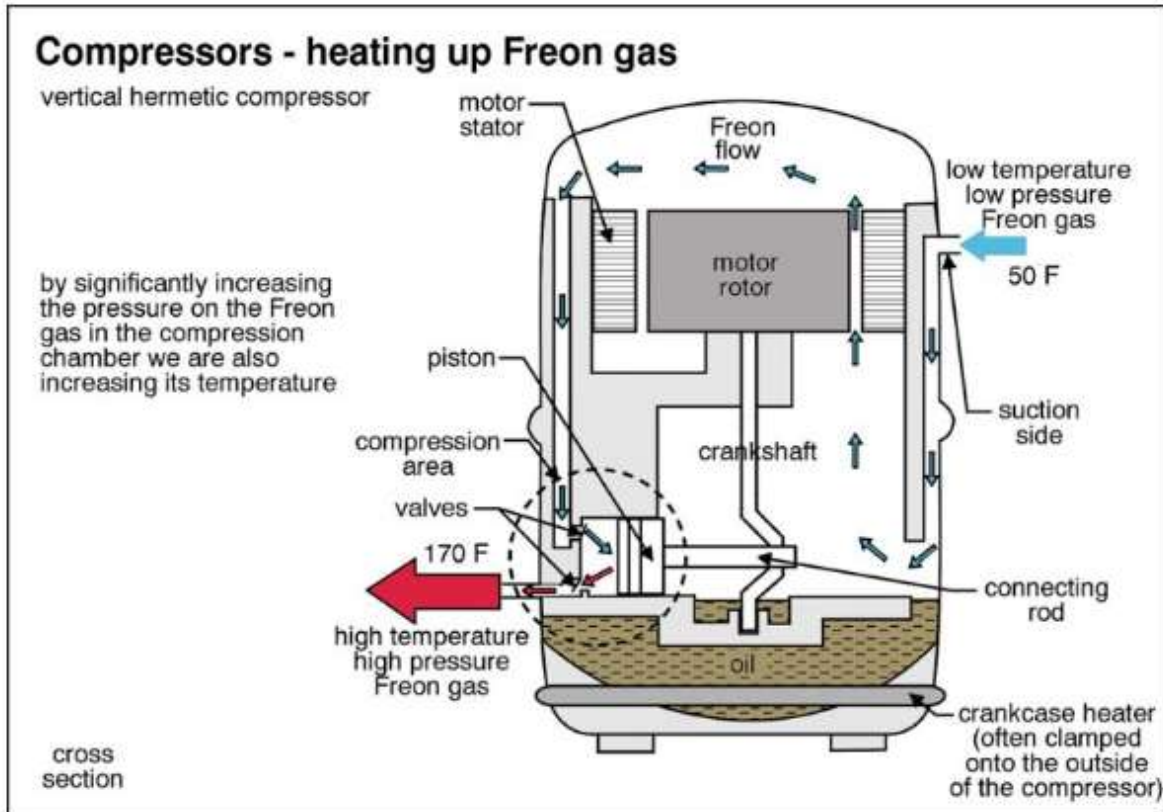

1.7 CONDENSER

- The purpose of the condenser is to receive the high-pressure gas from the compressor and convert this gas to a liquid.
- It does it by heat transfer, or the principle that heat will always move from a warmer to a cooler substance.
- Air passing over the condenser coils carries off the heat and the gas condenses.

The condenser often looks like an engine radiator.

- Condensers used on R-12 and R-134a systems are not interchangeable. Refrigerant-134a has a different molecular structure and requires a large capacity condenser.
- As the compressor subjects the gas to increased pressure, the heat intensity of the refrigerant is actually concentrated into a smaller area, thus raising the temperature of the refrigerant higher than the ambient temperature of the air passing over the condenser coils.
- Clogged condenser fins will result in poor condensing action and decreased efficiency. A factor often overlooked is flooding of the condenser coils with refrigerant oil. Flooding results from adding too much oil to the system.

- Oil flooding is indicated by poor condensing action, causing increased head pressure and high pressure on the low side. This will always cause poor cooling from the evaporator.

Expansion valve

- ★ The expansion valve removes pressure from the liquid refrigerant to allow expansion or change of state from a liquid to a vapour in the evaporator.
- ★ The high-pressure liquid refrigerant entering the expansion valve is quite warm. This may be verified by feeling the liquid line at its connection to the expansion valve. The liquid refrigerant leaving the expansion valve is quite cold.
- ★ The orifice within the valve does not remove heat, but only reduces pressure. Heat molecules contained in the liquid refrigerant are thus allowed to spread as the refrigerant moves out of the orifice.
- ★ Under a greatly reduced pressure the liquid refrigerant is at its coldest as it leaves the expansion valve and enters the evaporator.
- ★ Pressures at the inlet and outlet of the expansion valve will closely approximate gauge pressures at the inlet and outlet of the compressor in most systems.
- ★ The similarity of pressures is caused by the closeness of the components to each other.
- ★ The slight variation in pressure readings of a very few pounds is due to resistance, causing a pressure drop in the lines and coils of the evaporator and condenser.

1.8 EVAPORATOR

- The evaporator works the opposite of the condenser; here refrigerant liquid is converted to gas, absorbing heat from the air in the compartment.
- When the liquid refrigerant reaches the evaporator its pressure has been reduced, dissipating its heat content and making it much cooler than the fan air flowing around it.
- This causes the refrigerant to absorb heat from the warm air and reach its low boiling point rapidly. The refrigerant then vaporizes, absorbing the maximum amount of heat.
- This heat is then carried by the refrigerant from the evaporator as a low-pressure gas through a hose or line to the low side of the compressor, where the whole refrigeration cycle is repeated.
- The evaporator removes heat from the area that is to be cooled. The desired temperature of cooling of the area will determine if refrigeration or air conditioning is desired. For example, food preservation generally requires low refrigeration temperatures, ranging from 40°F (4°C) to below 0°F (-18°C).
- A higher temperature is required for human comfort. A larger area is cooled, which requires that large volumes of air be passed through the evaporator coil for heat exchange.
- A blower becomes a necessary part of the evaporator in the air conditioning system.

- The blower fans must not only draw heat-laden air into the evaporator, but must also force this air over the evaporator fins and coils where it surrenders its heat to the refrigerant and then forces the cooled air out of the evaporator into the space being cooled.

1.9 REFRIGERANT CONTROL DEVICES (THERMOSTATIC EXPANSION VALVE)

- ★ Thermostatic Expansion Valve.—before discussing the thermostatic expansion valve, let's explain the term SUPERHEAT.
- ★ In an evaporator, as the gas vapor moves along the coils toward the suction line, the gas may absorb additional heat and its temperature rises.
- ★ The difference in degrees between the saturation temperature and the increased temperature of the gas is called superheat.
- ★ A thermostatic expansion valve (fig.) keeps a constant superheat in the refrigerant vapor leaving the coil.
- ★ The valve controls the liquid refrigerant, so the evaporator coils maintain the correct amount of refrigerant at all times.
- ★ The valve has a power element that is activated by a remote bulb located at the end of the evaporator coils.
- ★ The bulb senses the superheat at the suction line and adjusts the flow of refrigerant into the evaporator. As the superheat increases (suction line), the temperature, and therefore the pressure, in the remote bulb also increases.
- ★ This increased pressure, applied to the top of the diaphragm, forces it down along with the pin, which, in turn, opens the valve, admitting replacement refrigerant from the receiver to flow into the evaporator. This replacement has three effects. First, it provides additional liquid refrigerant to absorb heat from the evaporator.
- ★ Second, it applies higher pressure to the bottom of the diaphragm, forcing it upward, tending to close the valve. And third, it reduces the degree of superheat by forcing more refrigerant through the suction line.

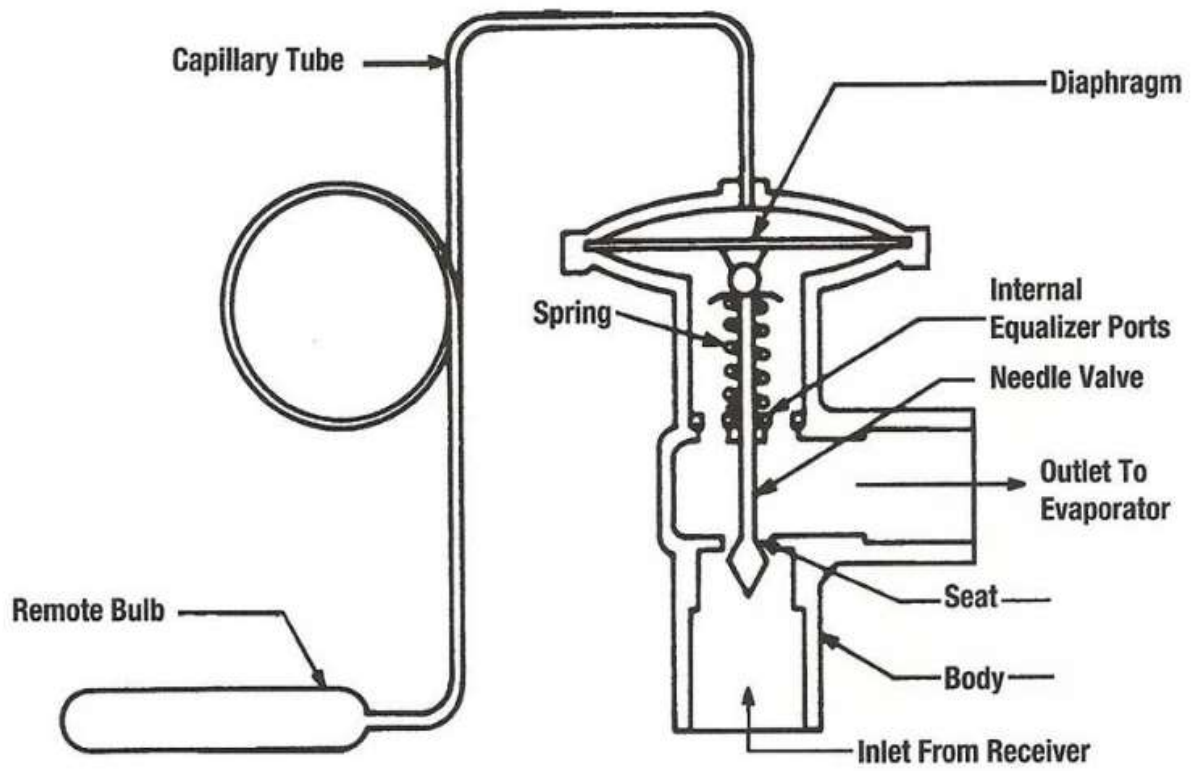

1.10 AIR HANDLING UNIT

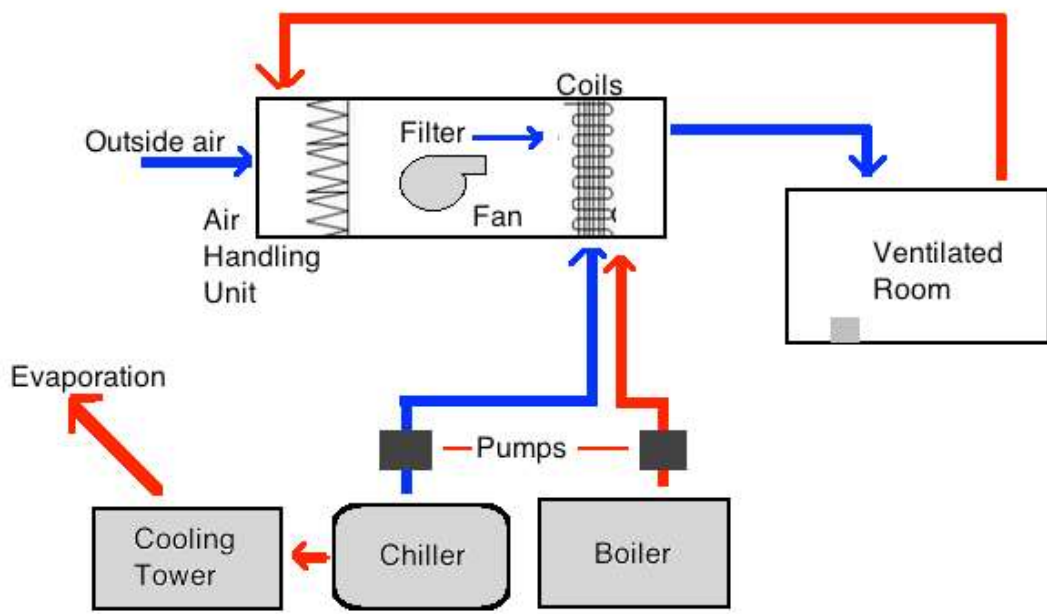

Fan

Centrifugal fan is used to circulate the air to the various parts of the sections in the building. The typical types of fan available are Backward Inclined, Backward Curved, Forward Curved and Airfoil.

The selection of the fan will depend on the air volume and the static pressure required of the system. Usually, the designer of the system will use a specialized software to do this selection.

In order to reduce the effect of vibration on the panel, the motor and the fan are usually installed on the vibration isolator except when the drive assembly is external to the fan casing.

In recent years, the use of variable air volume (VAV) system is becoming more popular as the volume of the air being discharged can be varied depending on the load condition. If the load is high, the fan speed will be higher and if the load is lower, the speed of the fan will be lower.

The speed of the fan is varied by using frequency inverter instead of conventional motor such as [PSC motor](#). Frequency inverter provides better control of the fan speed as a whole range of fan speed from super low to super high can now be utilized based on the load conditions required.

This technology has enabled better use of energy and is in tandem with the move to go for greener energy.

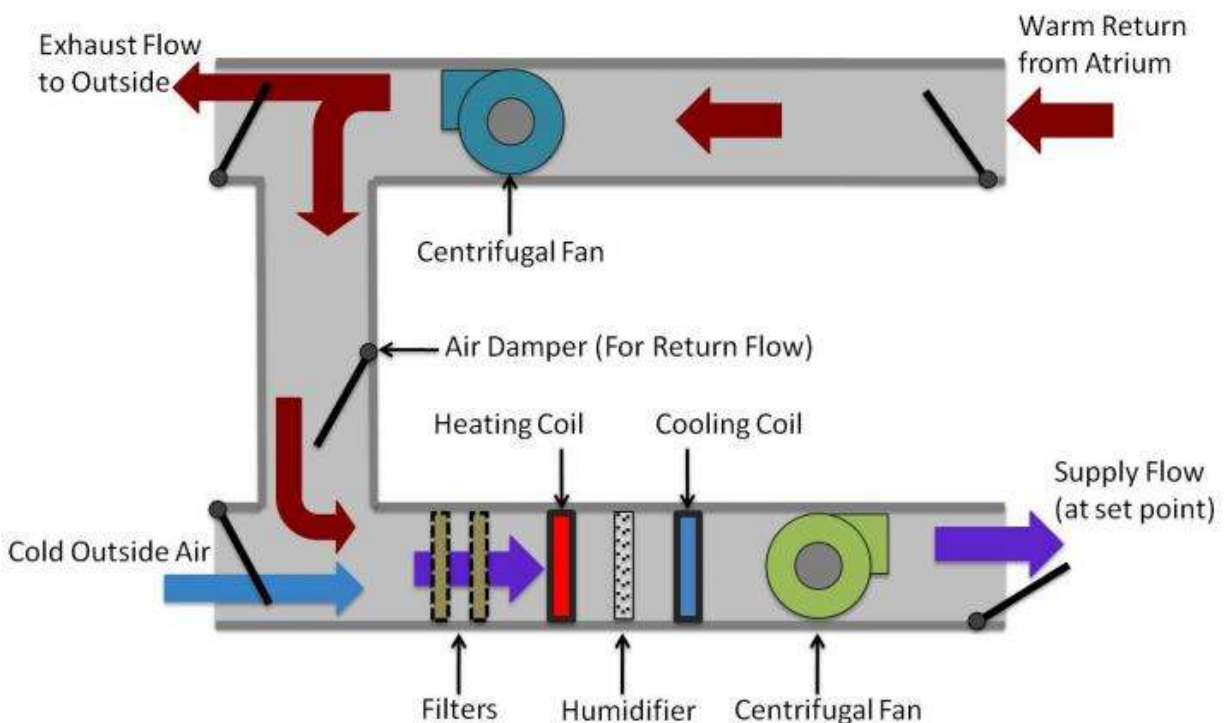

Cooling Coil

Cooling Coil is used to cool and dehumidify the air. Both DX (direct expansion) cooling and CW (chilled water) cooling coils are available for use depending on the system design.

These coils are arranged in rows with different fin spacing. Aluminium fins and copper tubes are used in the design of the coils. The corrosion resistance hydrophilic fins are also used due to its lower cost and lower resistance to the air velocity.

Filters

[Filters](#) are to remove particles and contaminants of various sizes from the air. The type of air filter being used will very much depend on the application of the system.

Panel Filter is a flat and rectangular in shape and provides a minimum low efficiency filtration which is acceptable to the air conditioning industry. The high velocity filter is arranged vertically whereas the low velocity filter is arranged in V shape. Typical air velocity that moves through the filters is in the range of 2-3 m/s.

HEPA Filter is very efficient and is able to achieve efficiencies up to 99.97%, removing minute particles and airborne bacteria from the air. It is usually used in clean room applications such as semiconductor production floor, operating theaters and critical processes.

Electrostatic Filter is used to remove particles from the air by using highly charged electrodes that ionized the air. Bag Filter is able to remove dust particles and is thrown away after use. Roll Filter is used for high velocity filtration where the used part is rolled up automatically/manually.

Humidifiers

During winter, the humidity level of the air can be low hence causing discomfort to the occupants. The humidity of the air is increased by using the humidifiers. Here are the commonly used [humidifiers](#):

Spray Type has a header and spray nozzles that spray water with a pressure of 15 psi or more.

Steam Pan Type has a pan and a heating coil to heat up the water of the pan. The evaporation of water caused by the heating will increase the humidity level of the surrounding air.

Steam Grid Type has tiny holes on the pipe to distribute the steam that flows through it. In this case, the water that is heated up to produce the steam to be supplied to the grid is conditioned to prevent odor being discharged to the room.

Mixing Box

This box has air inlets that is attached to the dampers. This is the place where the outside air and the return air are mixed to provide the correct proportion of air to be distributed to the space that is to be conditioned.

1.11 ELECTRIC MOTORS

Split-Phase AC Motor

This is the simplest design where the RUN winding and START winding are connected in parallel and 90° electrically apart. It is usually used in small pumps, fans and blowers where the capacity is below 1 horsepower. It has a low starting torque but high starting current. Since the torque is low, the ability to start the motor is only practical for low load condition.

The RUN winding is make from bigger diameter wire and shorter turn for lower resistance and high inductance properties. The START winding is make from smaller diameter wire for higher resistance and low inductance properties.

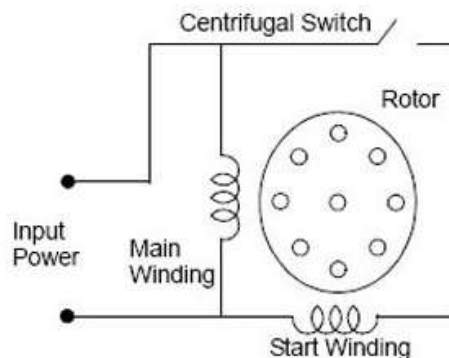

When power is connected to the motor, both the windings will be energized with the current in the RUN winding lags the current in the START winding by about 30° electrically. This out-of-phase effect on the stator produces a starting torque and causes the rotor to start rotating.

Typically the speed of the motor is 1800 rpm or 3600 rpm when running without any load. When the load is connected, the speed can go down to 1725 rpm and 3450 rpm respectively.

The no-load speed of the motor is given by:

$$\text{Speed(rpm)} = (\text{Frequency of AC power} \times 120) / \text{number of poles}$$

For example, if your supply is 60 Hz and the motor is using two-pole, the synchronous speed = $(60 \times 120) / 2$

= 3600 rpm

There is a switch known as centrifugal switch which is connected in series with the START winding. This mechanical switch will open when the motor speed reaches 75% of the rated speed typically within 2 seconds. Once the switch opened, the START winding in circuit is disconnected.

This is to protect the START winding from overheating. When the motor is powered off, the switch will close the circuit to get ready for the next starting of the motor.

These days, electronic relay is also being widely used to disconnect the START winding.

Single Phase Induction Motor

- ★ Single phase induction motor is an AC motor where electrical energy is converted to mechanical energy to perform some physical task. This induction motor requires only one power phase for their proper operation.
- ★ They are commonly used in low power applications, in domestic and industrial use. Simple construction, cheap cost, better reliability, easier to repair and better maintenance are some of its remarkable advantages.

Construction of Single Phase Induction Motor

- ★ The main components of the Single Phase induction motor are stator and rotor. Stator is known to be the stationary part.
- ★ Usually, the single phase alternating supply is given to the stator winding. Rotor is the rotating part of the motor. Rotor is connected to the mechanical load with the help of a shaft. A squirrel cage rotor is used here.
- ★ It has a laminated iron core with many slots. Rotor slots are closed or semi-closed type. The rotor windings are symmetrical and at the same time it is short circuited. An air gap is there between the rotor and the stator.
- ★ The most practical applications of this motor are in refrigerators, clocks, drills, pumps, washing machines etc. The stator winding in the 1 \emptyset induction motor has two parts: Main Winding and Auxiliary Winding.
- ★ Usually, the Auxiliary winding is perpendicular to the main winding. In 1 \emptyset induction motor the winding with more turns is known as main winding. While the other wire is called as auxiliary winding.

Principle of Operation

- ★ When the stator of a single phase motor is fed with single phase supply, it produces alternating flux in the stator winding. The alternating current flowing through stator winding causes induced current in the rotor bars (of the squirrel cage rotor) according to Faraday's law of electromagnetic induction. This induced current in the rotor will also produce alternating flux. Even after both alternating fluxes are set up, the motor fails to start. However, if the rotor is given an initial start by external force

in either direction, then motor accelerates to its final speed and keeps running with its rated speed.

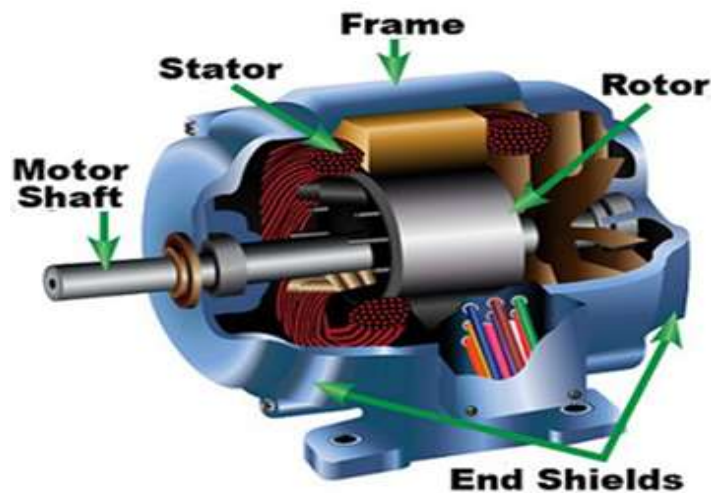

1.12 COOLING TOWERS

The purpose of a cooling tower is to cool down water that gets heated up by industrial equipment and processes. Water comes in the cooling tower hot (from industrial process) and goes out of the cooling tower cold.

The hot water is usually caused by air conditioning condensers or other industrial processes. That water is pumped through pipes directly into the cooling tower. Cooling tower nozzles are used to spray the water onto the “fill media”, which slows the water flow down and exposes the maximum amount of water surface area possible for the best air-water contact. The water is exposed to air as it flows throughout the cooling tower. The air is being pulled by a motor-driven electric “cooling tower fan”.

When the air and water come together, a small volume of water evaporates, creating an action of cooling. The colder water gets pumped back to the process/equipment that absorbs heat or the condenser. It repeats the loop over and over again to constantly cool down the heated equipment or condensers.

Cooling Tower Applications

Traditional HVAC heating and cooling systems are used in schools, large office buildings, and hospital. On the other hand, Cooling towers are much larger than traditional HVAC systems and are used to remove heat from cooling tower water systems in petroleum refineries, plants, natural gas processing plants, petrochemical plants, and other industrial processes.

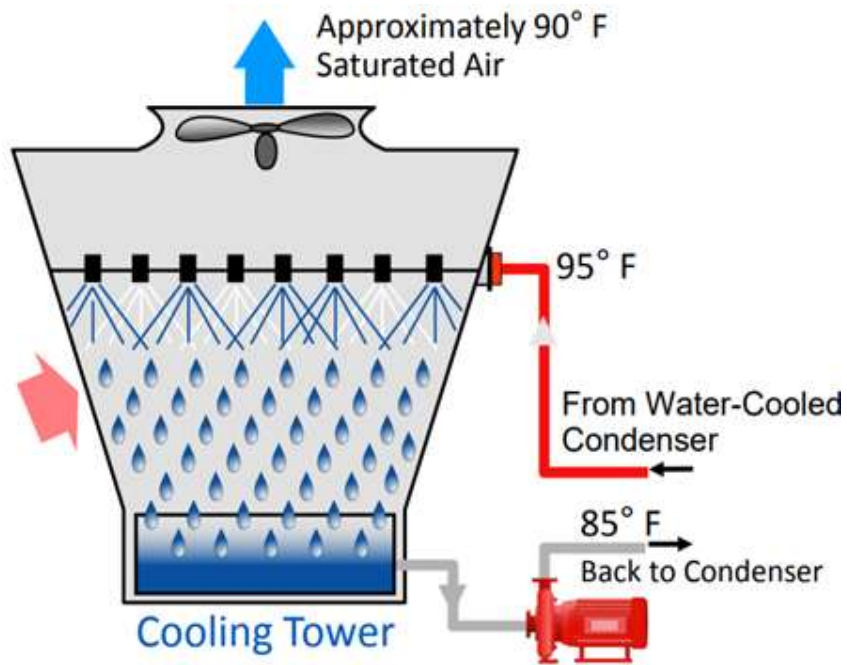
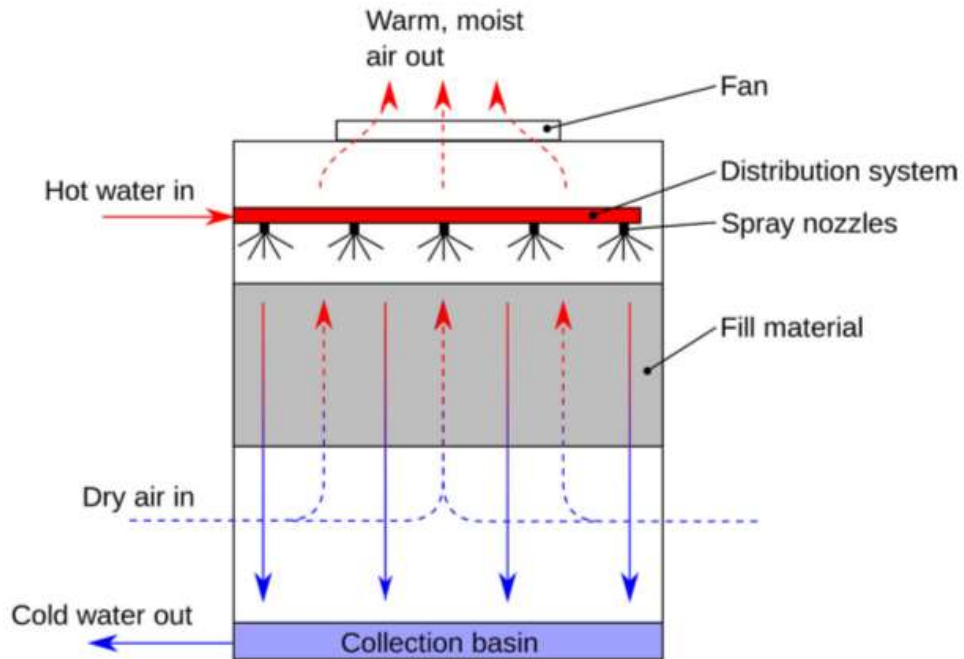

Most cooling towers work based on the principle of “evaporative cooling”.

Evaporative Cooling

Evaporative cooling is the process where warm water from an industrial process is pumped up to the top of the cooling tower where the water distribution system is. The water then gets distributed by cooling tower nozzles to the wet deck. At the same time, air

is being drawn through the air-inlet louvers forcing water to evaporate. Evaporation causes the heat to be removed from the makeup water.

Cross flow Cooling Towers Flow Diagram

In cross flow cooling tower systems the water vertically flows through the fill media while the air horizontally flows across the falling water. That's why they call it "cross flow" because the air and water cross paths or flows. Because of the crossing of flows, the air doesn't need to pass through the distribution system. This permits the use of hot water flow via gravity and distribution basins on the top of the tower right above the fill media. The basins are a standard of cross flow cooling towers and are applied on all units.

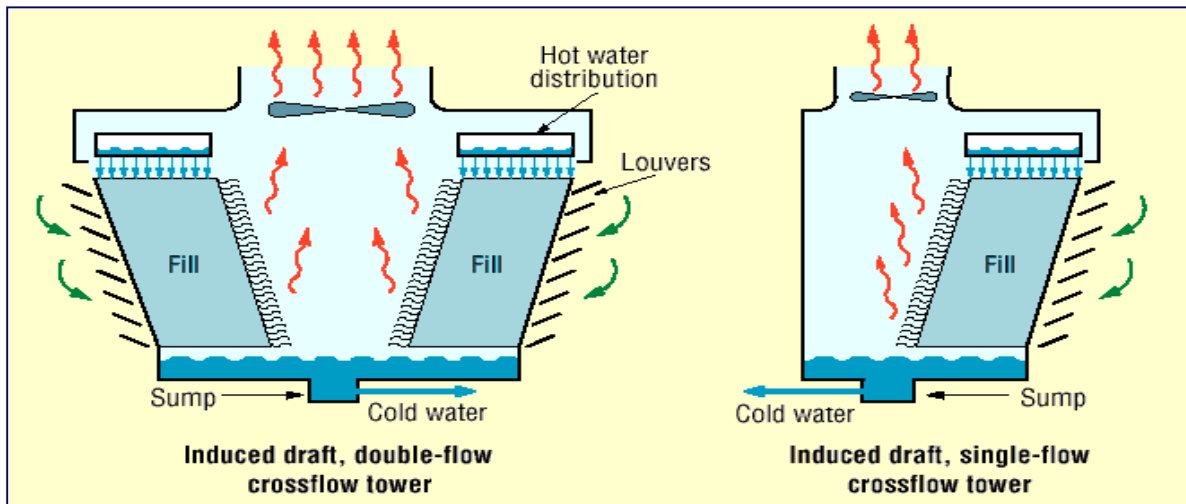

Counterflow Cooling Tower

In counter flow cooling tower system processes, the air vertically flows upwards, counter to the water flow in the fill media. Due to the air owing vertically, it's not possible to use the basin's gravity flow like in cross flow towers. As a substitute, these towers use pressurized spray systems, usually pipe-type, to spray the water on top of the fill media. The pipes and cooling tower nozzles are usually spread farther apart so they will not restrict any air flow.

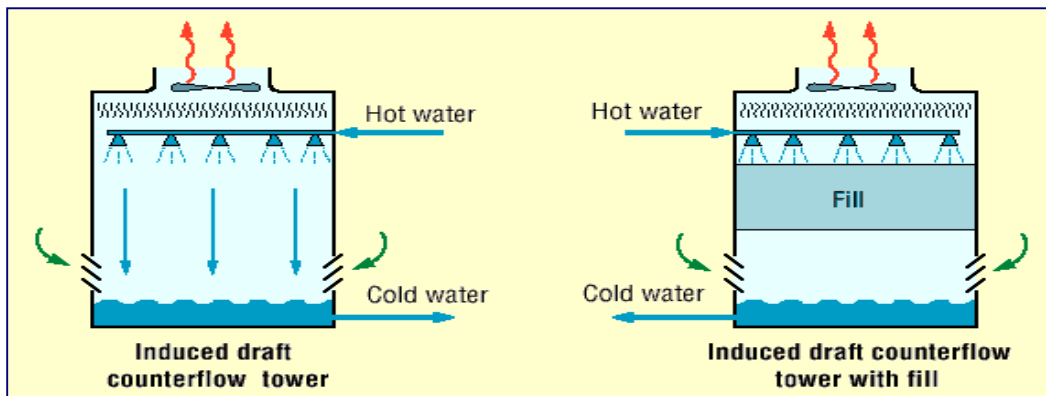

A.H.U. (AIR HANDLING UNIT)

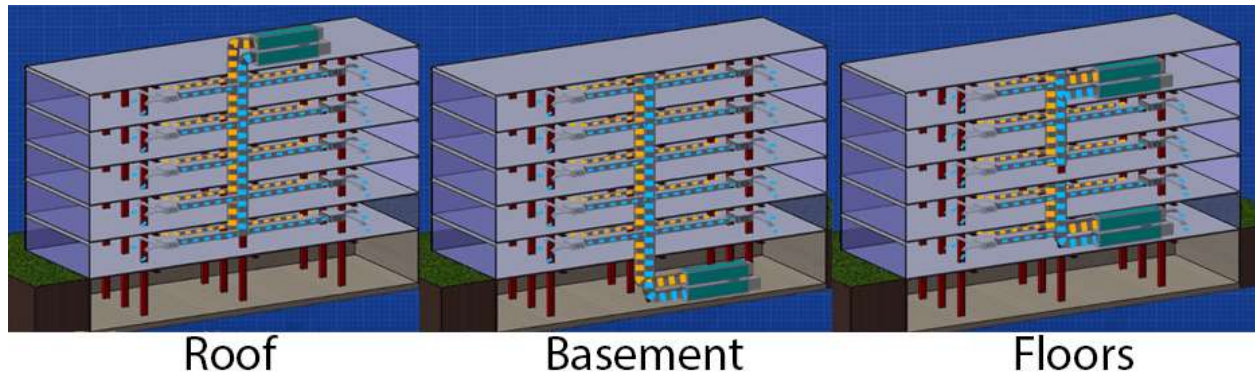

Air handling units, which usually have the acronym of A.H.U are found in medium to large commercial and industrial buildings.

They are usually located in the basement, on the roof or on the floors of a building. AHU's will serve a specified area or zone within a building such as the east side, or floors 1 - 10 or perhaps a single purpose such as just the buildings toilets. Therefore, it's very common to find multiple AHU's around a building.

Some buildings, particularly old high rise building, will have just one large AHU, usually located on the roof. These will supply the entire building. They might not have a return duct, some older designs rely on the air just leaking out of the building. This design isn't so common anymore in new buildings because it's very inefficient, now its most common to have multiple smaller AHU's supplying different zones. The buildings are also more air tight so we need to have a return duct to regulate the pressure inside the building.

So, what is the purpose of an air handling unit?

Air handling units' condition and distribute air within a building. They take fresh ambient air from outside, clean it, heat it or cool it, maybe humidify it and then force it through some ductwork around to the designed areas within a building. Most units will have an additional duct run to then pull the used dirty air out of the rooms, back to the AHU, where a fan will discharge it back to atmosphere. Some of this return air might be recirculated back into the fresh air supply to save energy, we'll have a look at that later in the article. Otherwise, where that isn't possible, thermal energy can extracted and fed into the fresh air intake. Again we'll look at that later in more detail.

DAMPERS

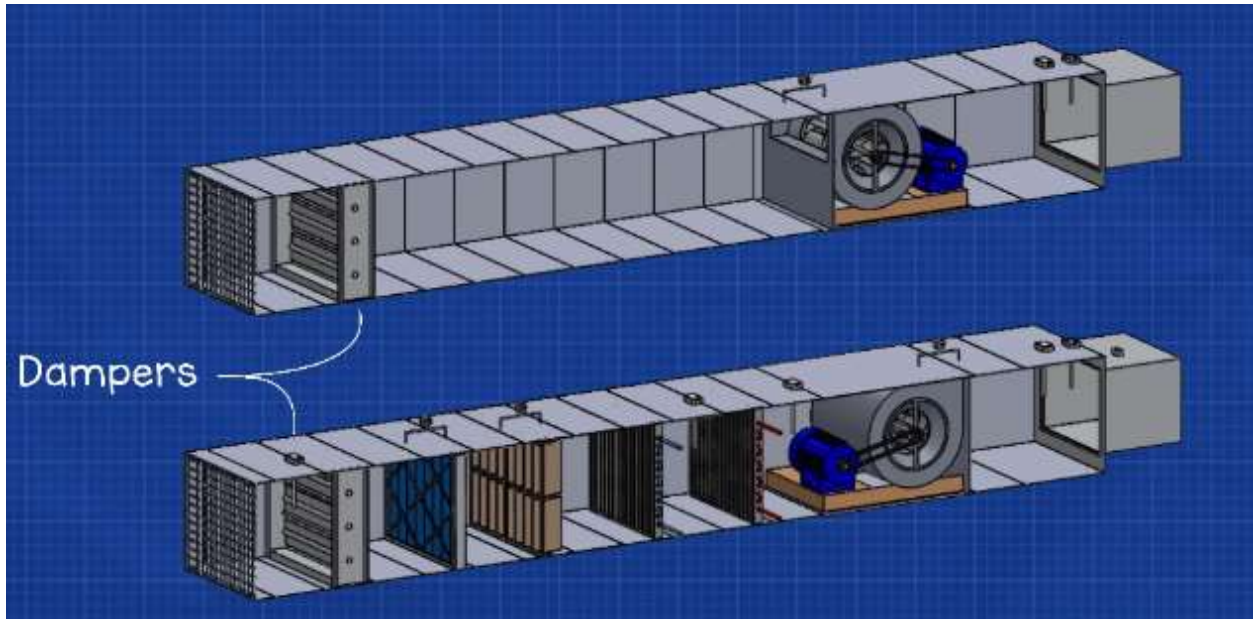

At the inlet of the fresh air housing and the discharge of the return air housing we have some dampers. The dampers are multiple sheets of metal which can rotate. They can close to prevent air from entering or exiting, they can open to fully allow air in or out, and it can also vary their position somewhere in between to restrict the amount of air that can enter or exit.

FILTERS

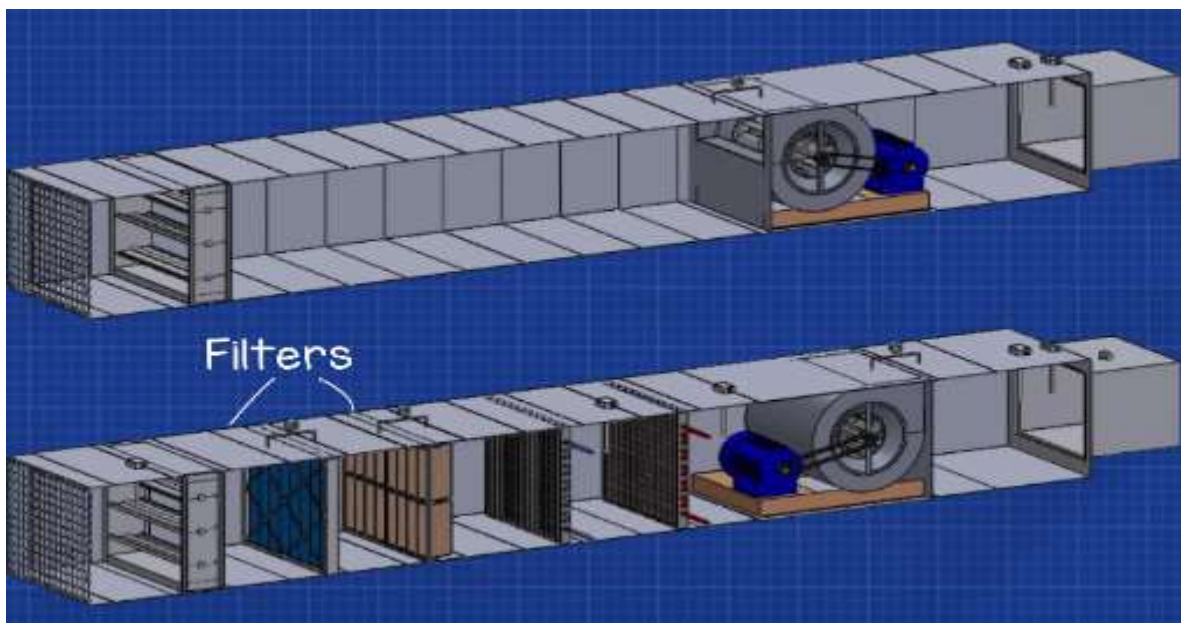

After the dampers we'll have some filters. These are there to try and catch all the dirt and dust etc from entering the ahu and the building. If we don't have these filters the dust is going to build up inside the ductwork and within the mechanical equipment, it's also going to enter the building and be breathed in by the occupants as well as make the building dirty. So, we want to remove as much of this as possible. Across each bank of filters, we'll have a pressure sensor. This will measure how dirty the filters are and warn the engineers when it's time to replace the filters. As the filters pickup dirt, the amount of air that can flow through is restricted and this causes a pressure drop across the filters. Typically, we have some panel filters or pre-filters to catch the largest dust particles. Then we have some bag filters to catch the smaller dust particles.

COOLING AND HEATING COILS

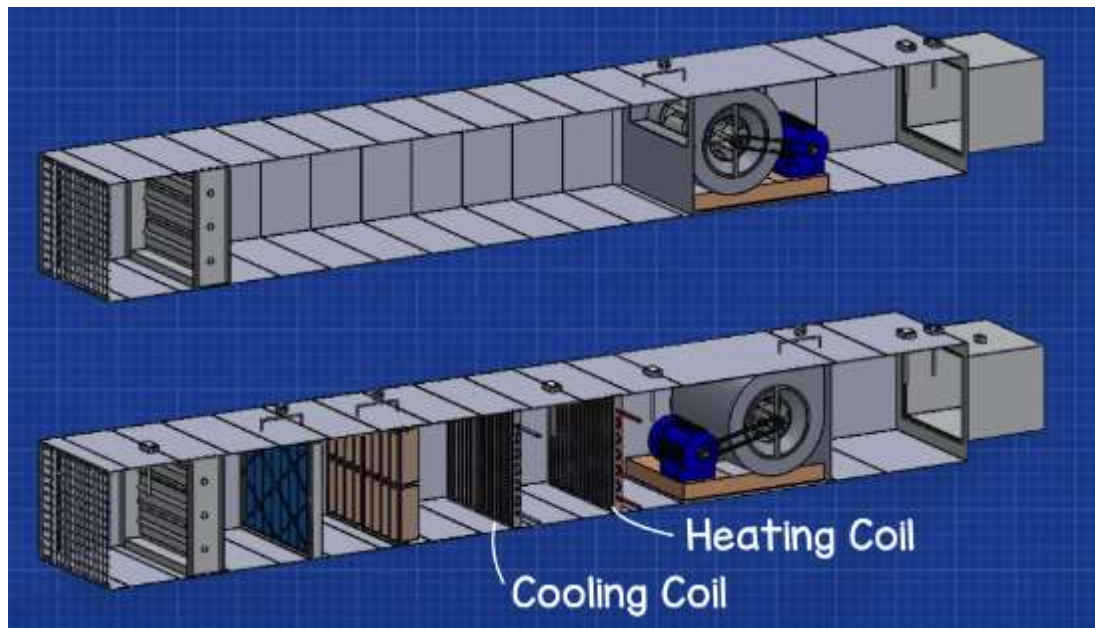

The next thing we'll find are the cooling and heating coils. These are there to heat or cool the air. The air temperature of the supply air is measured as it leaves the AHU and enters the ductwork. This needs to be at a designed temperature to keep the people inside the building comfortable, this designed temperature is called the set point temperature. If the air temperature is below this value the heating coil will add heat to increase the air temperature and bring it up to setpoint. If the air is too hot then the cooling coil will remove heat to lower the air temperature and reach the setpoint. The coils are heat exchangers, inside the coil is a hot or cold fluid, usually something like heated or chilled water, refrigerant or steam.

FAN

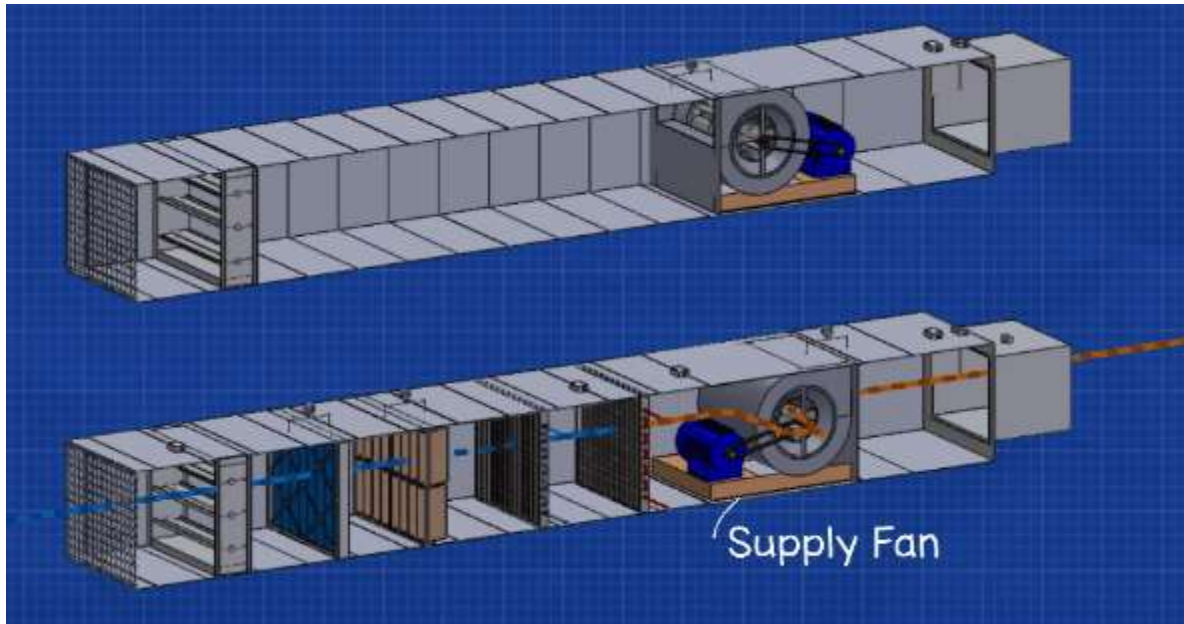

Next we'll have a fan. This is going to pull the air in from outside and then through the dampers, filters and coils and then push this out into the ductwork around the building. Centrifugal fans are very common in old and existing AHU's but EC fans are now being installed and also retro fitted for increased energy efficiency. Across the fan we'll also have a pressure sensor, this will sense if the fan is running. If it is running then it will create a pressure difference, we can use this to detect a failure in the equipment and warn the engineers of the problem. We'll also likely have a duct pressure sensor shortly after the fan, this will read the static pressure and in some ahu's the speed of the fan is controlled as a result of the pressure in the duct, so we'll also very often find a variable speed drive connected to the fan for variable volume systems.

Then we have the ductwork which will send the air around the building to the designed areas. We'll also have some ductwork coming back which is bringing all the used air from the building back to a separate part of the AHU. This return AHU is usually located near the supply, but it doesn't have to be, it can be located elsewhere.

The return AHU in its simplest form has just a fan and damper inside. The fan is pulling the air in from around the building and then pushing it out of the building. The damper is located at the exit of the AHU housing and will close when the AHU turns off.

HUMIDIFIER

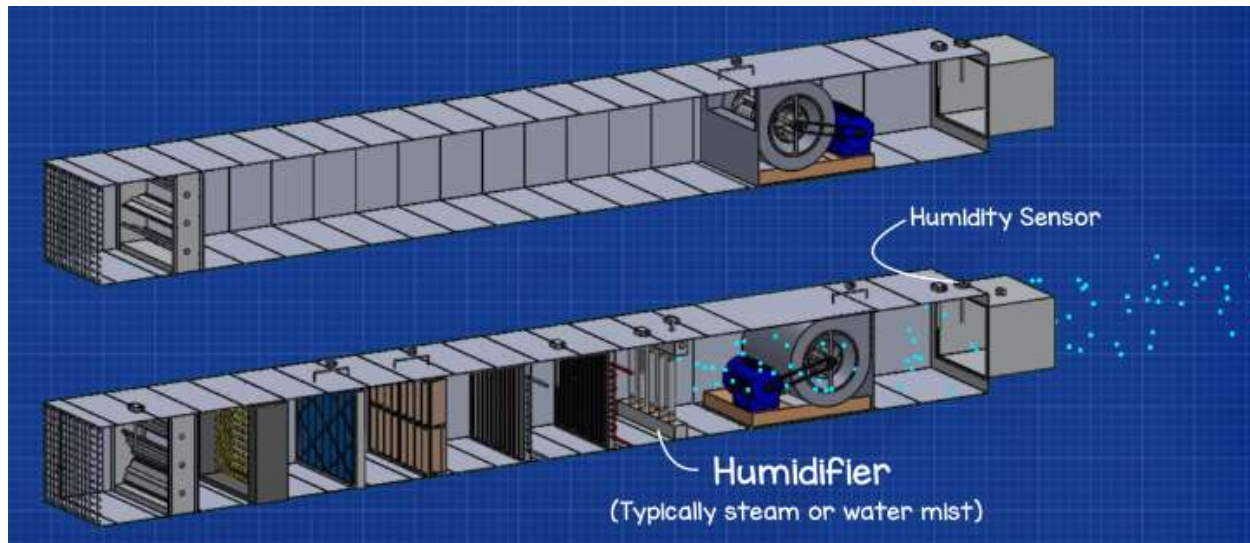

Some buildings need to control the humidity of the air they supply into the building. We'll find a humidity sensor at the outlet of the supply AHU to measure the moisture in the supply air, this will also have a setpoint for how much moisture should be in the air by design.

If the air's moisture content is below this value then we need to introduce moisture into the air using a humidifier, this is usually one of the last things in the AHU. This device will usually either add steam or spray a water mist into the air. Many standard office type buildings in northern Europe and north America have turned off their humidity units or uninstalled them to save energy. Although they're still crucial for places like document stores and computer rooms.

If the air is too humid then this can be reduced through the cooling coil. As the air hits the cooling coil the cold surface will cause the moisture within the air to condense and flow away, you'll find a drain pan under the cooling coil to catch the water and drain this away. The cooling coil can be used to further reduce the moisture content by removing more heat, but of course this will decrease the air temperature below the supply setpoint, if this occurs then the heating coil can also be turned on to bring the temperature back up, this will work although it is very energy intensive.



Another very common version we'll come across is to have a duct sit in between the exhaust and the fresh air intake. This allows some of the exhaust air to be recirculated back into the fresh air intake, to offset the heating or cooling demand. This is safe and healthy to do but you will need to ensure the exhaust air has a low Co₂ count so we need some Co₂ sensors to monitor that. If the Co₂ level is too high then the air can't be re-used, the mixing damper will close and the all the return air will be rejected from the building. When in recirculation mode, the main inlet and outlet dampers will not fully close in this setup because we still need a minimum amount of fresh air to enter the building. We can use this in winter if the return air is warmer than the outside air and we can use this in summer if the return air is cooler than the outside air, respective to the supply setpoint air temperature, so we'll also need some temperature sensors at the intake, return and just after the mixing region. Some buildings require 100% fresh air so this strategy can't be used everywhere, local laws and regulations will dictate this.

1.13 Air conditioning systems for buildings of different scales and their requirements

Criteria	Central system	Decentralized system
Temperature, humidity, and space pressure requirements	Fulfilling any or all of the design parameters	Fulfilling any or all of the design parameters
Capacity requirements	<ul style="list-style-type: none"> ■ Considering HVAC diversity factors to reduce the installed equipment capacity ■ Significant first cost and operating cost 	<ul style="list-style-type: none"> ■ Maximum capacity is required for each equipment ■ Equipment sizing diversity is limited
Redundancy	Standby equipment is accommodated for troubleshooting and maintenance	No backup or standby equipment
Special requirements	<ul style="list-style-type: none"> ■ An equipment room is located outside the conditioned area, or adjacent to or remote from the building ■ Installing secondary equipment for the air and water distribution which requires additional cost 	<ul style="list-style-type: none"> ■ Possible of no equipment room is needed ■ Equipment may be located on the roof and the ground adjacent to the building

First cost	<ul style="list-style-type: none"> ■ High capital cost ■ Considering longer equipment services life to compensate the high capital cost 	<ul style="list-style-type: none"> ■ Affordable capital cost
Operating cost	<ul style="list-style-type: none"> ■ More significant energy efficient primary equipment ■ A proposed operating system which saves operating cost 	<ul style="list-style-type: none"> ■ Less energy efficient primary equipment ■ Various energy peaks due to occupants' preference ■ Higher operating cost
Maintenance cost	Accessible to the equipment room for maintenance and saving equipment in excellent condition, which saves maintenance cost	Accessible to equipment to be located in the basement or the living space. However, it is difficult for roof location due to bad weather
Reliability	Central system equipment can be an attractive benefit when considering its long service life	Reliable equipment, although the estimated equipment service life may be less
Flexibility	Selecting standby equipment to provide an alternative source of HVAC or backup	Placed in numerous locations to be more flexible

AIR CONDITIONING SYSTEM FOR SMALL BUILDINGS

The choice of which air conditioner system to use depends upon a number of factors including how large the area is to be cooled, the total heat generated inside the enclosed area, etc. An HVAC designer would consider all the related parameters and suggest the system most suitable for your space.

1.14 WINDOW AIR CONDITIONER

- ★ Window air conditioner is the most commonly used air conditioner for single rooms. In this air conditioner all the components, namely the compressor, condenser, expansion valve or coil, evaporator and cooling coil are enclosed in a single box.
- ★ This unit is fitted in a slot made in the wall of the room, or more commonly a window sill.
- ★ Window air conditioners are one of the most popular types of air conditioners being used. Whether it's your study room, bedroom, or hall, the window air conditioner can be used for almost all types of spaces.
- ★ To fit the window air conditioner in your room, you need to make a slot in one of the walls of the room that is to be cooled.
- ★ This system extends around two feet beyond the wall in the back side; hence behind the wall some free space should be available so that the hot air can be thrown easily from the condenser.
- ★ The dew collected from the room is also thrown from the back of the air conditioner. Thus window air conditioners can be used only if there is place available in the wall to make the slot, and there is free space behind the wall for dissipating the heat and dripping water.
- ★ Window air conditioners are comprised of components like the compressor, condenser, expansion valve or expansion coil, and the evaporator or the cooling coil, all housed in a single box.
- ★ There is also a motor which has shafts on both sides. On one side of the shaft the blower is connected, which sucks hot air from the room and blows it over the cooling coil, thus cooling it and sending it to the room.
- ★ On the other shaft the fan is connected, which blows the air over Freon gas passing through the condenser.
- ★ The window air conditioner is the cheapest of all air conditioning systems. If your room or office size is about less than 100 sq. ft. a window air conditioner of about 0.8 ton can be good enough.
- ★ If the size of room is more than this but less than 200 sq. ft. your HVAC designer will recommend a window air conditioner of about 1 ton. For rooms of bigger sizes but less than 300 sq. ft. the system of about 1.5 ton is advisable.
- ★ However, these sizes may change depending upon the number of people occupying the space, its alignment with respect to sun, and other sources of heat generation inside the room.
- ★ It is better to consult your HVAC designer to find out the exact size of window air conditioner suitable for your space.

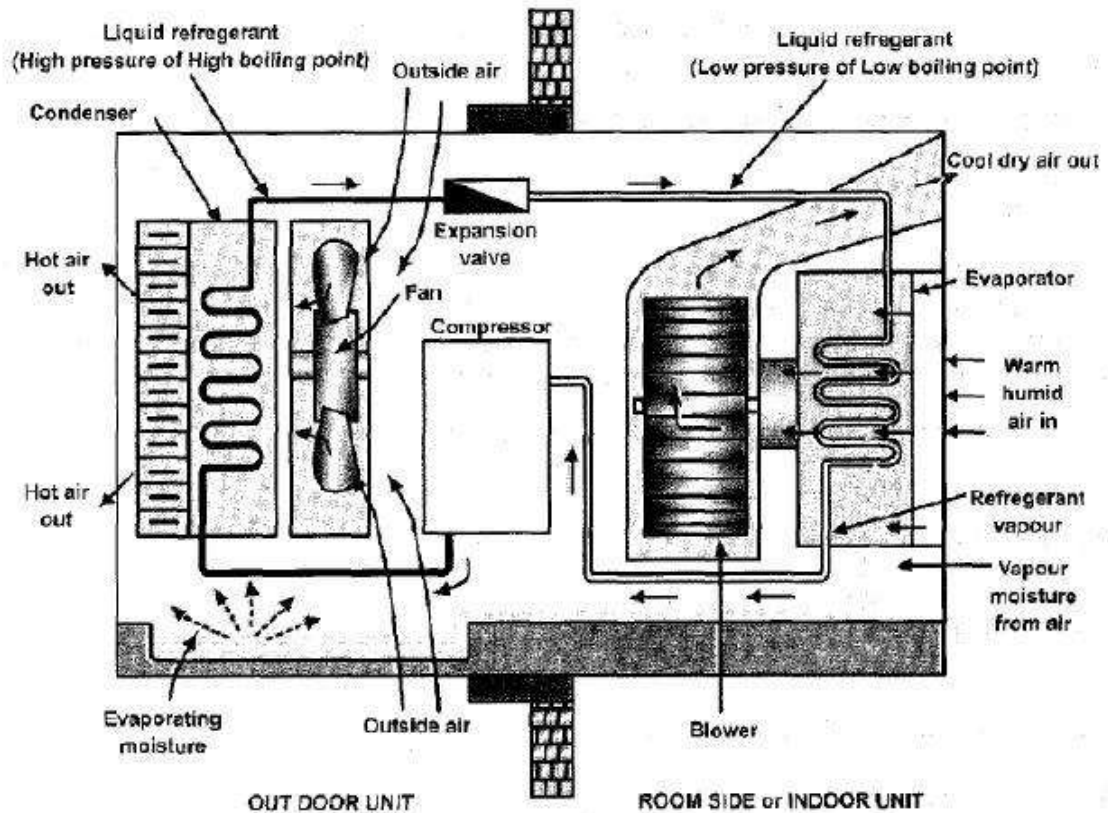

- ★ One of the complaints that window air conditioners have had is that they tend to make noise inside the room. But this problem has been greatly overcome by the present day efficient and less noisy rotary compressors, which also consume less electricity.
- ★ Today a number of fancy and elegant looking models of window air conditioners are available that enhance the beauty of your rooms.
- ★ Split air conditioners are used for small rooms and halls, usually in places where window air conditioners cannot be installed. However, these days many people prefer split air conditioner units even for places where window air conditioners can be fitted.

EVAPORATIVE COOLER

As the name indicates, evaporative cooling is the process of reducing the temperature of a system by evaporation of water. Human beings perspire and dissipate their metabolic heat by evaporative cooling if the ambient temperature is more than skin temperature. Animals such as the hippopotamus and buffalo coat themselves with mud for evaporative cooling.

Direct evaporative cooling (open circuit) is used to lower the temperature of air by using latent heat of evaporation, changing liquid water to water vapor. In this process,

the energy in the air does not change. Warm dry air is changed to cool moist air. The heat of the outside air is used to evaporate water.

Indirect evaporative cooling (closed circuit) is similar to direct evaporative cooling, but uses some type of heat exchanger. The cooled moist air never comes in direct contact with the conditioned environment.

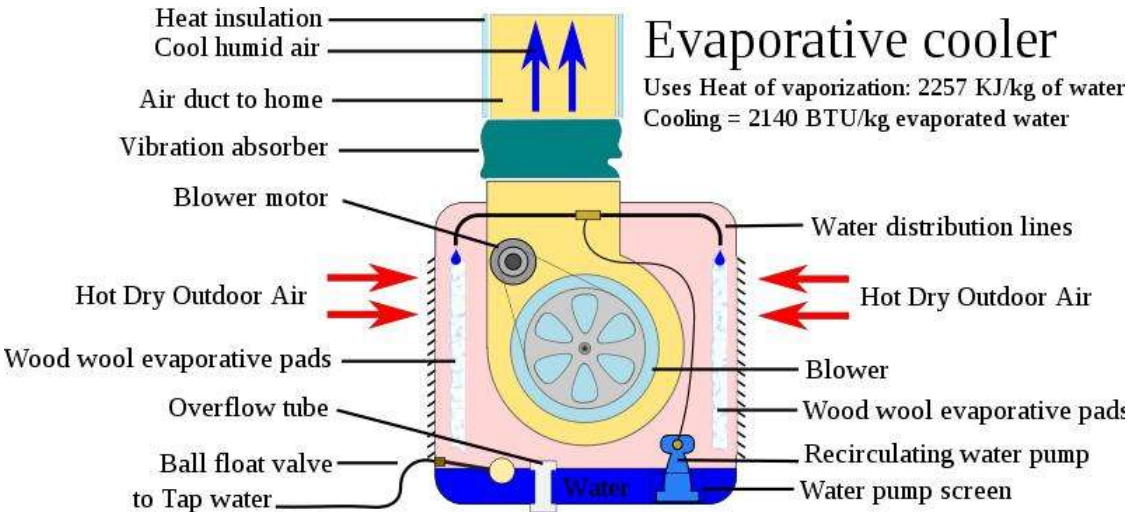

Advantages and disadvantages of evaporative cooling systems:

Compared to the conventional refrigeration based air conditioning systems, the evaporative cooling systems offer the following **advantages**:

- Lower equipment and installation costs
- Substantially lower operating and power costs. Energy savings can be as high as 75%
- Ease of fabrication and installation
- Lower maintenance costs
- Ensures a very good ventilation due to the large air flow rates involved, hence, are very good especially in 100 % outdoor air applications
- Better air distribution in the conditioned space due to higher flow rates
- The fans/blowers create positive pressures in the conditioned space, so that infiltration of outside air is prevented
- Very environment friendly as no harmful chemicals are used

Compared to the conventional systems, the evaporative cooling systems suffer from the following **disadvantages**:

- ✓ The moisture level in the conditioned space could be higher, hence, direct evaporative coolers are not good when low humidity levels in the conditioned space is required. However, the indirect evaporative cooler can be used without increasing humidity
- ✓ Since the required air flow rates are much larger, this may create draft and/or high noise levels in the conditioned space

- ✓ Precise control of temperature and humidity in the conditioned space is not possible
- ✓ May lead to health problems due to micro-organisms if the water used is not clean or the wetted surfaces are not maintained properly.

1.15 PACKAGED AIR CONDITIONERS

- The window and split air conditioners are usually used for the small air conditioning capacities up to 5 tons.
- The central air conditioning systems are used for where the cooling loads extend beyond 20 tons.
- The packaged air conditioners are used for the cooling capacities in between these two extremes. The packaged air conditioners are available in the fixed rated capacities of 3, 5, 7, 10 and 15 tons.
- These units are used commonly in places like restaurants, telephone exchanges, homes, small halls, etc.
- As the name implies, in the packaged air conditioners all the important components of the air conditioners are enclosed in a single casing like window AC.
- Thus the compressor, cooling coil, air handling unit and the air filter are all housed in a single casing and assembled at the factory location.

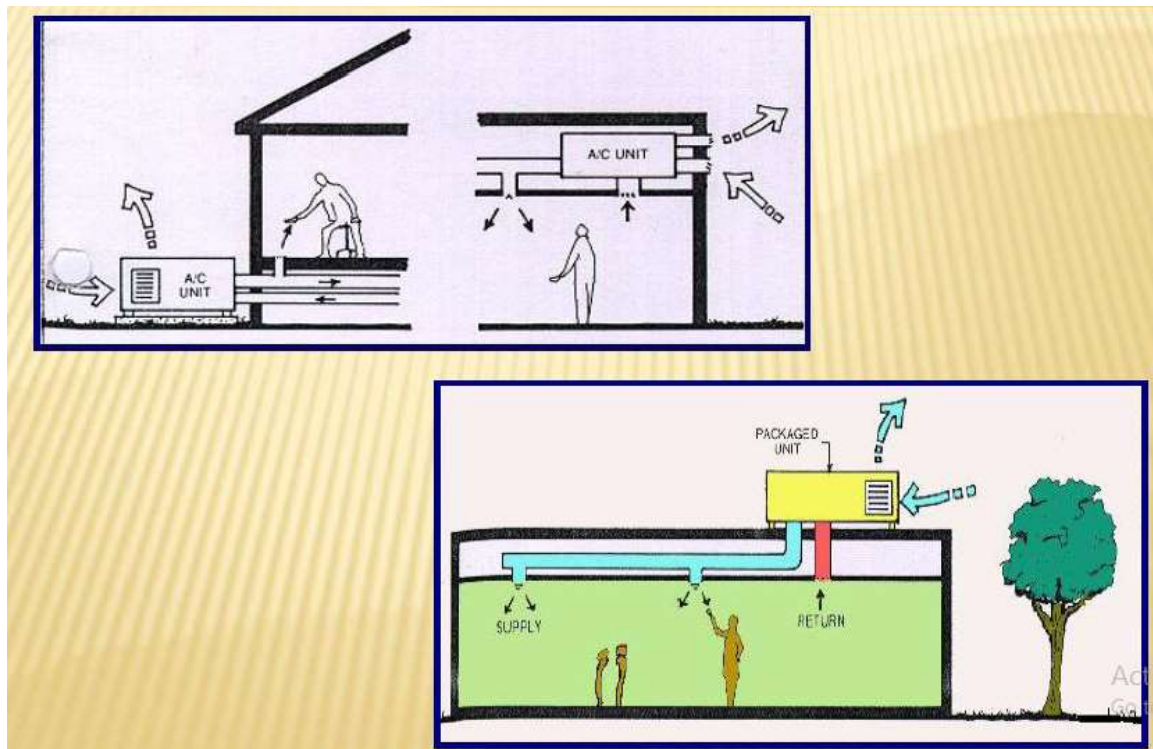

- Depending on the type of the cooling system used in these systems, the packaged air conditioners are divided into two types:
 - 1) one with water cooled condenser and
 - 2) one with air cooled condensers.

Both these systems have been described below:

Packaged Air Conditioners with Water Cooled Condenser

- ★ In these packaged air conditions the condenser is cooled by the water. The condenser is of shell and tube type, with refrigerant flowing along the tube side and the cooling water flowing along the shell side.
- ★ The water has to be supplied continuously in these systems to maintain functioning of the air conditioning system.
- ★ The shell and tube type of condenser is compact in shape and it is enclosed in a single casing along with the compressor, expansion valve, and the air handling unit including the cooling coil or the evaporator.
- ★ This whole packaged air conditioning unit externally looks like a box with the control panel located externally.

1.16 SPLIT AIR CONDITIONER

The **split air conditioner** comprises of two parts: the outdoor unit and the indoor unit. The outdoor unit, fitted outside the room, houses components like the compressor, condenser and expansion valve. The indoor unit comprises the evaporator or cooling coil and the cooling fan. For this unit you don't have to make any slot in the wall of the room. Further, present day split units have aesthetic appeal and do not take up as much space as a window unit. A split air conditioner can be used to cool one or two rooms.

There are two main parts of the split air conditioner. These are:

- 1) **Outdoor unit:** This unit houses important components of the air conditioner like the compressor, condenser coil and also the expansion coil or capillary tubing. This unit is installed outside the room or office space which is to be cooled. The compressor is the maximum noise making part of the air conditioner, and since in the split air conditioner, it is located outside the room, the major source of noise is eliminated. In the outdoor unit there is a fan that blows air over the condenser thus cooling the compressed Freon gas in it. This gas passes through the expansion coil and gets converted into low pressure, low temperature partial gas and partial liquid Freon fluid.

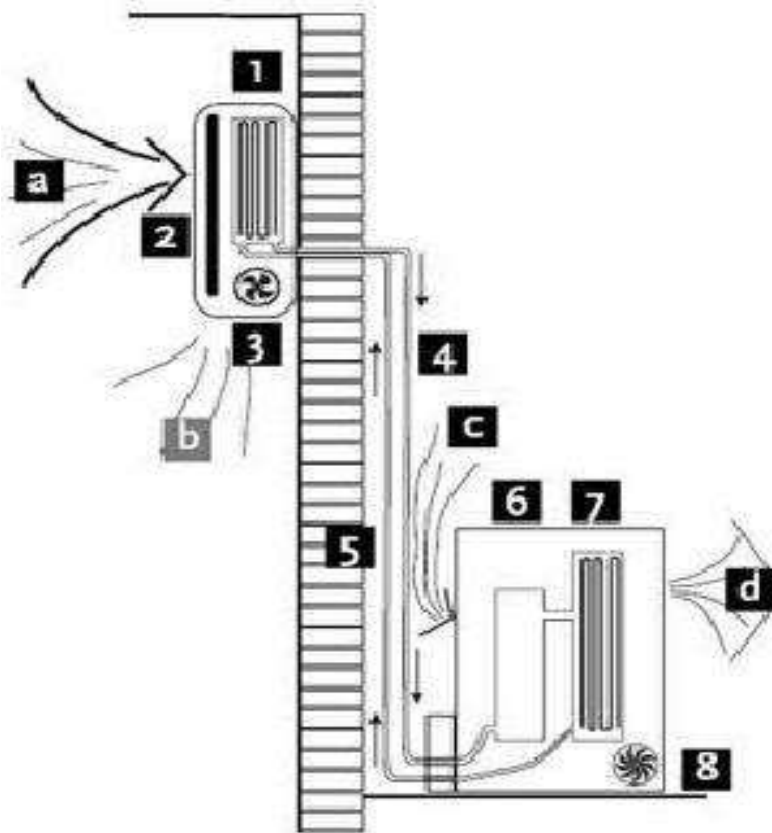
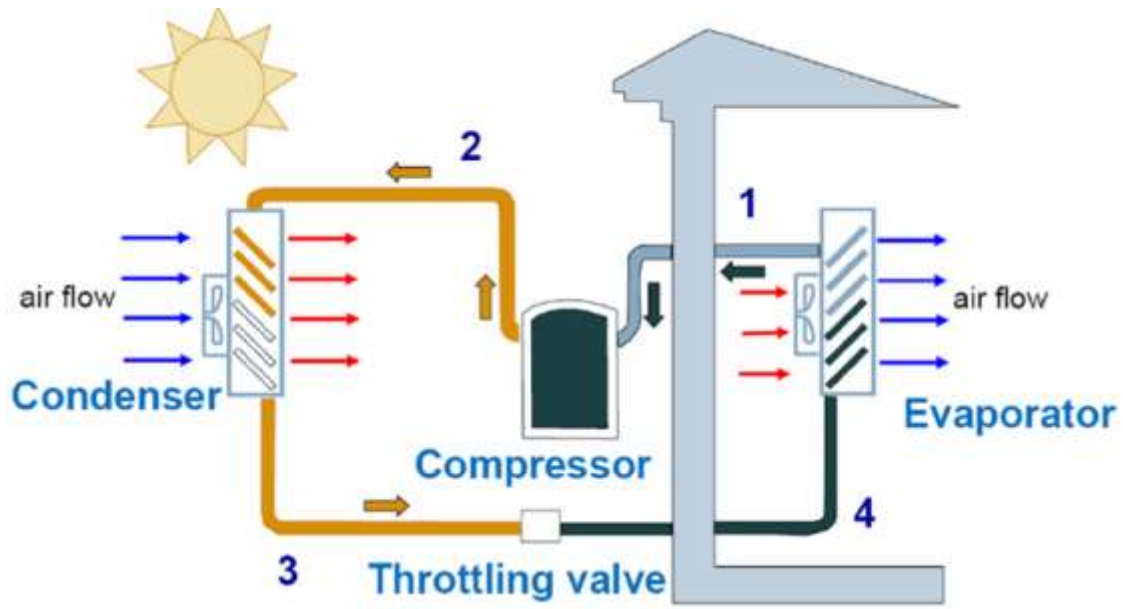

- | | |
|---------------|----------------|
| 1. Evaporator | 5. Liquid line |
| 2. Filter | 6. Compressor |
| 3. Fan | 7. Condenser |
| 4. Gas line | 8. Fan |

2) Indoor unit:

- ★ It is the indoor unit that produces the cooling effect inside the room or the office. This is a beautiful looking tall unit usually white in color, though these days a number of stylish models of the indoor unit are being launched.
- ★ The indoor unit houses the evaporator coil or the cooling coil, a long blower and the filter. After passing from the expansion coil, the chilled Freon fluid enters the cooling coil.
- ★ The blower sucks the hot, humid and filtered air from the room and it blows it over the cooling coil. As the air passes over cooling coil its temperature reduces drastically and also loses the excess moisture.
- ★ The cool and dry air enters the room and maintains comfortable conditions of around 25-27 degree Celsius as per the requirements.
- ★ The temperature inside the space can be maintained by thermostat setting. The setting should be such that comfortable conditions are maintained inside the room, and there is also chance for the compressor to trip at regular intervals. If the compressor keeps running continuously without break, its life will reduce.
- ★ These days multi-split air conditioners are also being used commonly. In units for one outdoor unit there are two indoor units which can be placed in two different rooms or at two different locations inside a large room.
- ★ Since there is long distance between the indoor and the outdoor unit, there is always loss of some cooling effect; hence for the same tonnage, split air conditioners produce somewhat less cooling effect than window air conditioners.
- ★ However, with modern insulation material this gap has been reducing between the two. In any case, there are number of instances where there is just no alternative to the split air conditioners.

CENTRALIZED AIR CONDITIONING

- ★ Central air conditioning plants are used for applications like big hotels, large buildings having multiple floors, hospitals, etc, where very high cooling loads are required.
- ★ The article describes various possible arrangements of central air conditioning plants.
- ★ The central air conditioning plants or the systems are used when large buildings, hotels, theaters, airports, shopping malls etc are to be air conditioned completely.
- ★ The window and split air conditioners are used for single rooms or small office spaces. If the whole building is to be cooled it is not economically viable to put window or split air conditioner in each and every room.
- ★ Further, these small units cannot satisfactorily cool the large halls, auditoriums, receptions areas etc.
- ★ In the central air conditioning systems there is a plant room where large compressor, condenser, thermostatic expansion valve and the evaporator are kept in the large plant room.

- ★ They perform all the functions as usual similar to a typical refrigeration system. However, all these parts are larger in size and have higher capacities.
- ★ The compressor is of open reciprocating type with multiple cylinders and is cooled by the water just like the automobile engine. The compressor and the condenser are of shell and tube type.
- ★ While in the small air conditioning system capillary is used as the expansion valve, in the central air conditioning systems thermostatic expansion valve is used.
- ★ The chilled air is passed via the ducts to all the rooms, halls and other spaces that are to be air conditioned.
- ★ Thus in all the rooms there is only the duct passing the chilled air and there are no individual cooling coils, and other parts of the refrigeration system in the rooms. What is we get in each room is the completely silent and highly effective air conditions system in the room.

Further, the amount of chilled air that is needed in the room can be controlled by the openings depending on the total heat load inside the room.

The central air conditioning systems are highly sophisticated applications of the air conditioning systems and many a times they tend to be complicated. It is due to this reason that there are very few companies in the world that specialize in these systems. In the modern era of computerization a number of additional electronic utilities have been added to the central conditioning systems.

- i. **Direct expansion or DX central air conditioning plant:** In this system the huge compressor, and the condenser are housed in the plant room, while the expansion valve and the evaporator or the cooling coil and the air handling unit are housed in separate room. The cooling coil is fixed in the air handling unit, which also has large blower housed in it. The blower sucks the hot return air from the room via ducts and blows it over the cooling coil. The cooled air is then supplied through various ducts and into the spaces which are to be cooled. This type of system is useful for small buildings.
- ii. **Chilled water central air conditioning plant:** This type of system is more useful for large buildings comprising of a number of floors. It has the plant room where all the important units like the compressor, condenser, throttling valve and the evaporator are housed. The evaporator is a shell and tube. On the tube side the Freon fluid passes at extremely low temperature, while on the shell side the brine solution is passed. After passing through the evaporator, the brine solution gets chilled and is pumped to the various air handling units installed at different floors of the building. The air handling units comprise the cooling coil through which the chilled brine flows, and the blower. The blower sucks hot return air from the room via ducts and blows it over the cooling coil. The cool air is then supplied to the space to be cooled through the ducts. The brine solution which has absorbed the room heat comes back to the evaporator, gets chilled and is again pumped back to the air handling unit.

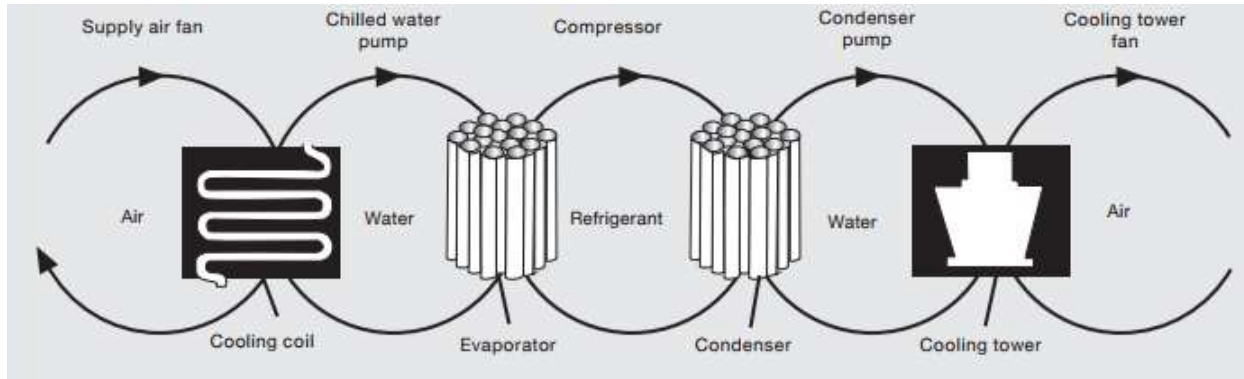

Introduction

- ★ There are two types of central air conditioning systems: Direct Expansion (DX) type of central air condition plants and Chilled Water type of the central air conditioning plants.
- ★ In the DX system the air used for cooling the room or space is directly passed over the cooling coil of the refrigeration plant. In case of the chilled water system the refrigeration system is used to first chill the water, which is then used to chill the air used for cooling the rooms or spaces.

Both these systems have been discussed in details; this article discusses DX system, while the next one describes chilled water system.

1.17 DIRECT EXPANSION (DX) TYPE OF CENTRAL AIR CONDITIONING PLANT

- In the direct expansion or DX types of air central conditioning plants the air used for cooling space is directly chilled by the refrigerant in the cooling coil of the air handling unit.
- Since the air is cooled directly by the refrigerant the cooling efficiency of the DX plants is higher.
- However, it is not always feasible to carry the refrigerant piping to the large distances hence, direct expansion or the DX type of central air conditioning system is usually used for cooling the small buildings or the rooms on the single floor.

There are three main compartments of the DX type of central conditioning systems:

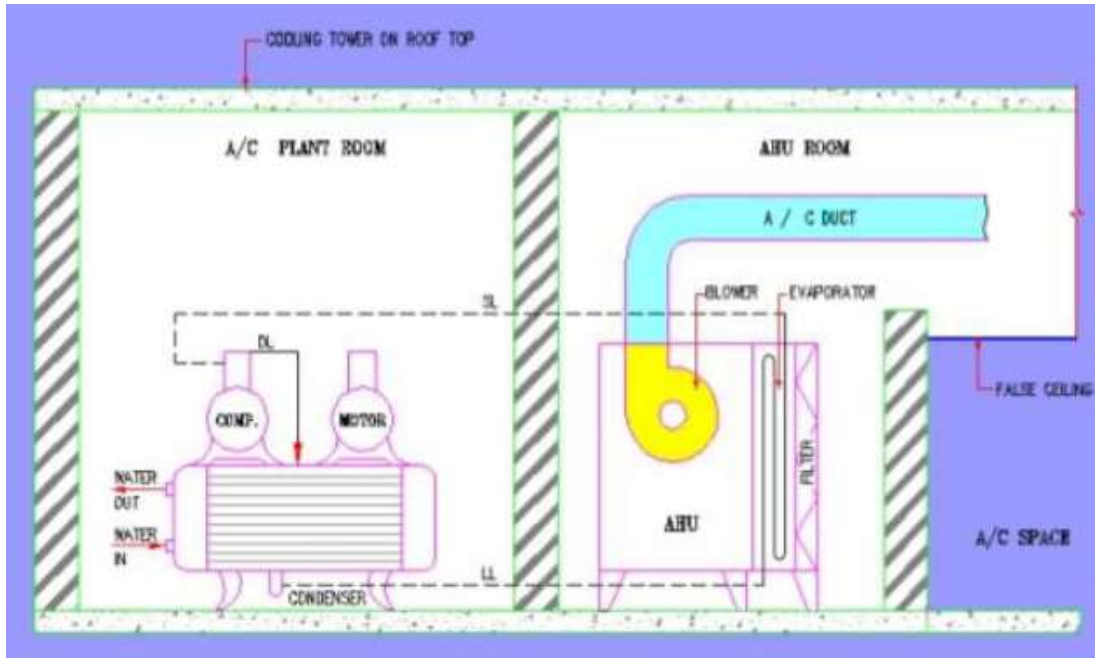
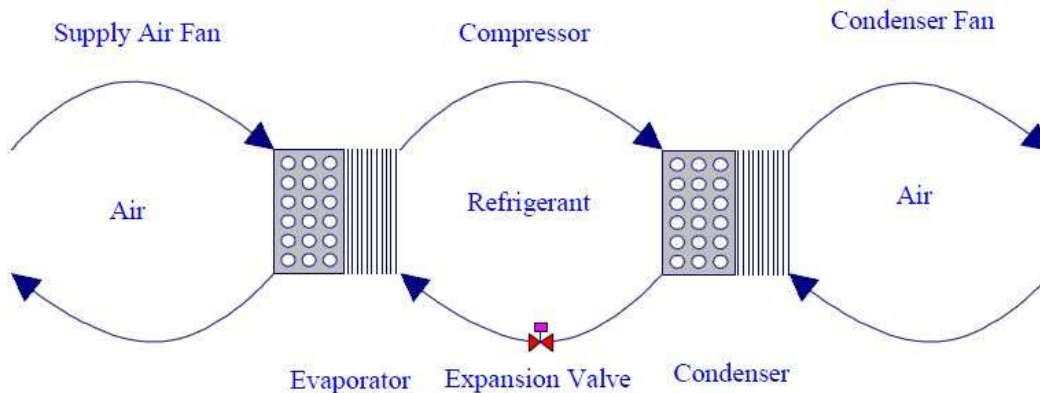

Figure: DX Central Air Conditioning Plant



1) The Plant Room:

- The plant room comprises of the important parts of the refrigeration system, the compressor and the condenser.
- The compressor can be either semi-hermetically sealed or open type. The semi-hermetically sealed compressors are cooled by the air, which is blown by the fan, while open type compressor is water cooled.
- The open compressor can be driven directly by motor shaft by coupling or by the belt via pulley arrangement.
- The condenser is of shell and tube type and is cooled by the water. The refrigerant flows along the tube side of the condenser and water along the shell side, which enables faster cooling of the refrigerant.

- The water used for cooling the compressor and the condenser is cooled in the cooling tower kept at the top of the plant room, though it can be kept at other convenient location also.

2) The Air Handling Unit Room:

- ★ The refrigerant leaving the condenser in the plant room enters the thermostatic expansion valve and then the air handling unit, which is kept in the separate room.
- ★ The air handling unit is a large box type of unit that comprises of the evaporator or the cooling coil, air filter and the large blower.
- ★ After leaving the thermostatic expansion valve the refrigerant enters the cooling coil where it cools the air that enters the room to be air conditioned.
- ★ The evaporator in the air handling unit of the DX central air conditioning system is of coil type covered with the fins to increasing the heat transfer efficiency from the refrigerant to the air.
- ★ There are two types of ducts connected to the air handling unit: for absorbing the hot return air from the rooms and for sending the chilled air to the rooms to be air conditioned.
- ★ The blower of the air handling unit enables absorbing the hot return air that has absorbed the heat from the room via the ducts. This air is then passed through the filters and then over the cooling coil.
- ★ The blower then passes the chilled air through ducts to the rooms that are to be air conditioned.
- ★ The DX expansion system runs more efficiently at higher loads. Even in case of the breakdown of the plants, the other plants can be used for the cooling purpose.
- ★ The DX types of central air conditioner plants are less popular than the chilled water type of central conditioning plants.

3) Air Conditioned Room:

- This is the space that is to be actually cooled. It can be residential room, room of the hotel, part of the office or any other suitable application.
- The ducts from the air handling room are passed to all the rooms that are to be cooled. The ducts are connected to the grills or diffusers that supply the chilled air to the room.
- The air absorbs the heat and gets heated and it passes through another set of the grill and into the return air duct that ends into the air handling unit room. This air is then re-circulated by the air handling unit.
- Though the efficiency of the DX plants is higher, the air handling units and the refrigerant piping cannot be kept at very long distance since there will be lots of drop in pressure of the refrigerant along the way and there will also be cooling losses.
- Further, for the long piping, large amounts of refrigerant will be needed which makes the system very expensive and also prone to the ma instance problems like the leakage of the refrigerant.

- Due to these reasons the DX type central air conditioning systems are used for small air conditioning systems of about 5 to 15 tons in small buildings or the number of rooms on a single floor.
- If there are large air conditioning loads, then multiple direct expansion systems can be installed. In such cases, when there is lesser heat load one of the plants can be shut down and the other can run at full load.
- The DX expansion system runs more efficiently at higher loads. Even in case of the breakdown of the plants, the other plants can be used for the cooling purpose.
- The DX types of central air conditioning plants are less popular than the chilled water type of central conditioning plants.

Chilled Water Central Air Conditioning Systems

Chilled Water Central Air Conditioning Plants

- ★ The chilled water types of central air conditioning plants are installed in the place where whole large buildings, shopping mall, airport, hotel, etc, comprising of several floors are to be air conditioned.
- ★ While in the direct expansion type of central air conditioning plants, refrigerant is directly used to cool the room air; in the chilled water plants the refrigerant first chills the water, which in turn chills the room air.
- ★ In chilled water plants, the ordinary water or brine solution is chilled to very low temperatures of about 6 to 8 degree Celsius by the refrigeration plant. This chilled water is pumped to various floors of the building and its different parts.
- ★ In each of these parts the air handling units are installed, which comprise of the cooling coil, blower and the ducts.
- ★ The chilled water flows through the cooling coil. The blower absorbs return air from the air conditioned rooms that are to be cooled via the ducts. This air passes over the cooling coil and gets cooled and is then passed to the air conditioned space.

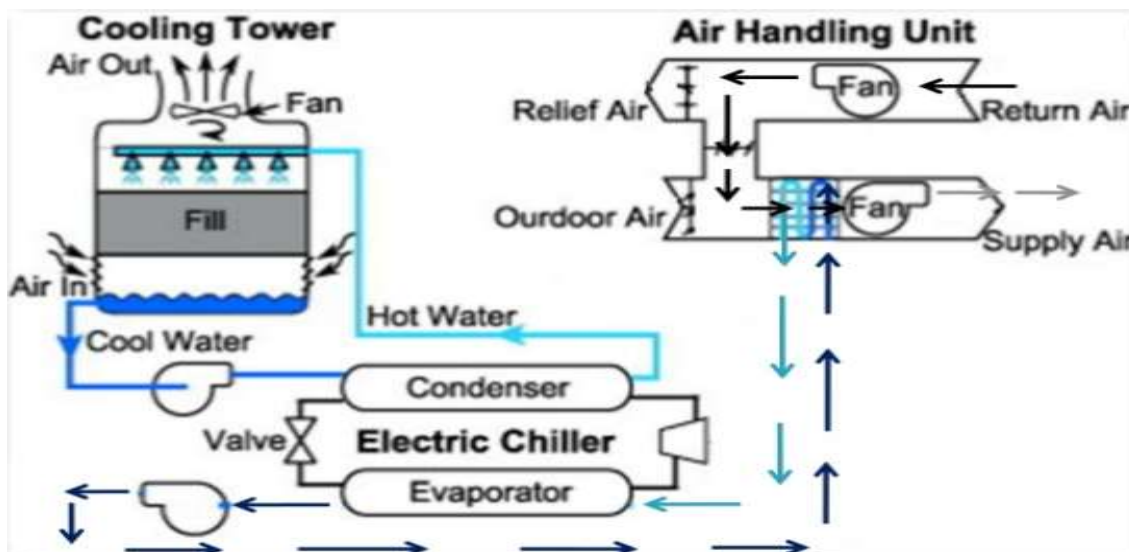

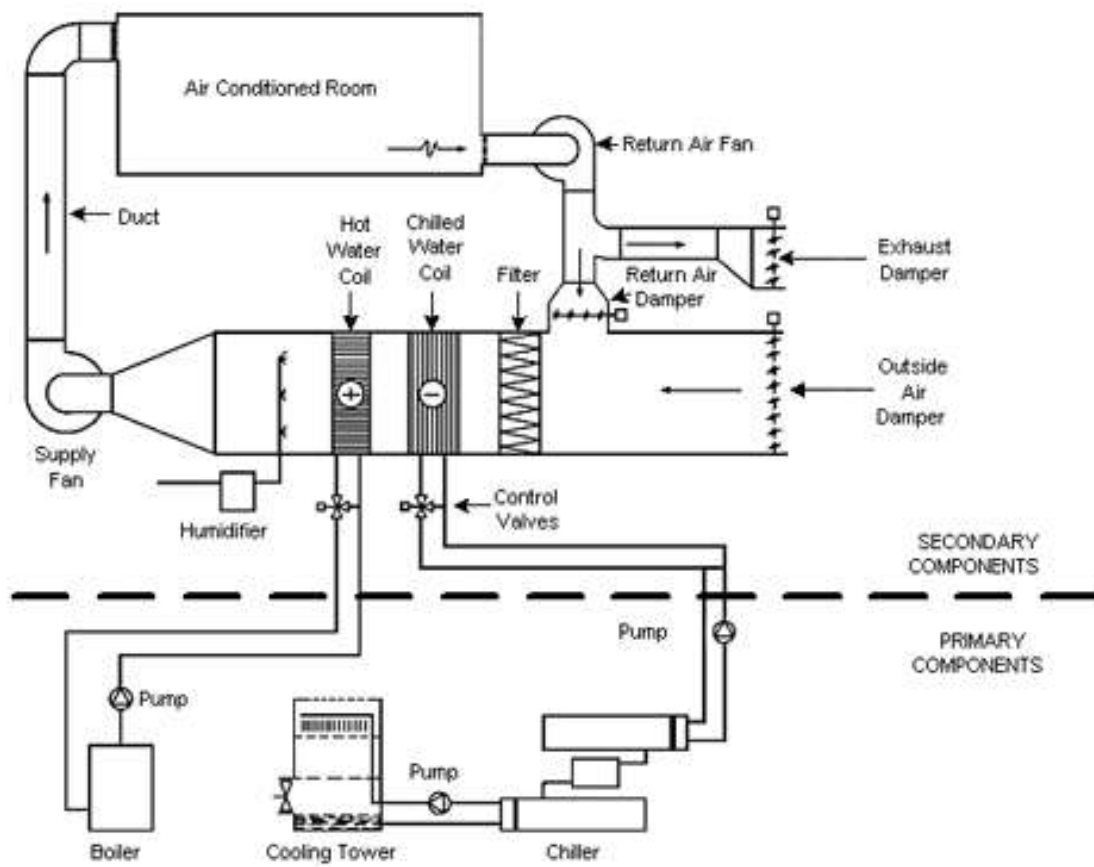

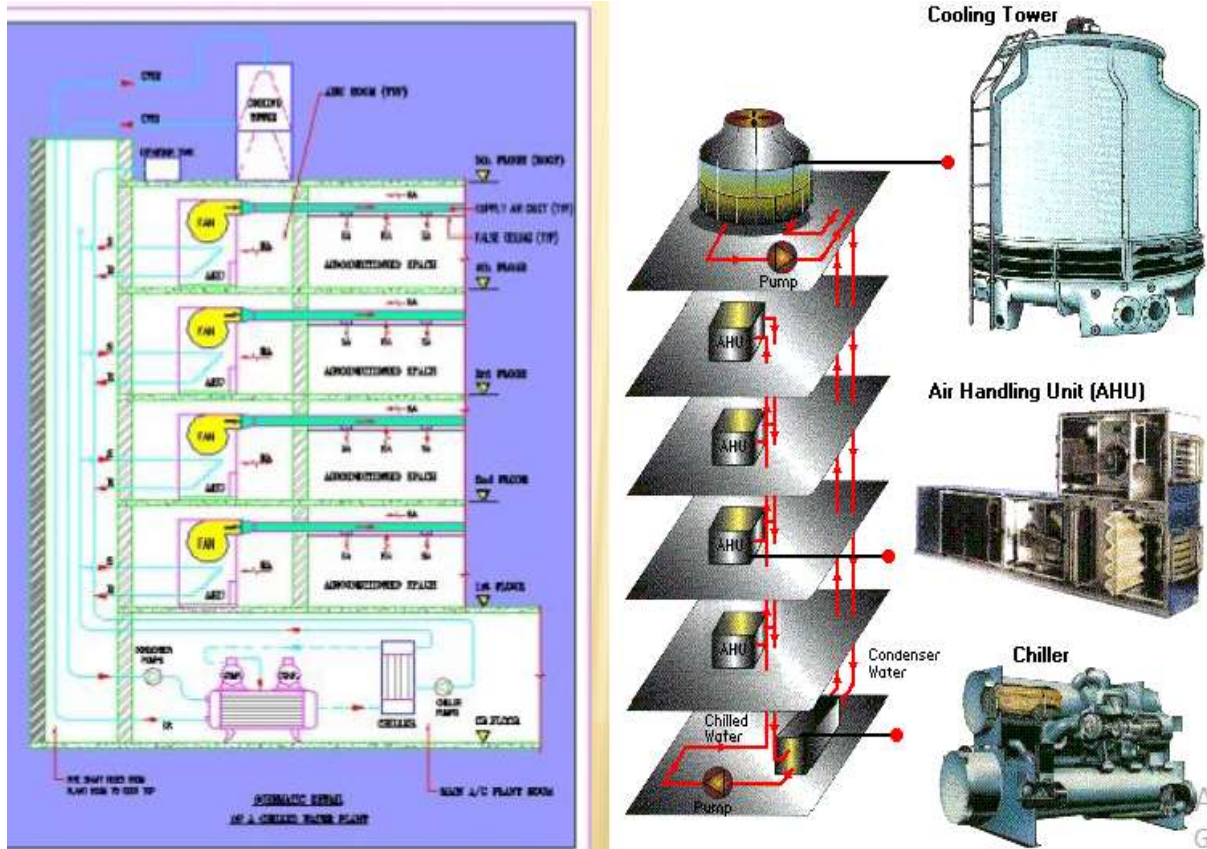

Various Parts of the Chilled Water Air Conditioning Plant

All the important parts of the chilled water air conditioning plant are shown in the above figure and described in detail below:

1) Central Air Conditioning Plant Room:

- ★ The plant room comprises of all the important components of the chilled water air conditioning plant. These include the compressor, condenser, thermostatic expansion valve and the evaporator or the chiller.
- ★ The compressor is of open type and can be driven by the motor directly or by the belt via pulley arrangement connected to the motor. It is cooled by the water just like the automotive engine.
- ★ The condenser and the evaporator are of shell and tube type. The condenser is cooled by the water, with water flowing along the shell side and refrigerant along the tube side. The thermostatic expansion valve is operated automatically by the solenoid valve.
- ★ The evaporator is also called as the chiller, because it chills the water. If the water flows along the shell side and refrigerant on the tube side, it is called as the dry expansion type of chiller.
- ★ If the water flows along tube side and the refrigerant along the shell side, it is called as the flooded chiller.

- ★ The water chilled in the chiller is pumped to various parts of the building that are to be air conditioned. It enters the air handling unit, cools the air in cooling coil, absorbs the heat and returns back to the plant room to get chilled again.
- ★ The amount of water passing into the chiller is controlled by the flow switch.
- ★ In the central air conditioning plant room all the components, the compressor, condenser, thermostatic expansion valve, and the chiller are assembled in the structural steel framework making a complete compact refrigeration plant, known as the chiller package.
- ★ Piping required to connect these parts is also enclosed in this unit making a highly compact central air conditioning plant.
- ★ The air handling units are installed in the various parts of the building that are to be air conditioned, in the place called air handling unit rooms. The air handling units comprise of the cooling coil, air filter, the blower and the supply and return air ducts. The chilled water flows through the cooling coil.
- ★ The blower absorbs the return hot air from the air conditioned space and blows it over the cooling coil thus cooling the air.
- ★ This cooled air passes over the air filter and is passed by the supply air ducts into the space which is to be air conditioned. The air handling unit and the ducts passing through it are insulated to reduce the loss of the cooling effect.

2) Air Handling Unit Rooms:

- The air handling units are installed in the various parts of the building that are to be air conditioned, in the place called air handling unit rooms.
- The air handling units comprise of the cooling coil, air filter, the blower and the supply and return air ducts.
- The chilled water flows through the cooling coil. The blower absorbs the return hot air from the air conditioned space and blows it over the cooling coil thus cooling the air.
- This cooled air passes over the air filter and is passed by the supply air ducts into the space which is to be air conditioned. The air handling unit and the ducts passing through it are insulated to reduce the loss of the cooling effect.

3) Air Conditioned Rooms:

- These are the rooms or spaces that are to be air conditioned. These can be residential or hotel rooms, halls, shops, offices, complete theater, various parts of the airport etc.
- At the top of these rooms the supply and the return air ducts are laid. The supply air ducts supply the cool air to the room via one set of the diffusers, while the return air ducts absorb the hot return air from the room by another set of the diffusers.
- The hot return air enters the air handling unit, gets cooled and again enters the room via supply duct to produce air conditioning effect.

4) Cooling Tower:

- The cooling tower is used to cool the water that absorbs heat from the compressor and the condenser.
- When water flows through these components some water gets evaporated, to make up this loss some water is also added in the cooling tower.
- The cooling tower is of evaporative type. Here the water is cooled by the atmospheric air and is re-circulated through the compressor and the condenser.

1.19 FAN COIL UNIT

Fan-coil units Fan-coil unit is considerably small unit used for heating and cooling coils, circulation fan, and proper control system, as shown in Figure. The unit can be vertically or horizontally installed. The fan-coil unit can be placed in the room or exposed to occupants, so it is essential to have appropriate finishes and styling. For central systems, the fan-coil units are connected to boilers to produce heating and to water chillers to produce cooling to the conditioned space. The desired temperature of a zone is detected by a thermostat which controls the water.

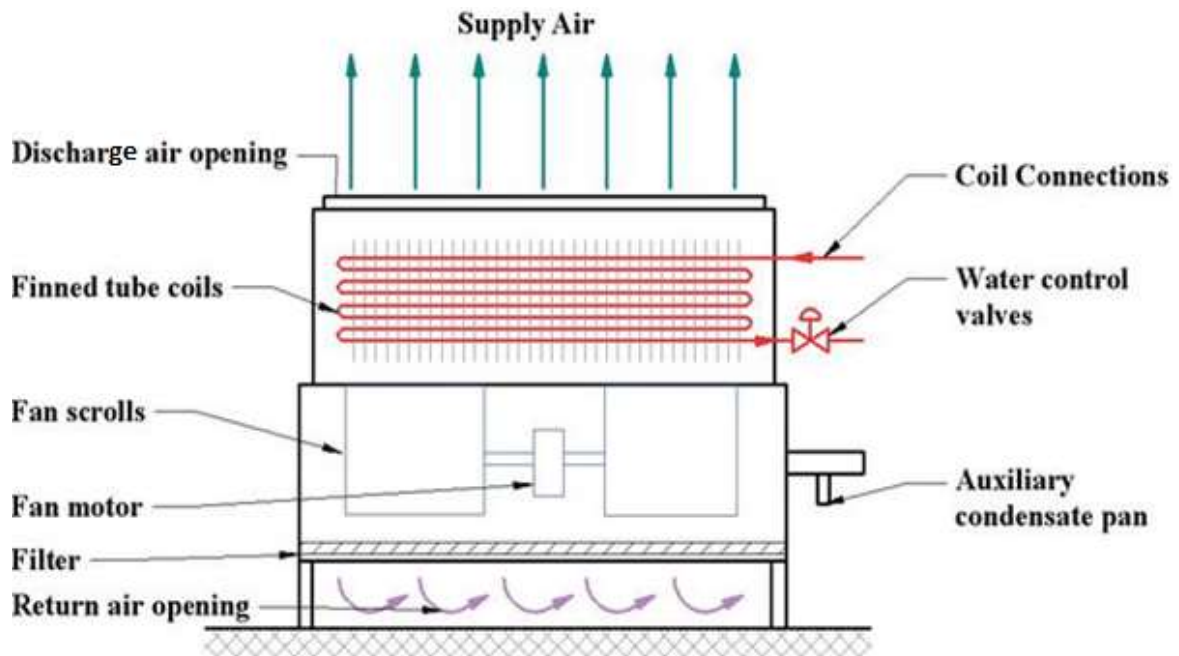

1.20 DISTRICT COOLING SYSTEM

What is District Cooling?

Basically, a district cooling system (DCS) distributes cooling capacity in the form of chilled water or other medium from a central source to multiple buildings through a network of underground pipes for use in space and process cooling. Individual user purchases chilled water for their building from the district cooling system operator and do not need to install their own chiller plants. For this system, a central chiller plant, a pump house and a distribution pipeline network are required.

The DCS is an energy-efficient air-conditioning system as it consumes 35% and 20% less electricity as compared with traditional air-cooled air-conditioning systems and individual water-cooled air-conditioning systems using cooling towers respectively. In some countries that have substantial heating demand, the plant can also be designed to supply hot water to form a District Heating and Cooling System (DHCS).

A typical DCS comprises the following components:

- Central Chiller Plant - generate chilled water for cooling purposes.
- Distribution Network - distribute chilled water to buildings
- User Station - interface with buildings' own air-conditioning circuits.

Central Chiller Plant

Chilled water is typically generated at the central chiller plant by compressor driven chillers, absorption chillers or other sources like ambient cooling or “free cooling” from deep lakes, rivers, aquifers or oceans.

Groups of large and energy-efficient water-cooled chillers are usually installed in a central chiller plant to take advantage of the economy of scale and the cooling demand diversity between different buildings within a district. Sea water condensers or fresh water cooling towers can be utilized to reject waste heat from the central chillers.

Distribution Network

District chilled water is distributed from the cooling source(s) to the user stations through supply pipes and is returned after extracting heat from the building’s secondary chilled water systems. Pumps distribute the chilled water by creating a pressure differential between the supply and return lines.

User Station

The interface between the district cooling system and the building cooling system is commonly referred to as user station. The user station would usually comprise of air handling units, heat exchanger and chilled water piping in the building. A user station is required in each user's building to connect the DCS distributed chilled water pipe to the building. Inside the user station, devices called heat exchangers are installed to transfer heat between the chilled water supply of DCS and the air-conditioning system of the user building. The user station could be designed for direct or indirect connection to the district cooling distribution system. With direct connection, the district cooling water is distributed within the building directly to terminal equipment such as air handling and fan coil units, induction units, etc. An indirect connection utilizes one or multiple heat exchangers in between the district system and the building system.

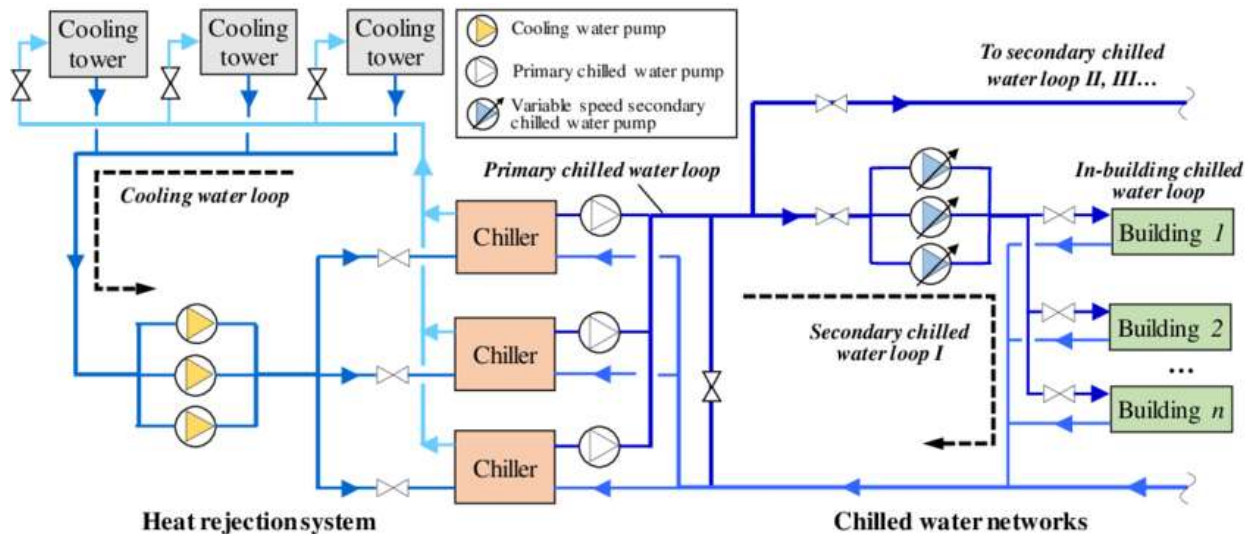

1.21 ENERGY EFFICIENT SYSTEMS

Each air conditioner has an energy-efficiency rating that lists how many Btu per hour are removed for each watt of power it draws. For room air conditioners, this efficiency rating is the Energy Efficiency Ratio (EER), while for central air conditioners, it is the Seasonal Energy Efficiency Ratio (SEER). As explained in [EnergyStar](#), the EER is a measure of how efficiently a cooling system will operate when the outdoor temperature is at a specific level (95oF). In normal terms, the higher the EER, the more efficient the system is. In technical terms, EER is the steady-state rate of heat energy removal (i.e. cooling capacity) by the product measured in Btuh divided by the steady-state rate of energy input to the product measured in watts. This ratio is expressed in Btuh/watt. The SEER measures how efficiently a cooling system will operate over an entire season, and the higher the SEER the more efficient the system is. In technical terms, SEER is a measure of equipment the

total cooling of a central air conditioner or heat pump (in Btu) during the normal cooling season as compared to the total electric energy input (in watt-hours) consumed during the same period. An important direct measure of efficiency is the coefficient of performance (COP), which demonstrates the cooling power of an air conditioning system divided by fan and compressor power.

Room air conditioners generally range from 5,500 Btu per hour to 14,000 Btu per hour. There are several appliance standards worldwide, which require a minimum EER for room air conditioners (for instance in the USA these must be 8.0 or greater). For milder climates an efficient air conditioning system could have a minimum 9 EER, while for hotter climates this should be over 10. As far as the smaller portable air conditioning units are concerned, the least efficient unit has an EER of less than 1.5.

1.22 ENVIRONMENTAL IMPACT OF AIR CONDITIONERS

CFCs/ HFCs

Air conditioners are complex machines that are made up of many different parts which work in several ways. CFCs and HFCs are both cooling agents that are in the air conditioners which, when released, increases the holes in the ozone over time.

Older air conditioners rely on CFC and HCFC and contribute to global warming in a major way. Even newer models, which rely more on HFCs and HFOs play a large role in ozone depletion.

Energy use

Air conditioners require lots of energy to function properly. It consumes so much electricity and therefore releases pollution. When fossil fuel is burned, carbon dioxide is also released into the air, more commonly known as a greenhouse gas, which is a major contribution to ozone depletion.

The average and typical air conditioner will consume about 3000 to 5000 watts of electricity every hour, depending on the season – the warmer, the more power used. This is clearly very harmful to the environment, as well as extremely expensive.

Unclean ducts

It is important to note that air conditioners do not only affect the environment in a global way, it also affects it on a small scale as well. The ducts in each air conditioner, over time, collect dust and bacteria and every time the air conditioner is turned on, both are released, and are toxic for humans, especially children.

There are ductless **mini-split brands** though that focus more on the environment and safety of people. Ductless mini-split brands are actually more durable and work in warmer climates such as Middle East, Asia and Central and South America.

Materials used

In the past air conditioners were mainly made out of metals. Though over the years, people decided that metal is too expensive and too heavy, so they opted for plastic. Although metal and plastic are both harmful to the environment, plastic is completely non-biodegradable, which makes it an enemy of the environment. The production of plastic alone is extremely detrimental, as it too releases carbon dioxide into the air and causes what we now know as the greenhouse effect.

It is important to note that air conditioners can sometimes be vital for mere survival. There are places, due to global warming, that are extremely warm and need the presence of coolant. Though this turns into a cycle since ACs contribute to global warming, we undoubtedly still need them in order to survive the rising temperatures, whether it's at home or in our working spaces. However, all is not lost as we still have the option of going with more eco-friendly air conditioners that can be both beneficial for your health as well as the world's health, and as technology advances, so do the efforts to make them less harmful to our environment.

1.23 LATEST INNOVATIONS IN AIR CONDITIONER

INVERTER TECHNOLOGY

An inverter is a device for converting frequency. The technology is used in many home appliances and controls electric voltage, current and frequency. Inverter air-conditioners vary their cooling/heating capacity by adjusting the power supply frequency of their compressors.

An inverter type air-conditioner adjusts the speed of the compressor to control the refrigerant (gas) flow rate, thereby consuming less current and power. An inverter has precise temperature control and as the set temperature is attained, the unit adjusts its capacity to eliminate any temperature fluctuations.

In contrast, non-inverter air conditioners have a fixed cooling/ heating capacity and can only control the indoor temperature by starting or stopping their compressors.

Non-inverter air-conditioners stop and start repeatedly. The power consumption and current goes down when the operation stops, but it goes up sharply at the time of restart and thus it has high average power consumption and temperature variations. As a result, inverter air conditioners are more energy-saving and comfortable than non-inverter air-conditioners.

Let's take an example of [1.5 Ton AC](#). Inverter AC can work from 3 to 1.7 ton based on cooling requirement. Non-inverter AC can work at 1.5 ton only (fixed capacity).

Inverter power control

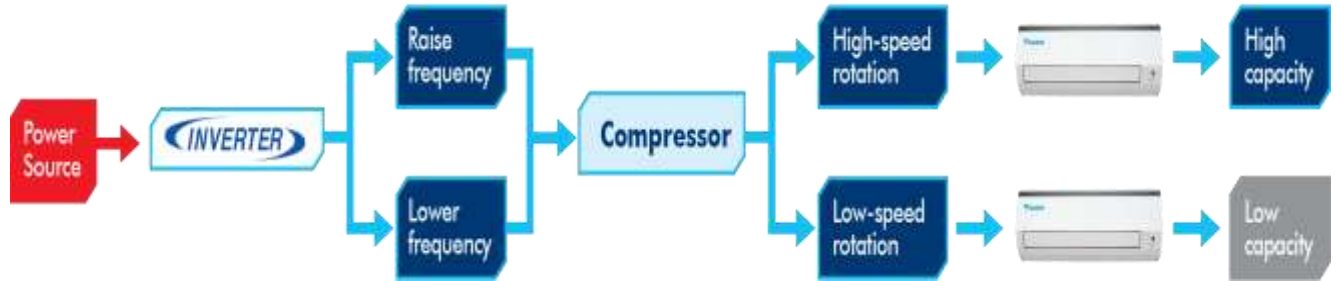

Non-inverter type air-conditioner



Inverter air-conditioners are able to vary their operating capacity. Non-inverter air-conditioners can only operate at a fixed capacity.



Figure: Inverter AC (Scenario: Indoor Temperature: 22 Degree, Set Temperature: 22 Degree)

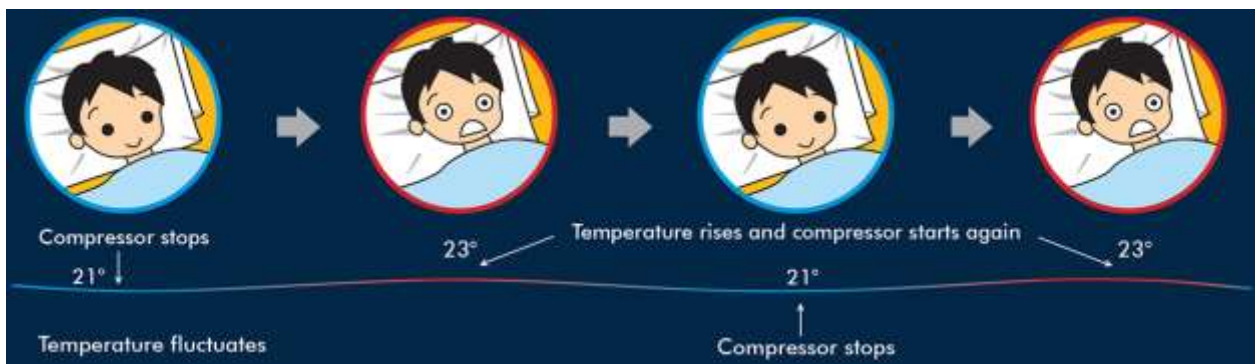
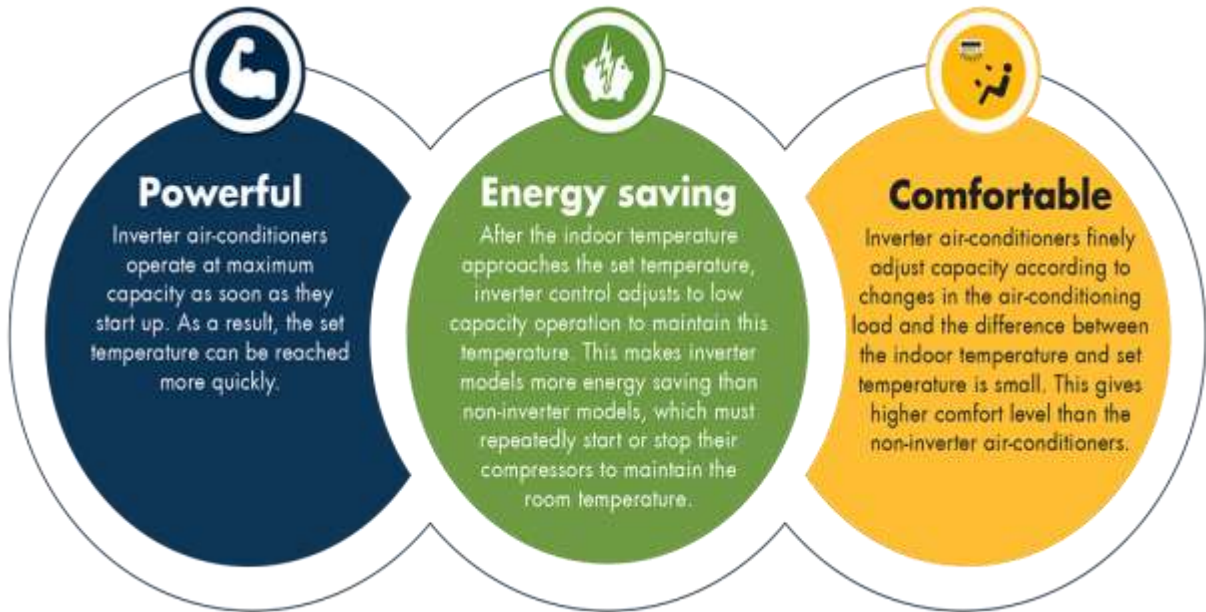

Figure: Non Inverter AC

Benefits of inverter AC



UNIT 2

DESIGN ASPECTS OF AIR CONDITIONING SYSTEMS

SYLLABUS

- Design criteria for selection of air conditioning.
- Configuring/ sizing of mechanical equipment, equipment and spaces for them.
- Horizontal and vertical distribution of services for large buildings.

2.1 SELECTION CRITERIA FOR AIR CONDITIONING SYSTEMS:

Selection of a suitable air conditioning system depends on:

- Capacity, performance and spatial requirements
- Initial and running costs
- Required system reliability and flexibility
- Maintainability
- Architectural constraints
 - ★ The relative importance of the above factors varies from building owner to owner and may vary from project to project.
 - ★ The typical space requirement for large air conditioning systems may vary from about 4 percent to about 9 percent of the gross building area, depending upon the type of the system.
 - ★ Normally based on the selection criteria, the choice is narrowed down to 2 to 3 systems, out of which one will be selected finally.
 - ★ Architectural Constraints Designing air conditioning for different building applications and occupancies requires a consideration of different design criteria, operating hours, and different system characteristics.
 - ★ Specific design criteria usually dictate the type of air conditioning system that should be selected.
 - ★ A good example is the design of an air conditioning system for a class 10 clean room for fabrication of semiconductor wafer. In this case a constant-volume central system is always the preferred option.
 - ★ When the clean room is in operation, adequate clean air must be provided to maintain unidirectional flow to prevent the contamination of semiconductor wafers by sub micrometer-size particulates.
 - ★ It should be noted that a constant-volume system with electric terminal reheat is always preferable to a VAV system in places requiring high precision constant temperature to be maintained in the conditioned space.

- ★ For guest rooms in luxury hotels, a four-pipe fan-coil system is the most widely used air conditioning system as in addition to the systems ease of maintenance, the four-pipe fan-coil system provides individual temperature and fan speed controls as well as a positive supply of adequate outdoor ventilation air. When the room is not occupied, the fan coil unit (in the room) can be turned off conveniently.
- ★ Space limitations specified by the architect or facility owner also influence the selection of the air conditioning system.
- ★ For example where the design for a high-rise building provides no Rooftop space for AHUs and other mechanical equipment, or if there is not enough space for supply and return duct shafts, a floor-by-floor AHU central system may be the practical choice.
- ★ Capacity and Performance Requirements Another vital consideration for the selection of air conditioning system is the system capacity.
- ★ For a single-story small retail shop, a constant-volume packaged system is often chosen. If the conditioned space is a large indoor stadium with a seating capacity of up to 70,000 spectators, a single-zone VAV central system is often selected. This system also guarantees the provision of minimum ventilation controls for required indoor air quality regulation.
- ★ Maintenance Considerations It is worth mentioning here that a central system with AHUs, a few water-cooled centrifugal chillers, and cooling towers needs less maintenance work than a packaged system with many rooftop air-cooled units.
- ★ A VAV reheat central system needs less maintenance work in the fan and plant rooms than fan-coil system, which often requires much maintenance work in the ceiling space directly above the conditioned space.
- ★ Cost Considerations Initial cost and operating costs (mainly energy cost) are always primary factors that affect the selection of an air conditioning system.

ENERGY CONSERVATION IN AIR- CONDITIONING SYSTEMS

- Balance air and water systems that are out of balance
- repair variable-air-volume boxes that are not working properly
- tighten loose fan belts
- repair leaking control valves
- replace leaking damper seals
- repair or replace malfunctioning variable-speed drives
- seal ductwork to minimize leaks
- Reduce excessive air-change rates.
- Building Envelope

(1)repair door and window seals to prevent excessive infiltration of unconditioned outdoor air and excessive exfiltration of conditioned air replace inefficient glazing or install

solar-control film provide internal or external shading devices to control solar-heat gain
Install additional thermal insulation where needed to reduce heat gain and loss.

(2) Two-speed cooling tower fans and variable-speed drives on fans and pumps and energy management systems (or direct digital control systems) will allow for the modulating of HVAC equipment. This controls the system so that it works only to meet the space conditioning and ventilation requirements of the building spaces, and not just at full output capacity at all times. For example, demand-controlled ventilation modulates ventilated air to keep CO₂ levels below a set point (for example, 1000 parts per million), thereby allowing ventilation rates to be adjusted to the number of people occupying the space and other variables. This strategy for reducing building ventilation saves energy without compromising indoor air quality, and modern CO₂ sensors are both reliable and inexpensive.

(3) The cost-effectiveness of installing direct digital controls (DDCs) on an HVAC system varies widely with the specific site and application. DDC systems save energy if they are used to turn building systems off when they are not needed. In office buildings, DDC systems can modulate HVAC and lighting equipment to achieve energy savings as well as to trim demand during peak periods, thereby lowering energy bills for months to come.

(4) Using occupancy sensors in conjunction with digital controls can limit energy waste in unoccupied hotel and motel rooms and similar spaces, including offices. Guest room occupancy sensors or central control systems can reduce energy requirements without inconveniencing guests. For example, a central switching system at the front desk can turn on heating or air conditioning as the guest checks in or manually adjust thermostat settings if the room is unoccupied. Heat sensing (infrared) detectors can activate HVAC and lighting systems based on human presence in the room. Turn-off time delays of 10 to 30 minutes can accommodate a guest's departure from the room for short periods of time.

(5) Variable air volume (VAV) air-handling systems with variable-speed drives (VSDs) can save considerable fan energy over constant volume systems. Incorporating a VSD on a VAV fan allows it to slow down as load decreases. Because reducing fan speed by one-half will reduce power consumption by seven-eighths, a VSD on a VAV fan system offers compound energy savings that can provide a payback of three to five years. Typical VSD installation costs are \$200 to \$250 per horsepower of the motor driven. VAV can save energy cost-effectively in systems whose fans are 20 hp or more.

(6) Variable-speed drives are also useful in a number of other commercial and industrial applications, from moving water from boilers or chillers to local heat exchangers to adjusting patterns of irrigation to optimize crop growth while minimizing water use. Motors used in pumping fluids like water or high-pressure air can match pumping rates to instantaneous demands, thereby saving both energy and demand costs.

(7)VSD's are also useful in adjusting ventilation rates to ensure good indoor air quality while controlling fan energy use. Instead of operating at fixed fan rates on a predetermined schedule, ventilation rates can be varied to maintain CO2 levels below a given threshold, for example, 1100 parts per million. Inserting a CO2 sensor in the return air stream to give feedback to a simple control algorithm can optimize fan use while safeguarding air quality.

2.2 CONFIGURING / SIZING OF MECHANICAL EQUIPMENT:

A method and system of managing a configuration of mechanical equipment provides a structured procedure.

It helps to manage various parameters of the mechanical equipment to facilitate the maintenance of safety, performance and reliability of the mechanical equipment.

Correct sizing of mechanical equipment is important for several reasons.

Mechanical equipment larger than needed results in inefficiencies of the system.

TYPE OF EQUIPMENT COMMONLY AVAILABLE RATINGS

Window and Split AC Min : 1 TR – Max : 2 TR

Packaged Air-conditioners Min : 5.5 TR – Max : 22 TR

Ductable Air-conditioners Min : 5.5 TR – Max : 22 TR

DX-System - Min : 12 TR – Max : 90 TR

EQUIPMENT SPACING :

While planning for the space requirements of AC Equipment rooms the following guidelines may be used.

TYPE OF EQUIPMENT SPACE REQUIREMENT

- Packaged unit room 3m x 2m – Single unit
- 3m x 4 m – Two units
- 3 m x 5 m – Three units
- AHU Rooms 4m x 3m – up to 30 TR
- 4m x 5 m – up to 60 TR
- Water Cooled chiller plants 6m x 6m for each plant and pumps. 3m x 3m open space for cooling tower.
- Air cooled chiller plants 10 m x 8 m open space for one plant and pumps.

Note the following:

- ★ Height of packaged unit room or the AHU room should be the same as that of the area to be air conditioned.
- ★ Ductable split units require minimum 600 mm clear space above false Ceiling to locate the indoor units and to run the ducts.
- ★ Equipment placing should be done with an eye on maintenance. Packaged unit should have 1 m space in front of the unit for unit servicing.
- ★ If it is water cooled 2 m at the side also required for condenser tube cleaning.
- ★ Shafts should be sized properly for installing the pipes based on site conditions.

2.3 HORIZONTAL & VERTICAL DISTRIBUTION OF SERVICES FOR LARGE BUILDINGS

- Under-floor distribution Air-conditioning system distribution and terminal equipment is generally located overhead in the ceiling void with the cool supply air entering the room from ceiling diffusers.
- However, the supply of conditioned air from under the floor is a design option. In this case, the air or water distribution and terminal devices are located in the floor void, and hence the overhead services are reduced to only lighting and sprinklers.
- By making the floor void deep enough, the power, telecommunications and computer wire ways may be incorporated into the one plenum, all being easily accessible by merely opening up the raised floor.
- Under-floor cooling is particularly beneficial for spaces such computer rooms, as air velocities from floor grilles and resultant noise levels are both much higher for cooling of equipment than those which would be acceptable for people.

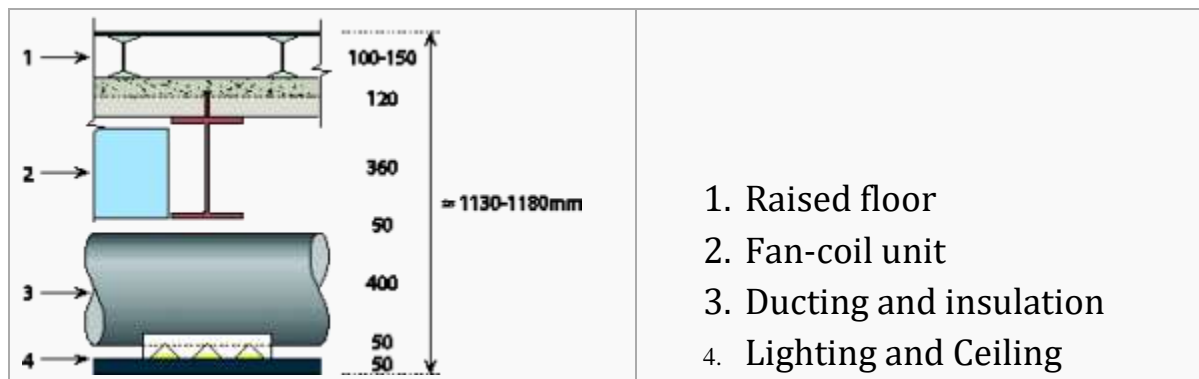

Services located below composite beams

- Internal distribution of services For many reasons, there is pressure to minimise the space allocated to the building services. Therefore, it is necessary to ensure an efficient use of space for the service distribution system in the vertical and horizontal directions and in the plant rooms.
- The following sections review the spatial aspects of the vertical and horizontal service distribution.
- Conventionally, the horizontal distribution of services is arranged within a horizontal layer which is generally located below the structure and above the suspended ceiling.

➤ This layer accommodates the distribution system (ducts, pipes, etc), the terminal units and lighting units. The raised floor is placed on the floor slab and accommodates the electrical and communication cabling. The lighting units are often located within the ceiling depth. To determine the spatial allowance for these elements, three design cases may be envisaged corresponding to different structural configurations:

1. A flat slab with flexibility of service routing.

2. A slab and down stand beam arrangement.

3. A long span beam system with facility for service integration in the structural depth.

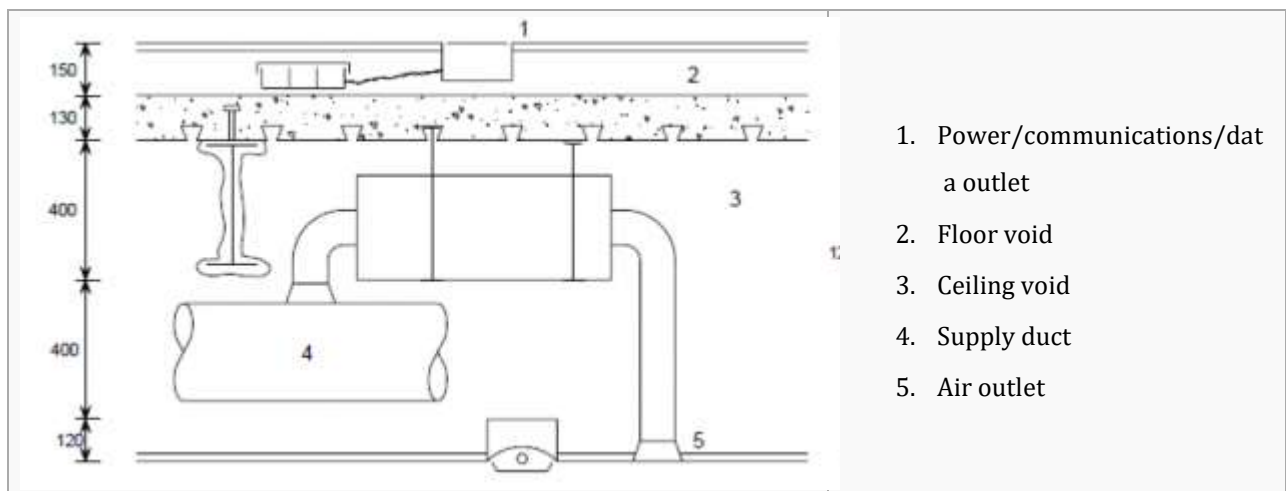

1. Power/communications/data outlet
2. Floor void
3. Ceiling void
4. Supply duct
5. Air outlet

Example of integrated services Case 2 – Slab and downstand beam arrangement

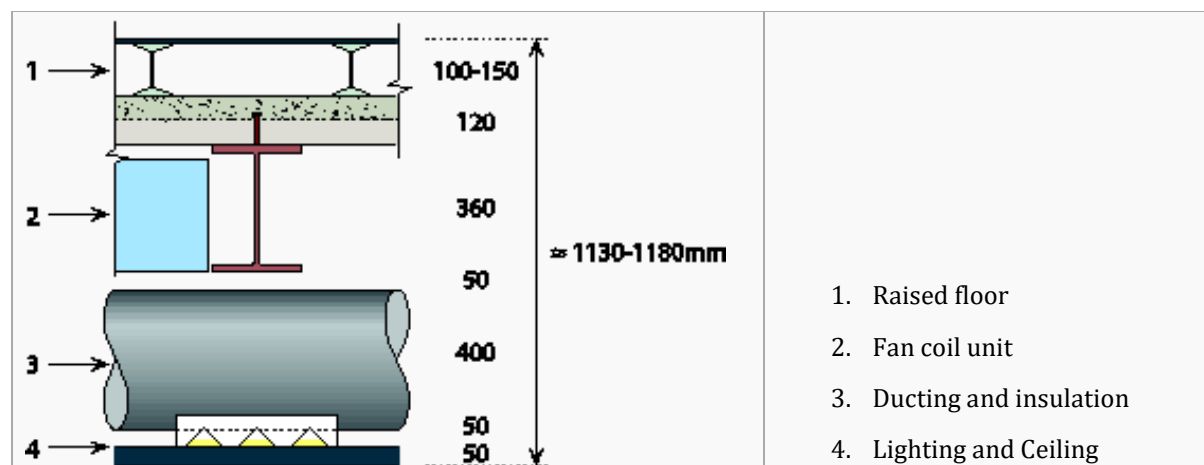

1. Raised floor
2. Fan coil unit
3. Ducting and insulation
4. Lighting and Ceiling

Services located below composite beams

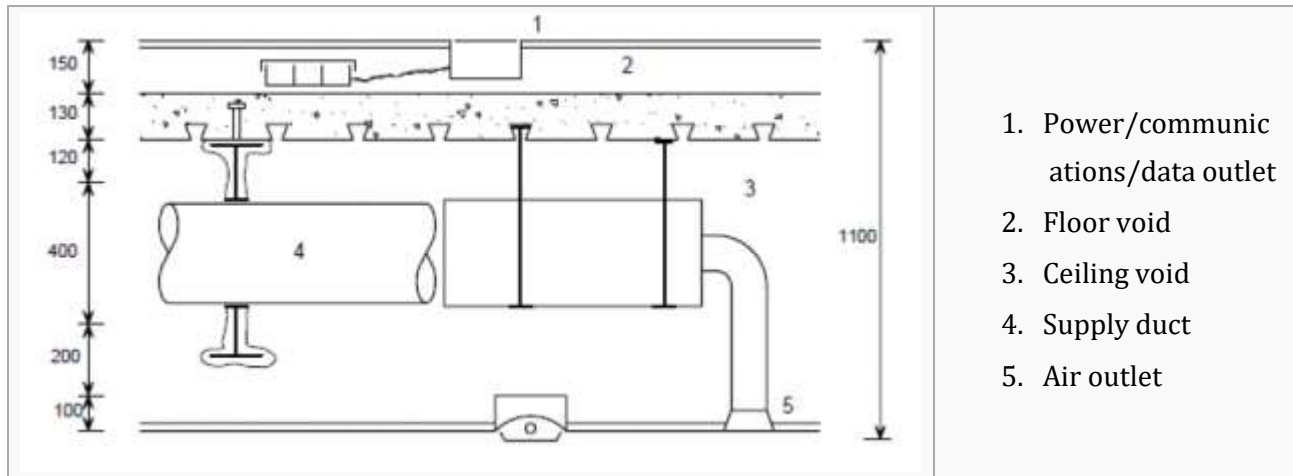

Example of integrated services Case 3 – Long span beam with web openings

In case 1, the ducts pass below the floor within the depth allowed for the terminal units. However, cross-overs of ducts must be avoided in order to minimize this depth. In cases 2 and 3, the terminal units may be located between the beams, which means that additional space below the beams is required only for the major ducts, ceiling and lighting units. In case 3, the ducts are located entirely within the structural zone as they pass through large openings in the deep beams. Typically, the diameter of these openings is 400mm, and the duct size is 300 or 350mm allowing for insulation etc. Vertical distribution of services

Vertical dimensions for the following components	Case 1 Flat soffit (mm)	Case 2 Downstand beams (mm)	Case 3 Long span beams (mm)
Allowance - deflection & fire protection	30	50	50 to 75
Lighting units and ceiling	100 to 150	100	100
VAV box and attachments	400	Nil (boxes between beams)	Nil
Ducts and insulation	<400 , but no cross-overs	400 (inc. insulation)	Nil- 400mm dia. openings
Total (below structure)	550	500	150 to 175
Raised floor	150	150	150
Structural depth (typical)	300 to 400	550	800 to 900
Total (ceiling-floor)	1,000 to 1,100	1,200	1,100 to 1,200

Typical vertical dimensions between ceiling and floor

The following recommendations apply to the vertical distribution of services:

- ✓ Provide continuous and uninterrupted vertical service routes
- ✓ Maintain a constant cross-section of the service route
- ✓ Position the plant room so that it is as close as possible to the centre of the plan area it serves
- ✓ Consider the connection between horizontal services and vertical services routes
- ✓ Provide separate routes for different services. The minimum is two; one for electrics and one for water pipes, etc., although most buildings require more service routes
- ✓ Horizontal distribution should ideally not extend more than 25 m from a vertical service route. Longer distances will impose penalties on the system design and increase the depth of horizontal service ducts
- ✓ Position plant rooms at no more than 10 storeys apart vertically.

The figure shows typical arrangements of vertical service routes. Vertical ducts which transfer air from the roof-top plant to each floor can often be concentrated in a relatively small riser, as shown below

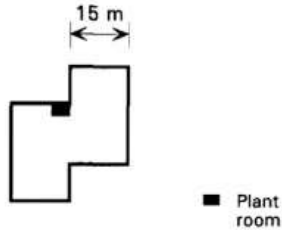
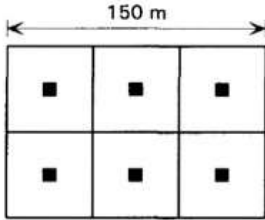
Type	Plant	Notes
Small building (up to four storeys and up to 2500 m ² total floor area)		One plant room, one riser. Location of riser not important, due to small size of building (central location preferred). Plant room must be adjacent to the riser
Large plan building (4000 m ² total floor area)		Several plant rooms adjacent to areas served. Some central plant, for example for gas intake and boilers, may be required

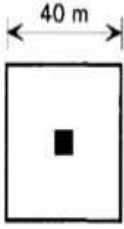
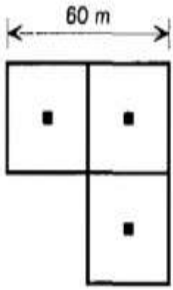
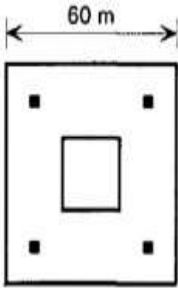
<p>Large, tall building (over 15 storeys)</p>	 <p>A diagram of a large, tall building with a 40m wide central core. The building is represented as a vertical rectangle with a smaller square in the center. A dimension line above the central square indicates a width of 40 m.</p>	<p>Plant room floors at basement and roof level. Intermediate plant rooms may be required. Vertical distribution within central core</p>
<p>L-shaped building (1000 m² to 3000 m² per floor), (3 -10 storeys)</p>	 <p>A diagram of an L-shaped building with a 60m wide core. The building is represented as an L-shaped polygon with three small squares representing plant rooms. A dimension line above the top horizontal part indicates a width of 60 m.</p>	<p>Several plant rooms, several risers. Risers and air plant rooms adjacent to cores. Separate room located at ground/basement level for new electric supply</p>
<p>Building with atrium (typically 2000 m² per floor), (5 - 10 storeys)</p>	 <p>A diagram of a building with an atrium and a 60m wide core. The building is represented as a large square with a smaller square in the center. Four small squares representing plant rooms are located at the corners of the large square. A dimension line above the top horizontal part indicates a width of 60 m.</p>	<p>Four roof air plant rooms, one basement plant room. Four risers related to cores. Basement plant below atrium gives best connection to risers</p>

Typical arrangements of plant rooms and vertical service routes

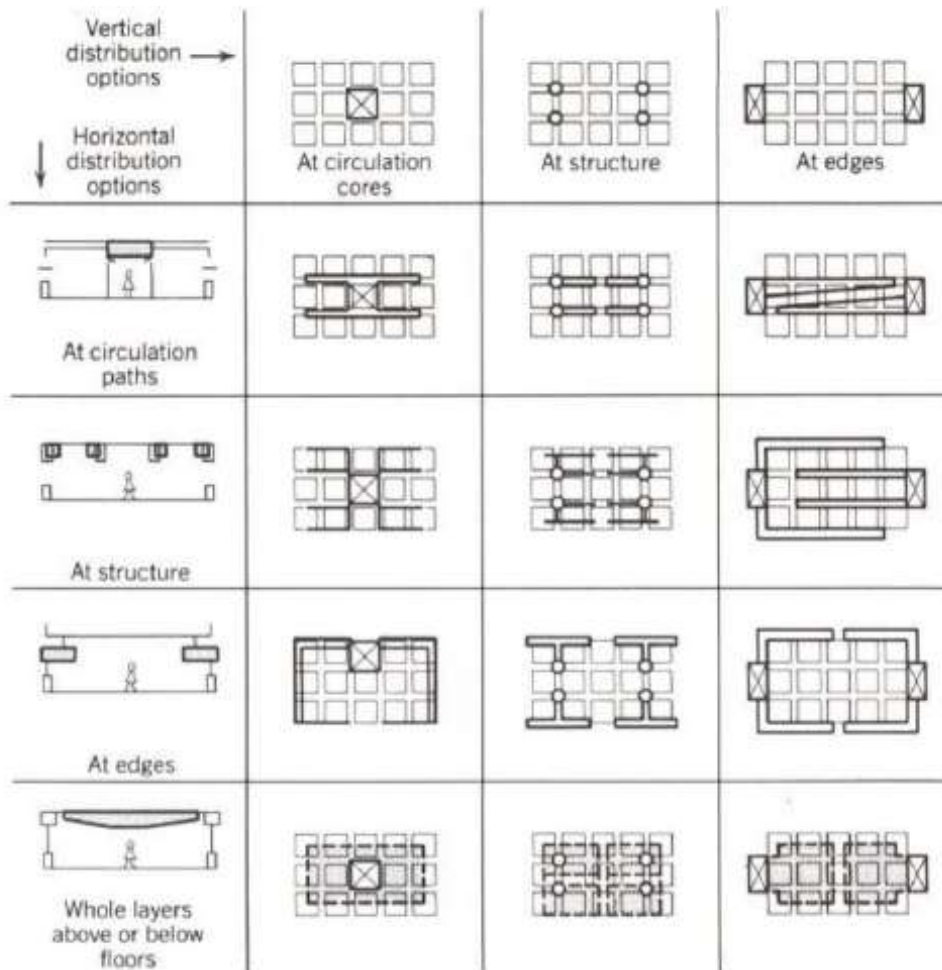

HORIZONTAL DISTRIBUTION OF SERVICES THROUGH CENTRAL CORRIDOR

- ★ The horizontal distribution system for mechanical and electrical services should be planned simultaneously with the structural frame and the interior finish systems, because the three are strongly interrelated.
- ★ The floor to floor height of a building is determined in part by the vertical dimension needed at every story for horizontal runs of duct work and piping.
- ★ The selection of finish ceiling, partition and floor systems is often based on their ability to contain the necessary electrical and mechanical services and to adjust to future changes in these services. All these strategies involve close cooperation among the architect and the structural and mechanical engineers.
- ★ Plumbing walls, they will not interfere with other services. Sprinkler heads which have the next highest priority in the layout of horizontal services are served from the fire stand pipe by horizontal piping that seldom exceeds 4 in. (100mm) in outside diameter.
- ★ The spacing of the heads is coordinated with the placement of walls and partitions the maximum coverage per head is about 200 sq. ft. (18.6 m²) in light hazard buildings such as churches, schools, hospitals, office buildings, museums and auditoriums. Coverage in industrial and storage buildings ranges from 130 to 90 sq. ft. (12.1 to 8.4 m²) per head, depending on the substances handled in the building.

- ★ Air conditioning ducts, the next priority branch out from a local fan room or from a vertical ducts in supply and return ducts. Return ducts are often very short and confined to the interior areas of the building.
- ★ Supply ducts extend through low velocity secondary ducts to air diffusers throughout the occupied area of the floor. Diffusers are generally required at the rate of four to seven diffusers per 1000 sq. ft. (100m²).

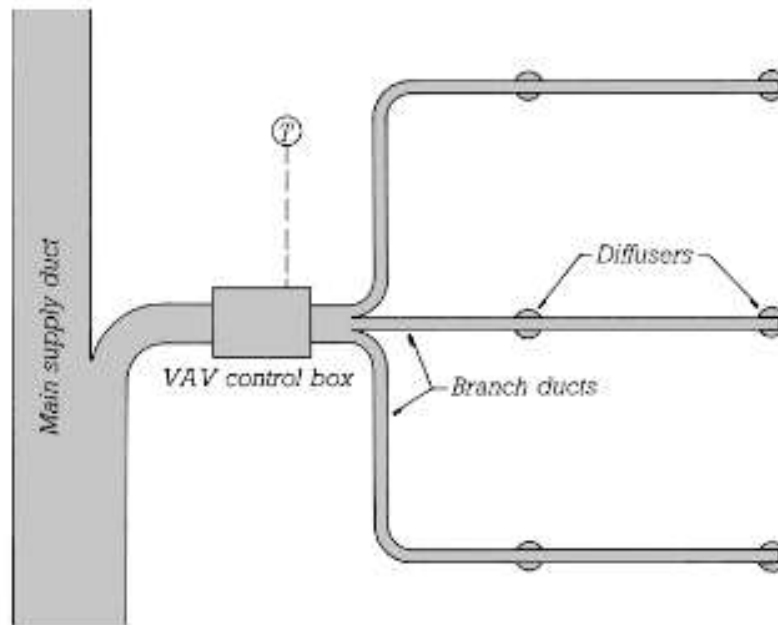

Figure: Plan of VAV Duct

GROUPED HORIZONTAL DISTRIBUTION OVER CENTRAL CORRIDORS:

- ★ Sometimes the major runs of duct work, piping and wiring can be grouped in the ceiling area above the central corridor of each floor of a building, leaving the ceilings of the surrounding rooms essentially clean.
- ★ This works especially well in hotels and apartment buildings that rely on above ceiling all water or electric equipment adjacent to corridor for heating, cooling and ventilating.
- ★ A low corridor ceiling is readily accepted in exchange for high, unobstructed space in the occupied rooms, where the structure may be left exposed as the finish ceiling, saving cost and floor to floor height.
- ★ If the building has a two way flat plate or hollow core precast slab floor structure, the overall thickness of the ceiling floor structure can be reduced to as little as 8 in. (200 mm) Conduits containing wiring for the lighting fixtures may be cast into the floor slabs or exposed on the surface of the ceilings.

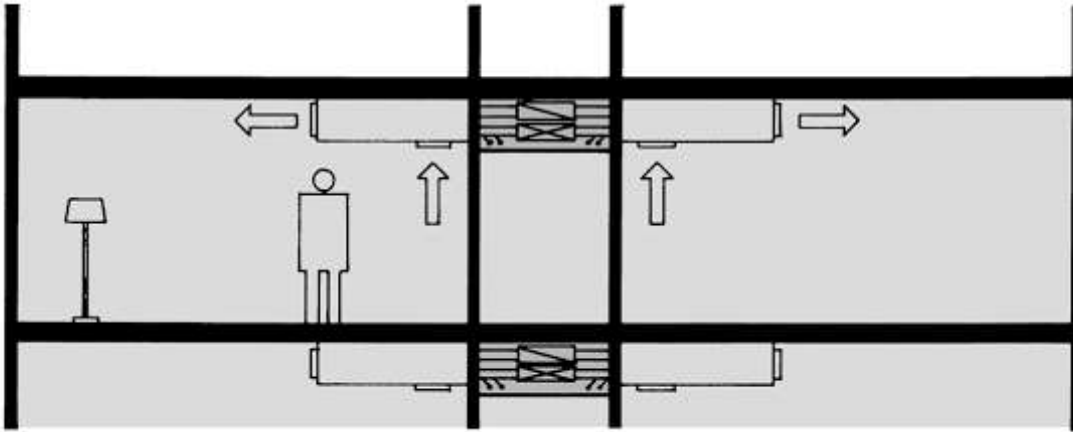

Figure: Grouped Horizontal Distribution over a Central Corridor

IN FLOOR AND RAISED ACCESS FLOOR DISTRIBUTION OF MECHANICAL SERVICES:

- ★ **Underfloor air distribution (UFAD)** is an air distribution strategy for providing ventilation and space conditioning in buildings as part of the design of an HVAC system.
- ★ UFAD systems use an underfloor supply plenum located between the structural concrete slab and a raised floor system to supply conditioned air through floor diffusers directly into the occupied zone of the building.
- ★ Thermal stratification is one of the featured characteristic of UFAD system, which allows higher thermostat setpoints compared to the traditional overhead systems (OH).
- ★ UFAD cooling load profile is different from a traditional OH system due to the impact of raised floor, particularly UFAD may has higher peak cooling load than OH systems.
- ★ UFAD has several potential advantages over traditional overhead systems, including layout flexibility, improved thermal comfort, improved ventilation efficiency, improved energy efficiency in suitable climates and reduced life cycle costs.
- ★ UFAD is often used in office buildings, particularly highly-reconfigurable and open plan offices where raised floors are desirable for cable management.
- ★ UFAD is appropriate for a number of different building types including commercials, schools, churches, airports, museums, libraries etc.
- ★ Careful considerations need to be paid in the construction phase of UFAD systems to ensure a well-sealed plenum to avoid air leakage in UFAD supply plenum.

DISTRIBUTION ABOVE STRUCTURAL FLOOR:

- A raised access floor system allows maximum flexibility in running services because it can accommodate piping, ductwork, and wiring with equal ease.
- It is especially useful in industrial or office areas where large number of computers or computer terminals are used and where frequent wiring changes are likely.
- Through floors can be raised to any desired height above the structural deck, heights of 4 to 8 in. (100 to 200 mm) are most common. Less costly lower profile systems ranging from 2 1/2 to 3 in. (65 to 75 mm) in height are also available

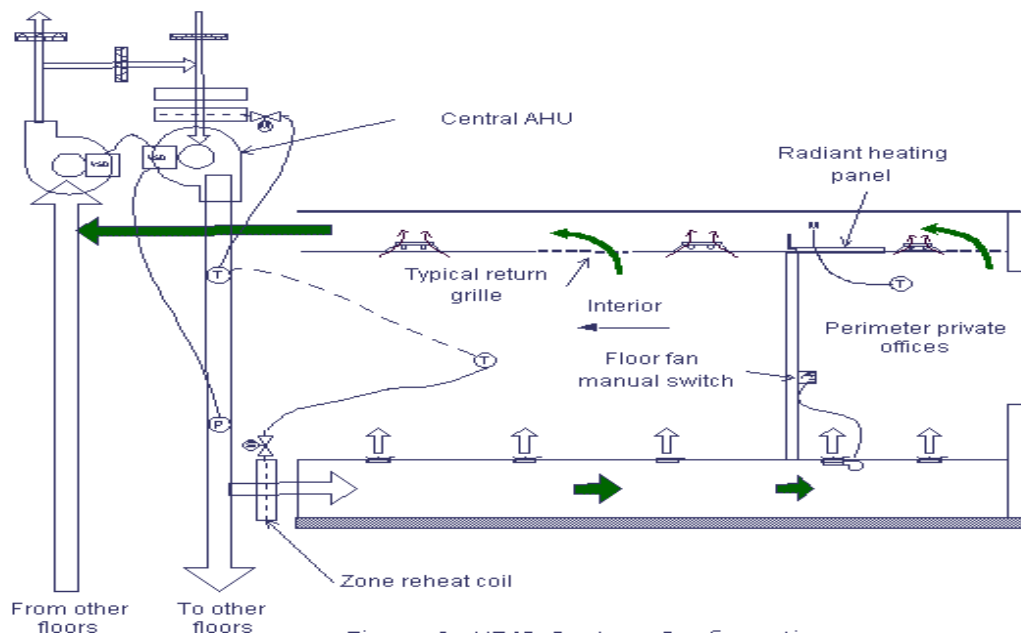
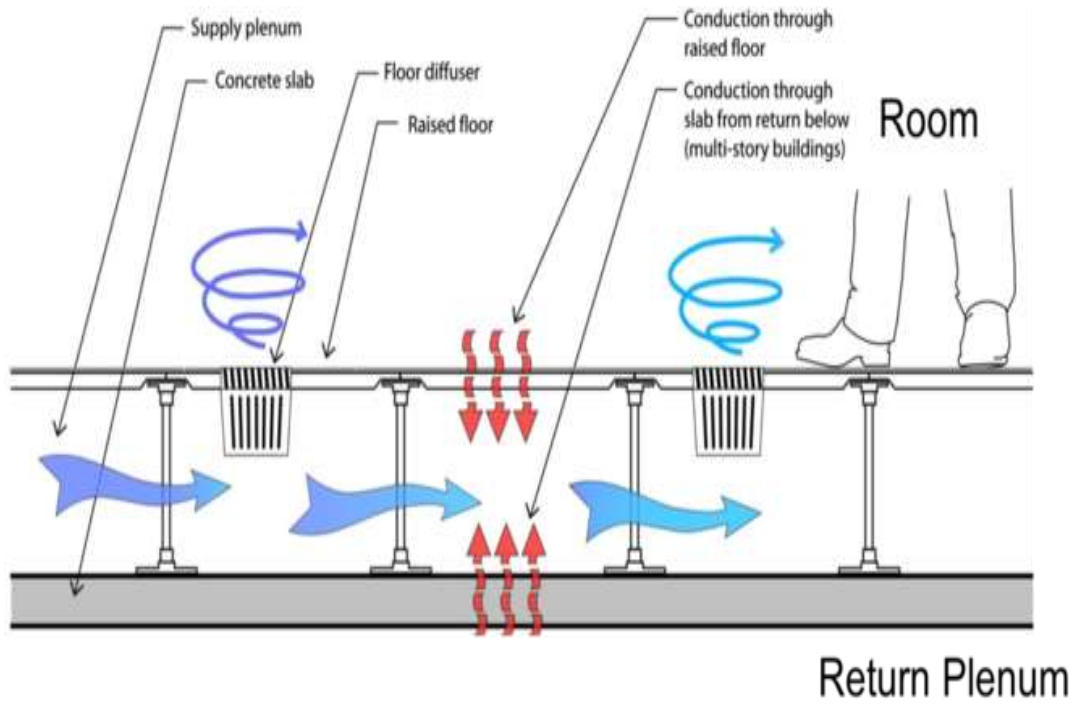

UNIT 3

FIRE AND SAFETY

SYLLABUS

- Causes of fire in buildings.
- Stages of fire and how it spreads.
- Fire drill.
- Heat/ fire/ smoke detection.
- Alarm and extinguisher systems.
- Fire safety standards.
- General guidelines for egress design for multistorey buildings.

3.1 CAUSES OF FIRE IN BUILDINGS

Fire is a chemical process requiring three things to occur: oxygen, fuel and an ignition source. Without one of these factors, a fire can't start or will burn itself out.



Figure: Fire Triangle

- ★ In all chemical processes, molecules rearrange themselves and energy is either absorbed or expelled.
- ★ When a fire burns, a process called oxidation occurs, the same process that causes metal to rust.
- ★ Oxidation is when oxygen atoms combine with carbon and hydrogen to form carbon dioxide and water.
- ★ When metal rusts, the process happens very slowly, but when a fire burns, heat and energy is released very quickly.
- ★ The rate of oxidation is especially fast with fuel sources such as paper and wood. When heat can't release faster than it's created, combustion occurs. This is what creates the flame and heat we call fire.

1. Cooking equipment

Pots and pans can overheat and cause a fire very easily if the person cooking gets distracted and leaves cooking unattended. Always stay in the room, or ask someone to watch your food, when cooking on hotplates.

2. Heating

Keep portable heaters at least one metre away from anything that could easily catch fire such as furniture, curtains, laundry, clothes and even yourself. If you have a furnace, get it inspected once a year to make sure it is working to safety standards.

3. Smoking in bedrooms

Bedrooms are best to be kept off limits for smoking. A cigarette that is not put out properly can cause a flame, as the butt may stay alit for a few hours. It could burst into flames if it came into contact with flammable materials, such as furniture. Did you know that fires started in the bedroom or lounge make up 73% of all house fire fatalities?¹

4. Electrical equipment

An electrical appliance, such as a toaster can start a fire if it is faulty or has a frayed cord. A power point that is overloaded with double adapter plugs can cause a fire from an overuse of electricity. A power point extension cord can also be a fire hazard if not used appropriately. Double check the appliances and power points in your home.

5. Candles

Candles look and smell pretty, but if left unattended they can cause a room to easily burst into flames. Keep candles away from any obviously flammable items such as books and tissue boxes. Always blow a candle out before leaving a room. Did you know that in Perth last year 34 house fires started as a result of candles?²

6. Curious children

Kids can cause a fire out of curiosity, to see what would happen if they set fire to an object. Keep any matches or lighters out of reach of children, to avoid any curiosity turned disaster. Install a smoke alarm in your child's room and practice a home escape plan with your children and family in case there was a fire. Teach kids understand the "stop, drop, cover and roll" drill as well as knowing their address if they needed to call 000.

7. Faulty wiring

Homes with inadequate wiring can cause fires from electrical hazards.

3.2 STAGES OF FIRE

By most standards including the International Fire Service Training Association (IFSTA) there are 4 stages of a fire. These stages are *incipient*, *growth*, *fully developed*, and *decay*. The following is a brief overview of each stage.

Incipient – This first stage begins when heat, oxygen and a fuel source combine and have a chemical reaction resulting in fire. This is also known as “ignition” and is usually represented by a very small fire which often (and hopefully) goes out on its own, before the following stages are reached. Recognizing a fire in this stage provides your best chance at suppression or escape.

Growth – The *growth stage* is where the structures fire load and oxygen are used as fuel for the fire. There are numerous factors affecting the growth stage including where the fire started, what combustibles are near it, ceiling height and the potential for “thermal layering”. It is during this shortest of the 4 stages when a deadly “flashover” can occur; potentially trapping, injuring or killing firefighters.

Fully Developed – When the growth stage has reached its max and all combustible materials have been ignited, a fire is considered *fully developed*. This is the hottest phase of a fire and the most dangerous for anybody trapped within.

Decay – Usually the longest stage of a fire, the *decay stage* is characterized a significant decrease in oxygen or fuel, putting an end to the fire. Two common dangers during this stage are first – the existence of non-flaming combustibles, which can potentially start a new fire if not fully extinguished. Second, there is the danger of a backdraft when oxygen is reintroduced to a volatile, confined space.

How does Fire Spread?

Once started, a building fire is likely to spread until all fuel has been used up. This could have devastating consequences for your home or business. By understanding how fire spreads, you may be better equipped to extinguish it.

- **Chemicals and combustibles:** When fire comes in contact with lab chemicals, household cleaners, paint and other chemicals, the fire burns hotter and more aggressively, encouraging it to spread. Other combustibles commonly found in the home include mattresses, sofa cushions, magazines, newspapers and various textiles.

- **Open space:** A building with limited interior structure burns much faster than one with hallways and closed doors. Walls and doors trap the fire and prevent the flames and smoke from spreading. While the fire will eventually burn through the structure and continue to spread if left to its own devices, a fire fighting team has a much easier time dousing the flames in a building with more walls and doors, especially if those structures are built to withstand the heat and damage of a fire.
- **Construction materials:** While a fire can burn through just about any modern building, fire resistive buildings made of concrete and steel curb the spread of fire better than wood frame homes.
- **Ventilation:** Buildings with central heating or air conditioning have ductwork, which provides a way for flames and smoke to spread between floors of a building, even when the structure is comprised primarily of concrete and steel.
- **Water:** In some cases, water is not the best fire extinguisher. Grease fires, for example, can actually spread faster when doused with water. A special fire extinguisher or baking soda should be used to suffocate and stop the spread of grease fires in the kitchen.

3.3 FIRE DRILL

A **fire drill** is a method of practicing how a building would be evacuated in the event of a fire or other emergencies. In most cases, the building's existing fire alarm system is activated and the building is evacuated by means of the nearest available exit as if an emergency had actually occurred. Fire drill procedures may vary depending on the building type, such as hospitals or high rise buildings, where occupants may simply be relocated within the building as opposed to evacuating the building. Generally, the evacuation is timed to ensure that it is fast enough, and problems with the emergency system or evacuation procedures are identified to be remedied. In addition to fire drills, most buildings have their fire alarm systems checked on a regular basis to ensure that the system is working. Fire alarm tests are often done outside normal business hours so as to minimize disruption of building functions and in schools they are often done during a time when students and staff aren't around or during the holidays where specialist fire alarm engineers will test the alarms in the building and repair or upgrade the system if needed.



Class A

Class A fires are fires in ordinary combustibles such as wood, paper, cloth, rubber, and many plastics.



Class B

Class B fires are fires in flammable liquids such as gasoline, petroleum greases, tars, oils, oil-based paints, solvents, alcohols. Class B fires also include flammable gases such as propane and butane. Class B fires do not include fires involving cooking oils and grease.



Class C

Class C fires are fires involving energized electrical equipment such as computers, servers, motors, transformers, and appliances. Remove the power and the Class C fire becomes one of the other classes of fire.



Class D

Class D fires are fires in combustible metals such as magnesium, titanium, zirconium, sodium, lithium, and potassium.



Class K

Class K fires are fires in cooking oils and greases such as animal and vegetable fats.

3.4 HEAT DETECTORS

A heat detector is a fire alarm device designed to respond when the convected thermal energy of a fire increases the temperature of a heat sensitive element. Heat detectors have two main classifications of operation, “rate-of-rise” and “fixed temperature”. The heat detector is used to help in the reduction of damaged property. It is triggered when temperature increases. **Fixed Temperature Heat Detector** works when the heat exceeds a pre-determined temperature, the bi-metal deflects and closes the contact, triggering the fire signal.

Fixed Temperature Heat / Thermal Detectors can respond to:

- Fixed temperature limit
- Rapid rate of change of the temperature in the protected area
- Combination of these types of detection

Typical fixed temperature spot-type detectors contain a bimetallic switch element that closes at a specified temperature limit. The switch is normally composed of two metals, each having a different temperature coefficient of expansion.

As this bimetallic element heats the metal with higher coefficient of expansion, it causes the switch to bend or curve, closing the switch; thus indicating an alarm condition.

Line type thermal detectors are cables that detect heat along their entire length. A line type thermal detector may consist of two wires that are separated by an insulator.

After the heat builds to a certain level the insulation melts, allowing the wires to touch and current to flow, initiating an alarm.

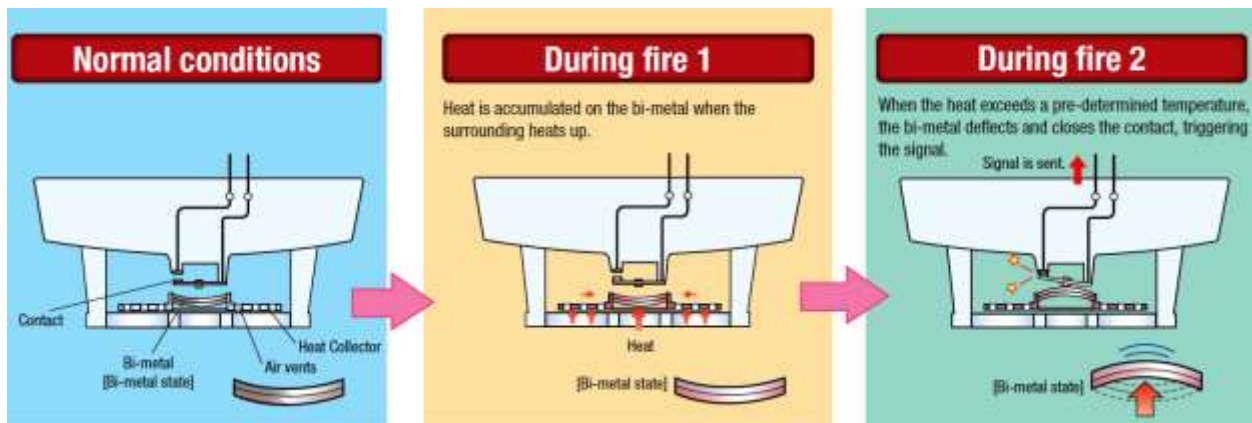

Heat smoke detectors

- This system is concerned with the detection of fire in an area and giving alarming alert to take further action.
- The system generally consists of sensor, alarm and an alerting circuit.
- The main function is to rapidly extinguish the fire which may be due to short circuit or other faults in the equipment.

- The types of sensors used in purely based on the application.

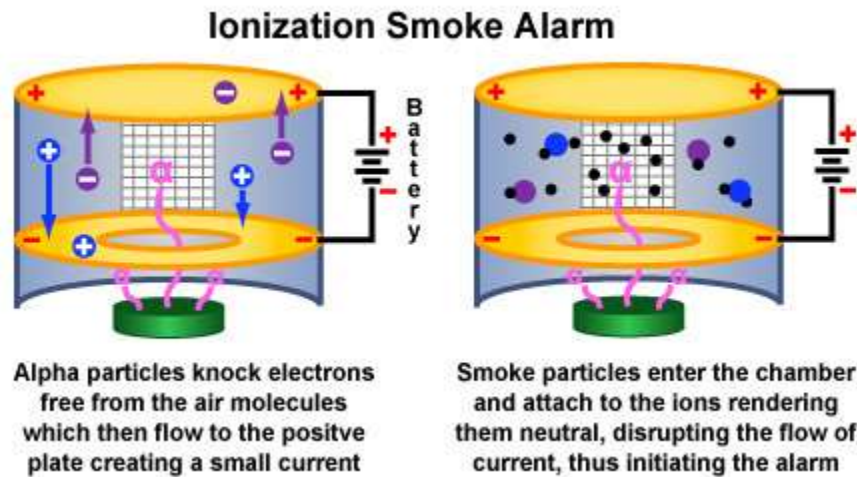

Figure: Shows the ionization smoke detector.

- It consists of a small chamber with a battery connected to two wires. The wires are left separated.
- To make electricity flow from one wire to the other, gap must be closed.
- The chamber contains a radioactive isotope.
- The radioactive isotope charges the air in the gap makes the electric current to flow.
- A current detector detects the current flow and normally the alarm will be quiet.
- If there is a smoke the charged ions in the air gap gets absorbed by the smoke and the current flow gets reduced.
- When the current flow stops the alarm gets operated.
- **Ionization-type smoke alarms have a small amount of radioactive material between two electrically charged plates, which ionizes the air and causes current to flow between the plates. When smoke enters the chamber, it disrupts the flow of ions, thus reducing the flow of current and activating the alarm.**

Photo electric smoke detector:

- The photo electric smoke detector consists of a light source and receiver.
- In normal conditions the light is not received by the sensor.
- When there is high concentration of smoke in the air the smoke particles interrupt the light beam and act like mirrors, reflecting the light so that the light is received by the sensor and it triggers the alarm.

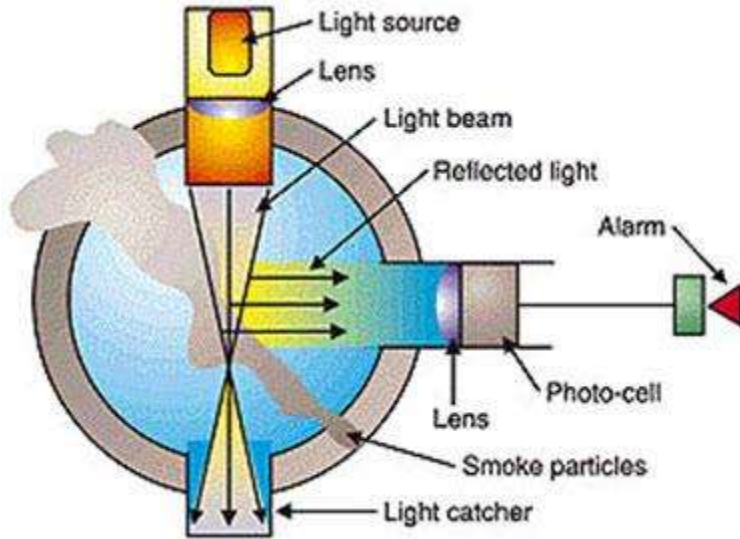

Figure: Photo electric smoke detector

3.5 FIRE ALARM SYSTEM

A fire alarm system has a number of devices working together to detect and warn people through visual and audio appliances when smoke, fire, carbon monoxide or other emergencies are present. These alarms may be activated automatically from smoke detectors, and heat detectors or may also be activated via manual fire alarm activation devices such as manual call points or pull stations. Alarms can be either motorized bells or wall mountable sounders or horns. They can also be speaker strobes which sound an alarm, followed by a voice evacuation message which warns people inside the building not to use the elevators.

- Fire alarm control panel (FACP) OR fire alarm control unit (FACU); This component, the hub of the system, monitors inputs and system integrity, controls outputs and relays information.
- Primary power supply: Commonly the non-switched 120 or 240-volt alternating current source supplied from a commercial power utility. In non-residential applications, a branch circuit is dedicated to the fire alarm system and its constituents. "Dedicated branch circuits" should not be confused with "Individual branch circuits" which supply energy to a single appliance.
- Secondary (backup) power supplies: This component, commonly consisting of sealed lead-acid storage batteries or other emergency sources including generators, is used to supply energy in the event of a primary power failure. The batteries can be either inside the bottom of the panel or inside a separate battery box installed near the panel.
- Initiating devices: These components act as inputs to the fire alarm control unit and are either manually or automatically activated. Examples would be devices such as pull

stations, heat detectors, and smoke detectors. Heat and smoke detectors have different categories of both kinds. Some categories are beam, photoelectric, ionization, aspiration, and duct.

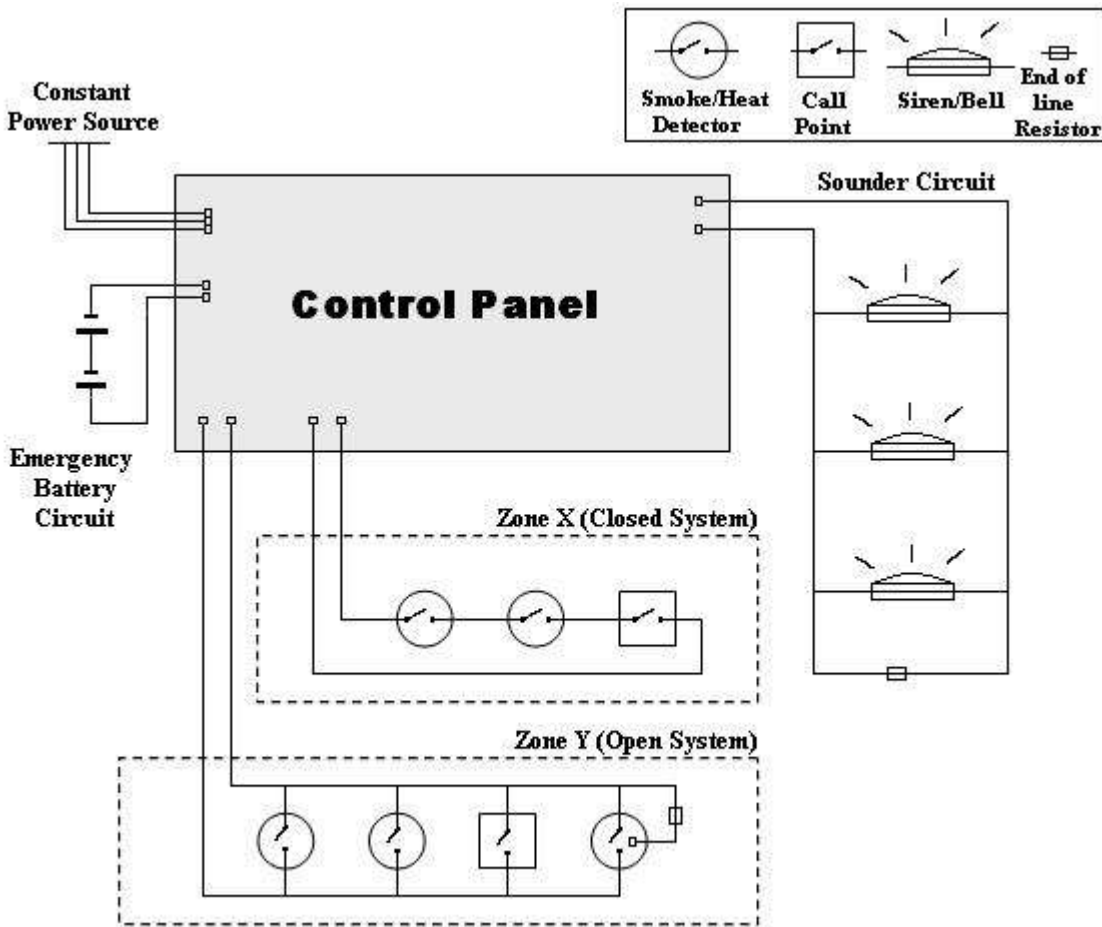

- Notification appliances: This component uses energy supplied from the fire alarm system or other stored energy source, to inform the proximate persons of the need to take action, usually to evacuate. This is done by means of a pulsing incandescent light, flashing strobe light, electromechanical horn, electronic horn, chime, bell, speaker, or a combination of these devices. Strobes are either made of a xenon tube (most common) or recently LEDs.
- Building safety interfaces: This interface allows the fire alarm system to control aspects of the built environment and to prepare the building for fire, and to control the spread of smoke fumes and fire by influencing air movement, lighting, process control, human transport and exit
- Automatic fire detection and alarm systems are designed to warn building occupants of a fire situation, they do not generally intervene in the fire growth process except where interfaced with a fire suppression or other fire control system.

These systems generally use smoke, heat or flame detectors to detect the outbreak of fire and to alert building occupants and the fire service. Manual call points which allow an occupant who discovers fire to raise the alarm may also be included in the system.

Single station residential smoke alarms, as installed in most homes, are the simplest system for detecting a fire and warning the building occupants.

The time between the outbreak of fire and the commencement of firefighting is the single most important factor in fire control and can be effectively reduced by having the system monitored directly by the fire service.

Fire alarm systems must be heard by the building occupants in all parts of the building. To achieve this, they are often connected to occupant evacuation warning and intercommunication systems which sound a defined 'beep - beep - beep' throughout the building when the detection system has been activated.

Sometimes these systems automatically close smoke and fire doors, operate flashing warning lights, stop air-conditioning systems.

Types of Fire Extinguishers



Water and Foam

Water and Foam fire extinguishers extinguish the fire by taking away the **heat** element of the fire triangle. Foam agents also separate the **oxygen** element from the other elements.

Water extinguishers are for Class A fires only - they should not be used on Class B or C fires. The discharge stream could spread the flammable liquid in a Class B fire or could create a shock hazard on a Class C fire.



Carbon Dioxide

Carbon Dioxide fire extinguishers extinguish fire by taking away the **oxygen** element of the fire triangle and also be removing the **heat** with a very cold discharge.

Carbon dioxide can be used on Class B & C fires. They are usually ineffective on Class A fires.



Dry Chemical

Dry Chemical fire extinguishers extinguish the fire primarily by interrupting the **chemical reaction** of the fire triangle.

Today's most widely used type of fire extinguisher is the multipurpose dry chemical that is effective on Class A, B, and C fires. This agent also works by creating a barrier between the **oxygen** element and the **fuel** element on Class A fires.

Ordinary dry chemical is for Class B & C fires only. It is important to use the correct extinguisher for the type of fuel! Using the incorrect agent can allow the fire to re-ignite after apparently being extinguished successfully.



Wet Chemical

Wet Chemical is a new agent that extinguishes the fire by removing the heat of the fire triangle and prevents re-ignition by creating a barrier between the **oxygen** and **fuel** elements.

Wet chemical of Class K extinguishers were developed for modern, high efficiency deep fat fryers in commercial cooking operations. Some may also be used on Class A fires in commercial kitchens.



Clean Agent

Halogenated or **Clean Agent** extinguishers include the halon agents as well as the newer and less ozone depleting halocarbon agents. They extinguish the fire by interrupting the **chemical reaction** and/or **removing heat** from the fire triangle.

Clean agent extinguishers are effective on Class A, B and C fires. Smaller sized handheld extinguishers are not large enough to obtain a 1A rating and may carry only a Class B and C rating.



Dry Powder

Dry Powder extinguishers are similar to dry chemical except that they extinguish the fire by separating the **fuel** from the **oxygen** element or by removing the **heat** element of the fire triangle.

However, dry powder extinguishers are for Class D or combustible metal fires, only. They are ineffective on all other classes of fires.



Water Mist

Water Mist extinguishers are a recent development that extinguish the fire by taking away the **heat** element of the fire triangle. They are an alternative to the clean agent extinguishers where contamination is a concern.

Water mist extinguishers are primarily for Class A fires, although they are safe for use on Class C fires as well.



Cartridge Operated Dry Chemical

Cartridge Operated Dry Chemical fire extinguishers extinguish the fire primarily by interrupting the **chemical reaction** of the fire triangle.

Like the stored pressure dry chemical extinguishers, the multipurpose dry chemical is effective on Class A, B, and C fires. This agent also works by creating a barrier between the oxygen element and the fuel element on Class A fires.

Ordinary dry chemical is for Class B & C fires only. It is important to use the correct extinguisher for the type of fuel! Using the incorrect agent can allow the fire to re-ignite after apparently being extinguished successfully.

Types of Extinguishers:

(a) Portable fire extinguishers can be divided into 5 categories according to the extinguishing agent they contain:

- (i) Water type extinguishers;
- (ii) Foam extinguishers;
- (iii) Dry powder extinguishers;
- (iv) CO₂ extinguishers; and
- (v) Halon / Halon alternative type extinguishers.

(i) Water type extinguishers;

CONSTRUCTION

- These extinguishers are identical in appearance and construction to SODA ACID type of extinguishers.
- The only exception is that instead of acid phial these extinguishers are provided with CO₂ cartridge which is screwed to the cap of the extinguisher.
- The CO₂ cartridge has a sealing disc. The plunger has a piercing type nail attached to it in such a way that it will puncture the sealing disc of CO₂ cartridge when pushed down.

There are two types of this extinguishers based on their position for operation.

- Upright type: These are provided with a dip pipe (siphon tube) attached to the outlet point with or without a discharge hose pipe.

- Invertible type : There is no dip pipe in this type of extinguishers and no discharge pipe is provided

TYPES:

Water (gas cartridge) type extinguisher:

- (i) In this pressure is released from a cartridge which is stored inside the body of the extinguisher. The cartridge is pressurised with CO₂ gas (to a pressure of approx. 35 bars). On puncturing the cartridge, by striking the knob on the top, the gas is released, and on coming out of the cartridge, it expels the water from the body of the extinguisher. The expelled water comes out through the nozzle of the extinguisher in the form of a small jet, which can be projected on to the fire.
- (ii) The liquid capacity of the extinguisher, when filled to the specified level, is 9 litres.
- (iii) The gas cartridge is screwed on to a holder which is fitted on to the cap of the extinguisher. The maximum size of the gas cartridge is 60 g for a 9 litre extinguisher.
- (iv) On operation, the water jet should give an effective throw of not less than 6m for a minimum period of 60 sec., and at least 95 % of water in the extinguisher should be discharged.

Water (Stored Pressure) Extinguisher:

- (i) The extinguisher is filled with water and dry air pressurized up to 10 bars. The air can be supplied by compressed air cylinders or by certain type of pump.
- (ii) Operation is performed by withdrawing the safety pin, depressing the valve lever and directing the water jet by means of the hose.
- (iii) As this type of extinguisher is permanently pressurised, it can only be opened for inspection after discharged.
- (iv) The normal capacity of this extinguisher is also 9 litres.

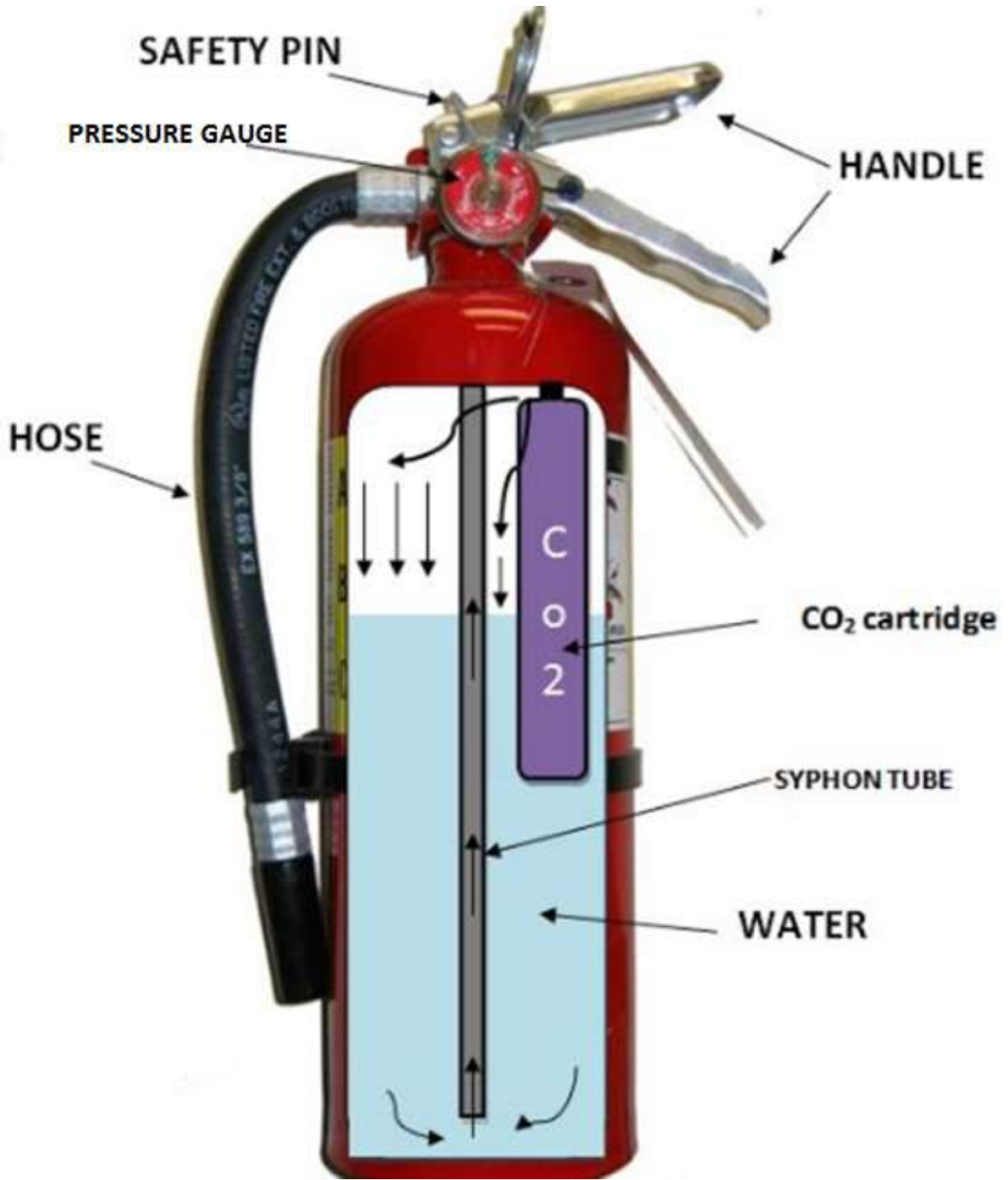

Figure: Water type extinguishers

(ii) DRY CHEMICAL POWDER EXTINGUISHER (Gas Cartridge Type)

The extinguisher is cylindrical in shape, made of solid drawn steel cylinder.

-It has a removable internal shell having gas pores and is protected with thin rubber rings and rubber washer at its neck.

- The extinguisher is fitted with a siphon tube connected to the body with a small length of high pressure flexible hose terminating into a squeeze grip type nozzle attached to its end.

- The nozzle is protected with a rubber cap against entry of moisture.

- The expellant is CO₂ gas in a cartridge which is sealed.

- The CO₂ gas cartridge is screwed to the operating head which is fixed with a piercing mechanism.

- Dry chemical powder is filled in the body in quantities as per capacity.

(i) Various types of dry powder extinguishers are available in the market. Some of them are filled with dry powders suitable for class B & C fires, and some suitable for class A B C fires.

(ii) Dry chemical powders have excellent fire knocking down properties. However, for permanent extinguishment, more often, their use will have to be followed with discharge of extinguishing media like foam or water.

(iii) Dry Powder Extinguisher (stored pressure type): The construction of this type of extinguisher is similar to that of water (stored pressure type). The pressure maintained inside the extinguisher is about 10 bars. It is normally fitted with a pressure gauge and a fan-shaped nozzle.

(iv) Dry Powder Extinguisher (Gas Cartridge) type: 4 sizes of extinguishers of this type are available in the market - 1kg, 2kg, 5kg & 10 kg capacities. The sizes of the gas cartridges also vary according to the extinguisher size. This type of extinguisher is quite common as a requirement for various types of occupancies.

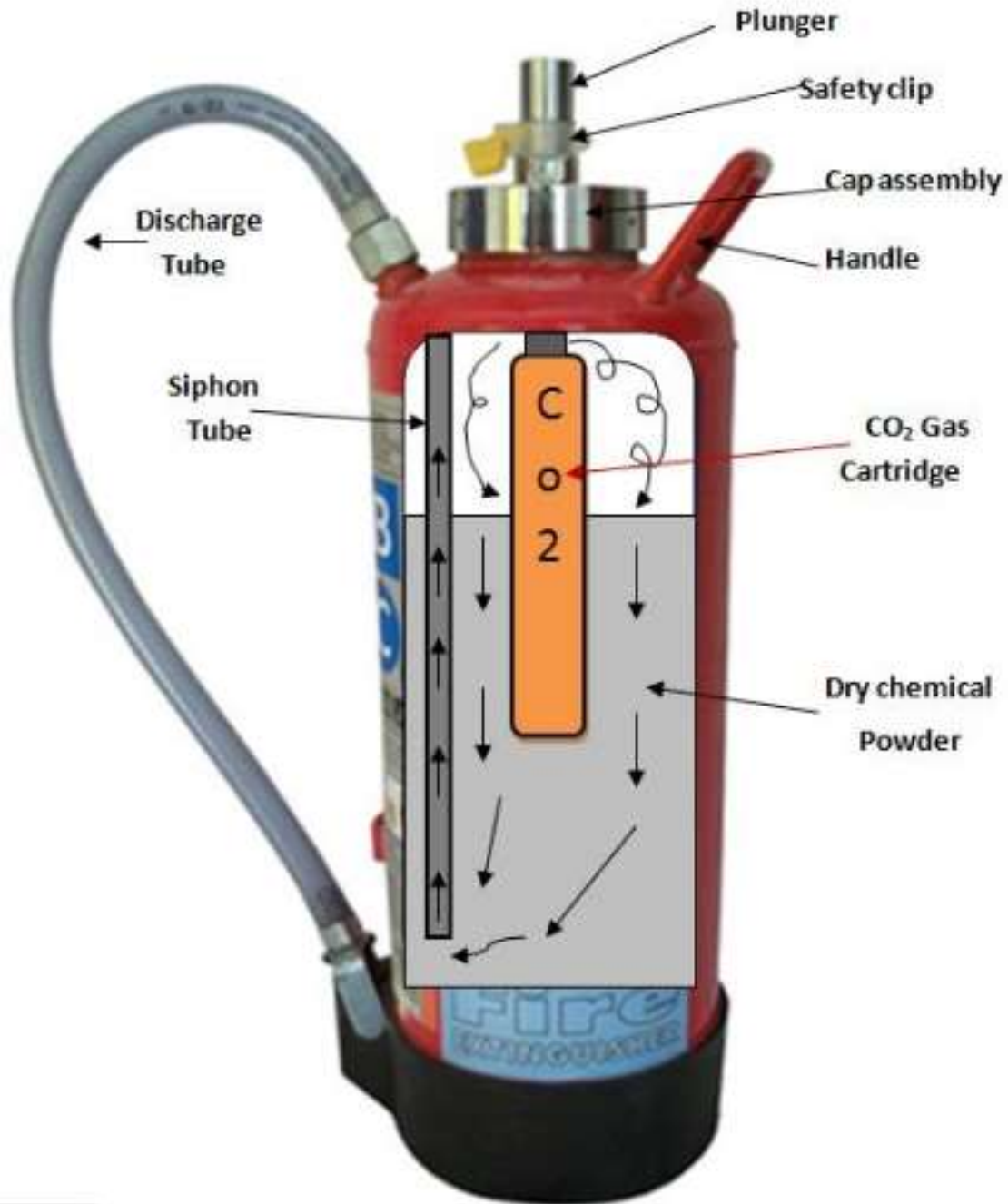

Figure: Dry Chemical powder type fire Extinguisher

(iii) Mechanical Foam extinguisher

The construction of this type of extinguisher is same as that of CO₂ Gas expelled type of water type extinguisher. Instead of water, it contains foam compound mixed in water in the ratio mentioned by the supplier.

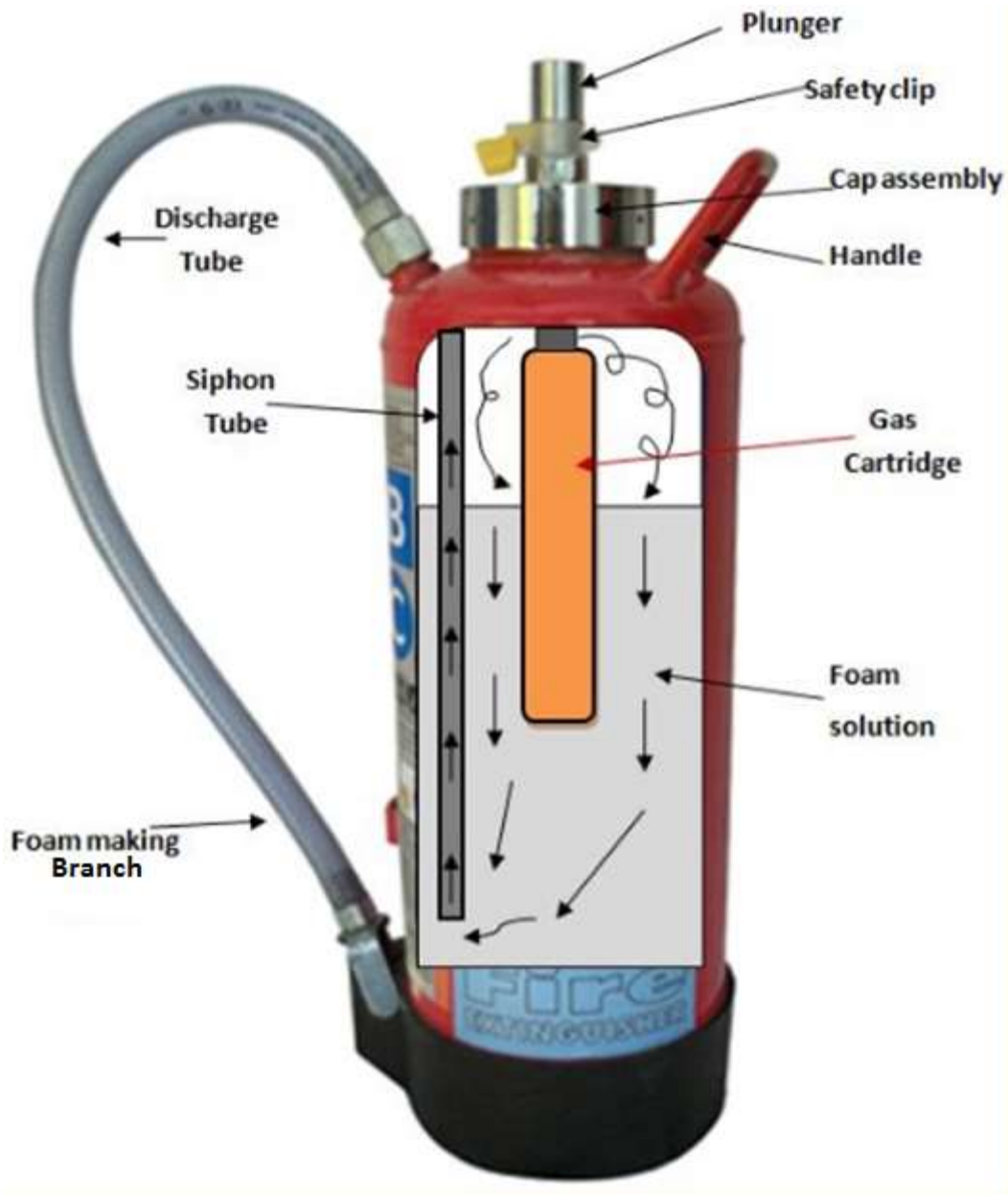

Figure: Mechanical foam fire Extinguisher

Halon Extinguishers:

- In India Halon 1211 extinguishers are still available although they are- getting phased out;
- The standard capacities of these extinguishers are 1.25 kg, 2.5 kg, 4 kg, 5 kg & 6.5 kg;
- They are quite effective on fires in electrical / electronic equipment;

They are getting replaced gradually by other extinguishers containing Halon alternatives

CO₂ AND HALON SYSTEMS

- Carbon Dioxide constitutes a colourless, odorless and inert gas.

- During usage, no damage is provoked (contrary to water or dry powder, the use of which can cause important damage to equipment), it is a safe agent for the majority of materials, non-hazardous for food, non-corrosive and nonconductive.
- It evaporates completely in a few seconds after the extinguishing procedure and leaves no traces.
- Consequently, it can be used with no risk to various spaces containing electrical and electronic devices, precious artworks, paintings or manuscripts, or to flammable liquid warehouses, electric substations, kilns and ovens.
- The use of CO₂ must be avoided to spaces where humans or animals are, because of its provoking suffocating conditions. The three-dimension use of CO₂ means that it can extinguish fires in vertical and horizontal direction.
- Its fast diffusion constitutes the key to a successful extinguishment, since it can penetrate through a break on a wall to all secret and remote places regardless of the obstacles that may exist.
- Carbon Dioxide constitutes a stable commercial product with many other applications and it is widely used all over the world. Permanent CO₂ Systems can be automatically or manually activated, while the activation can be effected mechanically and pneumatically or electronically or from another combination of the above depending on existing conditions.
- Carbon Dioxide is stored in normal temperature conditions in high pressure steel cylinders. Pressure changes depending on the temperature (at 21° C it is about 59bar).

SYSTEM DESCRIPTION

- Single-Cylinder or multi-Cylinder systems can be applied according mainly to the volume of the under protection areas.
- In multi-cylinder systems a Pilot Cylinder is used for activating the rest cylinders of the system.
- The Pilot Cylinder can be activated automatically by use of detonator which gets activated by a Detection System (Smoke & Rate-of-rise Heat Detectors and Control Panel).
- It can also get activated manually by a Remote «System-Activation» Button. The valve of Pilot Cylinder is connected through a High Pressure EPDM Flexible Hose to the valve of the 1st cylinder of the system.
- When the detonator gets activated the valve of the Pilot Cylinder opens and the propellant gas activates pneumatically at first the valve of the 1st cylinder of the system and then the valves of the rest cylinders, which are connected through High Pressure EPDM Flexible Hoses to each other.
- The Carbon Dioxide Gas of the Cylinders of the system is leaded to through High Pressure EPDM Flexible Hoses to the Manifold System.
- The Manifold System consists of Manifold Pipes, Manifold Tee Pieces, Manifold Blind Caps and Non-Return Valves.

- At the end, the Carbon Dioxide Gas passes through the Pipe Network (Red Color SCH40 or SCH80 tubes and 3.000lbs Spare Parts) and heads to the Local or Total Flooding Nozzles from where it is discharged over the under-Protection Area.
- The Detection Equipment consists of Rate-of-rise Heat Detectors and Smoke Detectors, which must be installed in pairs over the under Protection Area.
- A Three-Zone Fire Alarm-Detection Control Panel gets the signal from the detectors incase of fire and an Optical-Sound Siren warns the user that the system will get activated.
- The panel has the essential Time-Delay Option. When the time delay ends, the control panel sends electrical current to the Detonator of the Pilot Cylinder which explodes and the System gets activated.
- In parallel a STOP GAS Security Sign gets activated and warns the user not to enter in the under-Protection Area.

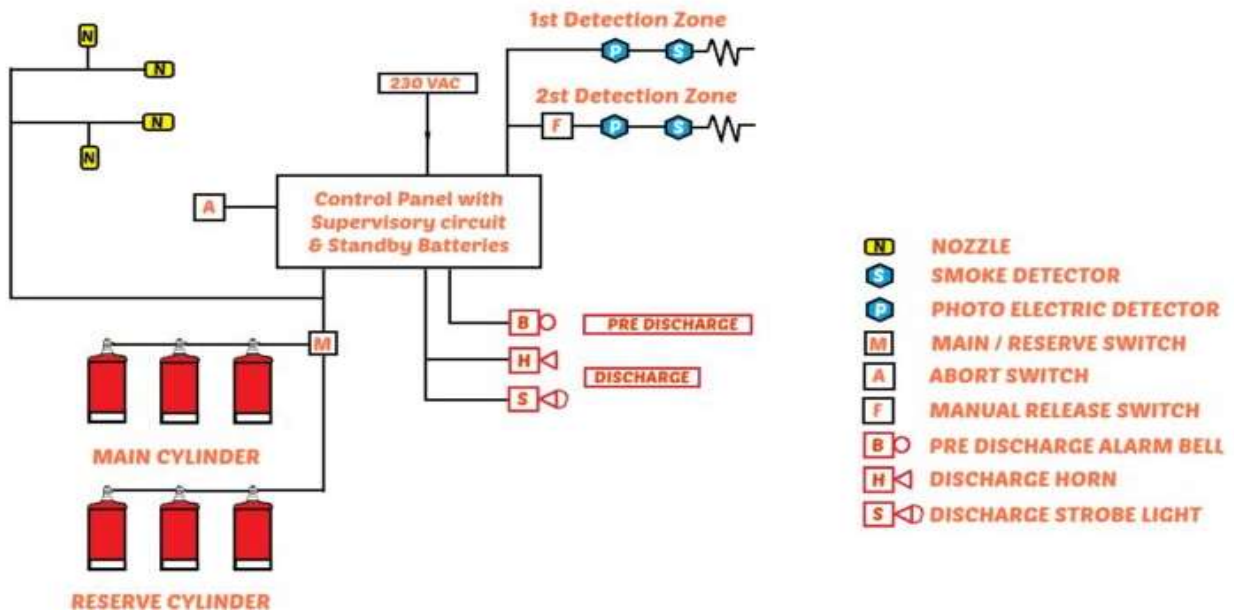

HALON FIRE EXTINGUISHING SYSTEM

HALON

- Halon is a "Clean Agent." The National Fire Protection Association defines, a "Clean Agent" as "an electrically non-conducting, volatile, or gaseous fire extinguishant that does not leave a residue upon evaporation.
- Halon is a liquefied, compressed gas that stops the spread of fire by chemically disrupting combustion. Halon 1211 (a liquid streaming agent) and Halon 1301 (a gaseous flooding agent) leave no residue and are remarkably safe for human exposure.
- Halon is rated for class "B" (flammable liquids) and "C" (electrical fires), but it is also effective on class "A" (common combustibles) fires. Halon 1211 and Halon 1301 are low-toxicity, chemically stable compounds that, as long as they remain contained in cylinders, are easily recyclable.

- Halon is an extraordinarily effective fire extinguishing agent, even at low concentrations.
- According to the Halon Alternative Research Corporation: "Three things must come together at the same time to start a fire.
- The first ingredient is fuel (anything that can burn), the second is oxygen (normal breathing air is ample) and the last is an ignition source (high heat can cause a fire even without a spark or open flame).
- Traditionally, to stop a fire you need to remove one side of the triangle - the ignition, the fuel or the oxygen. Halon adds a fourth dimension to fire fighting - breaking the chain reaction.
- It stops the fuel, the ignition and the oxygen from dancing together by chemically reacting with them."
- A key benefit of Halon, as a clean agent, is its ability to extinguish fire without the production of residues that could damage the assets being protected.
- Halon has been used for fire and explosion protection throughout the 20th century, and remains an integral part of the safety plans in many of today's manufacturing, electronic and aviation companies.
- Halon protects computer and communication rooms throughout the electronics industry; it has numerous military applications on ships, aircraft and tanks and helps ensure safety on all commercial aircraft.
- Because Halon is a CFC, production of new Halon ceased in 1994. There is no cost effective means of safely and effectively disposing of the Halon.
- Therefore, recycling and reusing the existing supply intelligently and responsibly to protect lives and property is the wisest solution.

3.6 FIRE SAFETY STANDARDS

MAXIMUM TRAVEL DISTANCE

GROUP OF OCCUPANCY	MAXIMUM TRAVEL DISTANCE (m)	MAXIMUM TRAVEL DISTANCE (m)
	TYPE 1 & 2 CONSTRUCTION	TYPE 3 & 4 CONSTRUCTION
RESIDENTIAL(A)	30	22.2
EDUCATIONAL(B)	30	22.5
INSTITUTIONAL(C)	30	22.5
ASSEMBLY(D)	30	30
BUSINESS (E)	30	30
MERCANTILE (F)	30	30
INDUSTRIAL (G)	45	30

STORAGE (H)	30	30
HAZARDOUS (J)	22.5	30

DOORWAYS

- No exit doorway shall be less than 1000 mm in width except assembly buildings where door width shall be not less than 2000 mm.
- Doorways shall be not less than 2000 mm in height.

CORRIDORS AND PASSAGEWAYS

- Exit corridors and passageways shall be of width not less than the aggregate required width of exit doorways leading from them in the direction of travel to the exterior

WIDTH OF STAIRCASES

Residential buildings (dwellings) 1.0 m

b) Residential hotel buildings 1.5 m

c) Assembly buildings like auditorium, theatres and cinemas 2.0 m

d) Educational buildings up to 30 m in height 1.5 m

e) Institutional buildings like hospitals 2.0 m

f) All other buildings 1.5 m

WIDTH OF TREAD

- The minimum width of tread without nosing shall be 250 mm for internal staircase of residential buildings.
- This shall be 300 mm for assembly, hotels, educational, institutional, business and other buildings.

RISER

- The maximum height of riser shall be 190 mm for residential buildings and 150 mm for other buildings and the number shall be limited to 15 per flight.
- Handrails shall be provided at a height of 1000 mm to be measured from the base of the middle of the treads to the top of the handrails.

AIR CONDITIONING

- Air -Conditioning systems circulating air to more than one floor area should be provided with dampers designed to close automatically in case of fire and thereby prevent spread of fire or smoke.
- Such a system should also be provided with automatic controls to stop fans in case of fire.
- Escape routes like staircase, common corridors, lift lobbies; etc should not be used as return air passage.

LOCATION OF FIRE DAMPERS

- i) At the fire separation wall.
- ii) Where ducts/passages enter the central vertical shaft.
- iii) Where the ducts pass through floors.
- iv) At the inlet of supply air duct and the return air duct of each compartment on every floor.

The dampers shall operate automatically and shall simultaneously switch off the air-handling fans. Manual operation facilities shall also be provided.

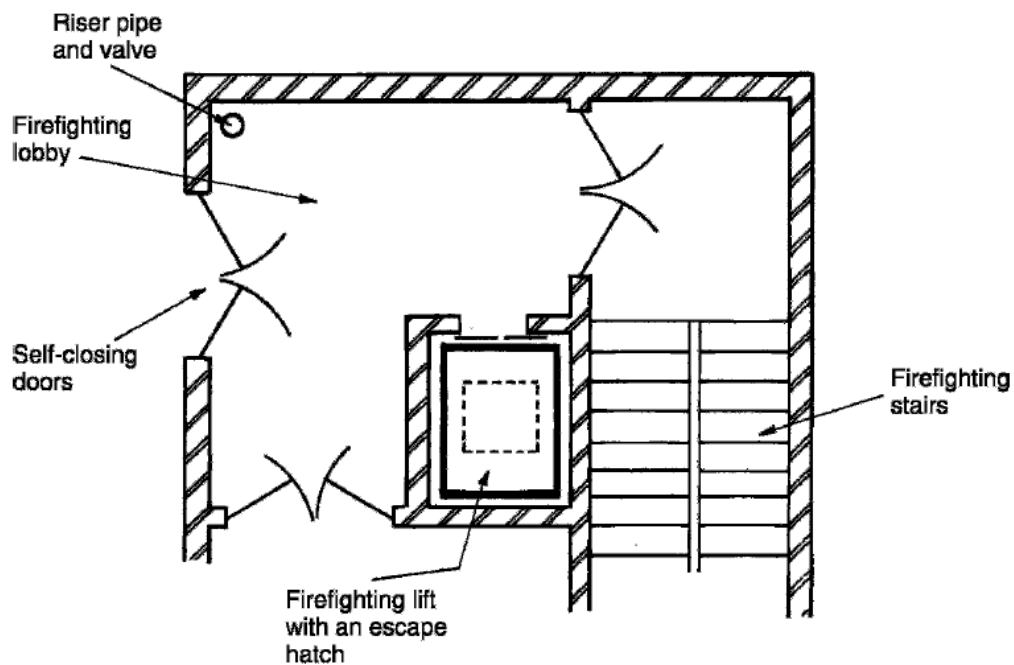

Figure: Fire Lift

- a) To enable fire service personnel to reach the upper floors with the minimum delay, one or more of the lifts shall be so designed so as to be available for the exclusive use of the fireman in an emergency and be directly accessible to every dwelling/lettable floor space on each floor.
- b) The lift shall have a floor area of not less than 1.4 sq.mt. It shall have a loading capacity of not less than 545 kg. (8 persons lift) with automatic closing doors.
- c) The electric supply shall be on a separate service from electric supply mains in a building and the cables run in a route safe from fire that is within a lift shaft. Lights and fans in the elevator having wooden paneling or sheet steel construction shall be operated on 24-volt supply.
- d) In case of failure of normal electric supply, it shall automatically switch over to the alternate supply. For apartment houses, this changeover of supply could be done through manually operated changeover switch. Alternatively, the lift should be so wired that in case of power failure, it comes down at the ground level and comes to stand still with door open.

Lift Enclosure/lift

General requirements shall be as follows

- a) Walls of lift enclosures shall have a fire rating of two hours.
- b) Lift motor room shall be located preferably on top of the shaft and separated from the shaft by the floor of the room.
- c) Landing door in lift enclosures shall have a fire resistance of not less than one hour.
- d) The number of lifts in one lift bank shall not exceed four. A wall of two hours fire rating shall separate individual shafts in a bank.
- e) Lift car door shall have a fire resistance rating of 1 hour.
- f) For buildings 15.0 m. and above in height, collapsible gates shall not be permitted for lifts and solid doors with fire resistance of at least one hour shall be provided.

3.7 EGRESS SYSTEMS

A continuous and unobstructed path of travel from any point in a building or structure to a public way that consists of the following three separate and distinct parts:

- Exit access: The travel path or area that leads from where a person is located to the entrance to an exit.
- Exit: That portion of a means of egress that is separated by construction or equipment from other areas of the building. Exit components include walls, floor, doors, or other means that provide the protected path necessary for the occupants to proceed with

reasonable safety to the exterior of the building. An exit may comprise vertical or horizontal means of travel such as doorways, stairways, ramps, corridors, and passageways. Types of permissible exits are doors leading directly outside or through a protected passageway to the outside, smoke-proof towers, interior and outside stairs, ramps, and escalators in existing buildings. Elevators are not accepted as exits.

- Exit discharge: That portion of a means of egress between the end of the exit and a public way or other safe place.

Arrangement of means of egress

Location

At least two exits should be provided for all areas. These exits must be remotely located from each other and arranged and constructed to minimize the possibility that more than one may be blocked by any one fire or other emergency condition. For all new construction, the “diagonal” rule requires exits to be separated by at least half of the diagonal distance of the area served.

Number of means of egress

The minimum number of exits from any balcony, mezzanine, or other area must be two. The minimum number of exits must be increased as follows:

- Occupant load of more than 49 but fewer than 500
- Occupant load of more than 500 but fewer than 1,000
- Occupant load of more than 1,000
- Exceptions are granted for existing buildings as provided by the specific occupancy sections of various Building or Life Safety codes.

The minimum occupant load or number of people expected in a building at any time is determined by dividing the gross or net floor area of a specific portion of the building by a factor projected for each person. The factor projected for each person and the choice of gross or net floor area varies with the type of occupancy. Specific requirements also exist for fixed seating arrangements. These values are minimums and, if the occupancy level will be higher, then additional existing capacity must be provided. In addition, the exit capacity provided must meet the highest occupancy level expected and should not be designed to an average.

Access to an exit (Maximum Travel Distance)

The codes specify the travel distance allowed to reach an exit. This is an extremely important feature since a person could be exposed to fire or smoke conditions during the time it takes to reach an exit. A general rule is the maximum travel distance to at least one

exit shall not exceed 150 feet in buildings not sprinklered or exceed 200 feet in buildings protected throughout by an approved supervised sprinkler system. Depending on the occupancy, additional limitations on dead-end corridors and common pathways are required in the travel distances to an exit.

Impediments to egress

In no case shall access to an exit be through kitchens, storerooms, restrooms, workrooms, closets, bedrooms, or similar spaces, and exit access doors leading to exits must be designed and arranged to be clearly recognizable. Hangings or draperies should not be placed over exit doors or otherwise located so as to conceal or obscure any exits.

Discharge of an exit

Exits should discharge directly to the outside or equivalent safe area. NFPA highlights circumstances where alternatives such as areas of refuge and exiting through lobby areas can be used.

Means of egress components

Doors, stairs, ramps, and exit passageways are the most common means of egress components. The code also permits fire escape, ladder, alternating tread devices, and slide escapes in certain occupancies. Where safe exiting is not possible, the code also permits “area of refuge” in specific cases.

Egress capacity

Egress capacity for each means of egress component is based on clear width of the component and the type of occupancy. Egress capacity for an exit route is determined by figuring egress capacity for each egress component and determining the most restrictive component in the exit tour. In general, the egress capacity feet factor for stairs is 0.3 inches per person and for ramps and level components is 0.2 inches per person.

Doors

In determining the egress width for a doorway for purposes of calculating capacity, only the clear width of the doorway when the door is in the full open position should be measured. Clear width is the unobstructed width of the door opening.

No door opening in the means of egress should be less than 32 inches clear width opening. This width will allow passage of wheelchairs. For rooms with less than 70 square feet, the width may be reduced to 28 inches provided that wheelchair use is not allowed in the room. For existing structures, the minimum width is 28 inches. The maximum door leaf width is 48 inches to facilitate use in an emergency.

External Corridors

The minimum width of an exit access shall be 36 inches for new buildings and 28 inches for existing. These minimums may be increased by individual occupancy chapter requirements.

Limit displaying combustible wall hangings such as crafts and artwork in school on the corridor walls. The corridor should not be used to store materials and equipment that will restrict its use for safe exiting.

Stairs - dimensional criteria

- ✚ Stairs must be of sufficient width so two persons can descend side by side to maintain a reasonable rate of evacuation. Minimum width clear of all obstructions must be 44 inches.
- ✚ Stair treads must be wide enough to give good footing.. Stair treads must be uniformly slip resistant and must be free of projections or lips that could trip stair users.
- ✚ Landings are required every 12 feet of stair height. Stairs that continue beyond the level of exit discharge must be interrupted at the level of exit discharge by partitions or other effective means.
- ✚ The variance in tread and riser dimensions should not exceed 3/16 of an inch for adjacent treads or risers of 3/8 of an inch from the largest to smallest tread/riser.
- ✚ Handrails should be provided with stairs and shall not be more than 37 inches nor less than 30 inches from the upper surface of the handrail to the surface of the tread, in line with the face of the riser at the forward edge of the tread.
- ✚ New handrails on open sides of stairs must have intermediate rails or an ornamental pattern through, which a sphere of 4-inches in diameter cannot pass.
- ✚ Any means of egress that are more than 30 inches above the floor or grade below must be provided with guards to prevent falls over the open side.
- ✚ Guards must be no less than 42 inches high and new railings should prevent a 4-inch sphere from passing through.

Ramps

- The code permits use of inclined ramps. A new ramp in a public occupancy must have a clear width of 44 inches and typically will have a 1-in-12 slope for a 6-inch or greater rise.
- Steeper but shorter ramps are permitted. Maximum single rise for a ramp is limited to 30 inches.
- The code also requires guards and handrails for ramps. Due to accessibility considerations for the physically challenged, the ramp should be designed with proper slope, width, and slip resistant surfaces.

WINDOW EGRESS

- Although the height of a window above the floor surface can pose a challenge for emergency escape, there is no set maximum sill height for bedroom, windows in the NBC.
- Therefore, it is possible to install a window that satisfies the requirements, but defeats the intent when the sill is so high that it cannot be reached for escape purposes.
- It is recommended that the sills of windows intended for use as emergency escape be not higher than 1.5 m (5 ft) above the floor.
- When it is unavoidable to have a sill height higher than 1.5 m, access to the window should be improved by some means, such as built-in furniture installed below the window.

UNIT 4

MECHANICAL TRANSPORTATION SYSTEMS IN BUILDINGS

SYLLABUS

- Lifts and escalators - types and applications.
- Round trip time for lifts.
- Design of lift lobby and vertical transportation core.
- Conveyors, travelators, dumb waiters. Standards for all.
- Latest technologies in vertical transport systems.
- Integration of lifts and escalators with building automation systems.

LIFTS OR ELEVATORS (TYPES & APPLICATIONS)

- In any multistory commercial or residential buildings, the vertical transportation system typically composed of elevators and escalators.
- The elevators or lift is a type of vertical transport equipment that efficiently moves people or goods between floors of a building.
- Elevators are generally powered by electric motors that drive traction cables or counterweight systems like a hoist or to pump a hydraulic fluid to raise the cylindrical piston in a hydraulic elevator.

Types of elevators:

Elevators used in modern buildings are of four types

- (i) Hydraulic elevators
- (ii) Geared traction elevators
- (iii) Machine room-less traction elevators
- (iv) Gearless traction elevators.

(i) HYDRAULIC ELEVATOR:

- Hydraulic elevators are commonly used in low rise buildings of two to five stories.
- They typically operate at a maximum speed of 150 feet per minute (Fpm)
- Hydraulic elevators are supported by a piston at the bottom of the elevator that pushes the elevator up. The main elevator components are:
 - a. Machine drive system
 - b. Safety system

Machine/ drive system:

- The machine/ drive system consists of piston or plunger. The cylinder shall be constructed of steel pipe of sufficient thickness.
- The top of the cylinder shall be equipped with cylinder head with an internal guide ring and self-adjusting packing.
- The plunger will be welded at the bottom of the cylinder to prevent the plunger from leaving the cylinder.

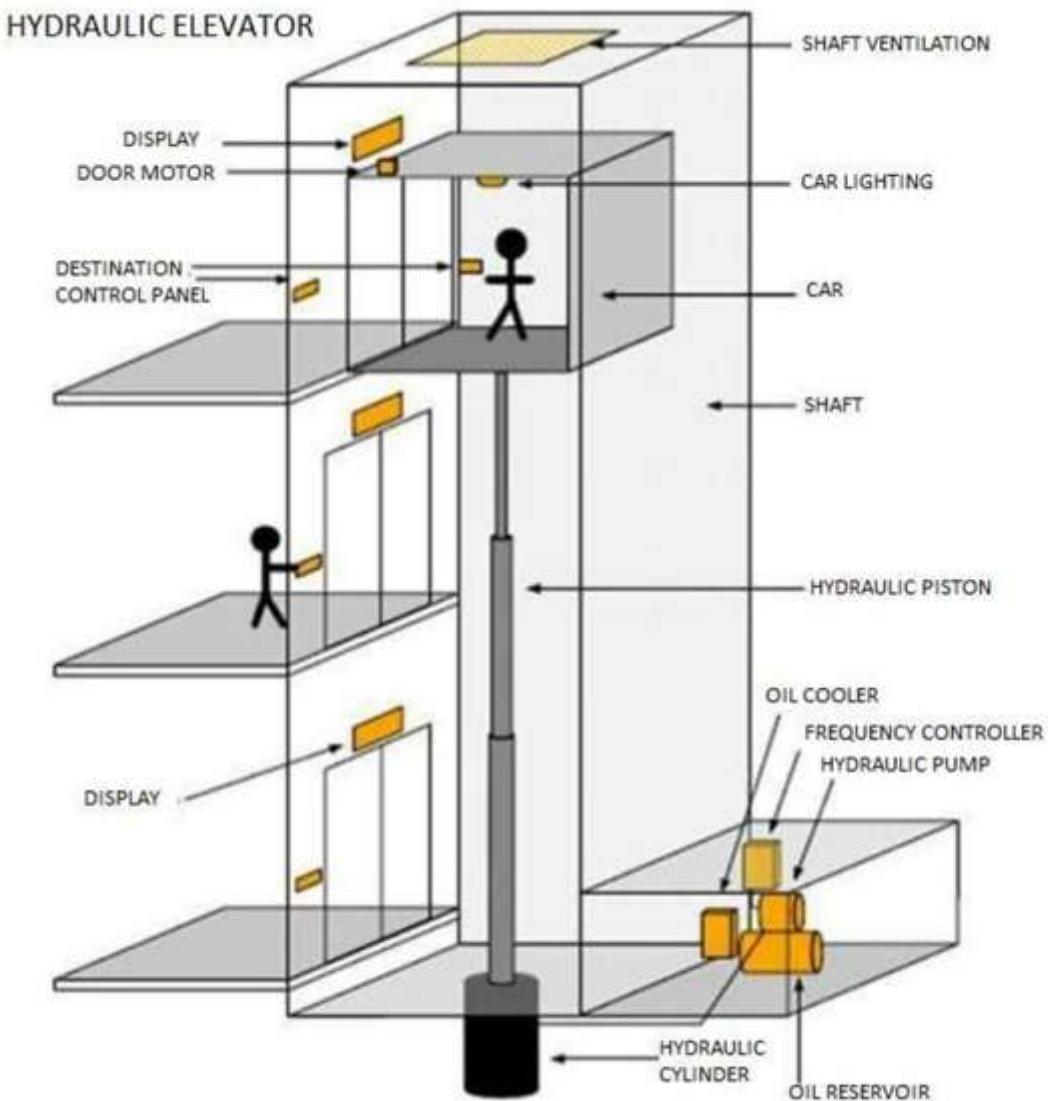

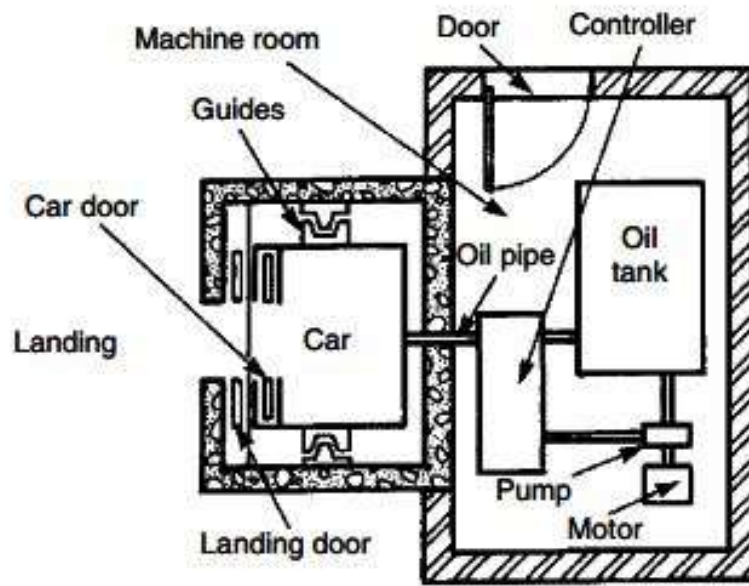

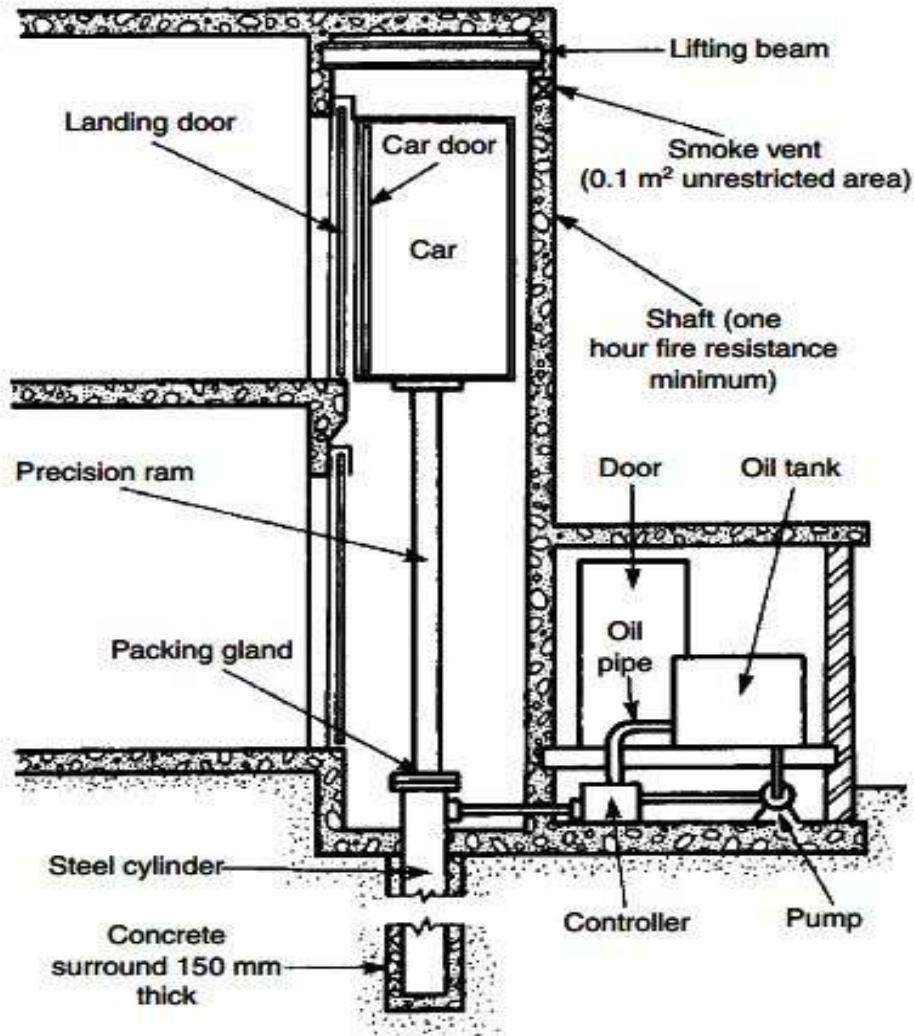

Hydraulic power unit:

The hydraulic power unit consists of:

- ❖ Tank
- ❖ Motor/ pump
- ❖ Valve
- ❖ Actuator
- ❖ Safety system

Tank:

- The tank shall have the sufficient capacity to provide an adequate reserve to prevent the entrance of air or other gas into the system.
- An oil level monitoring device shall be provided for checking the oil level and the minimum oil level mark shall be clearly indicated.
- The main function of the tank is to hold the liquid into the system.

HYDRAULIC ELEVATOR WORKING

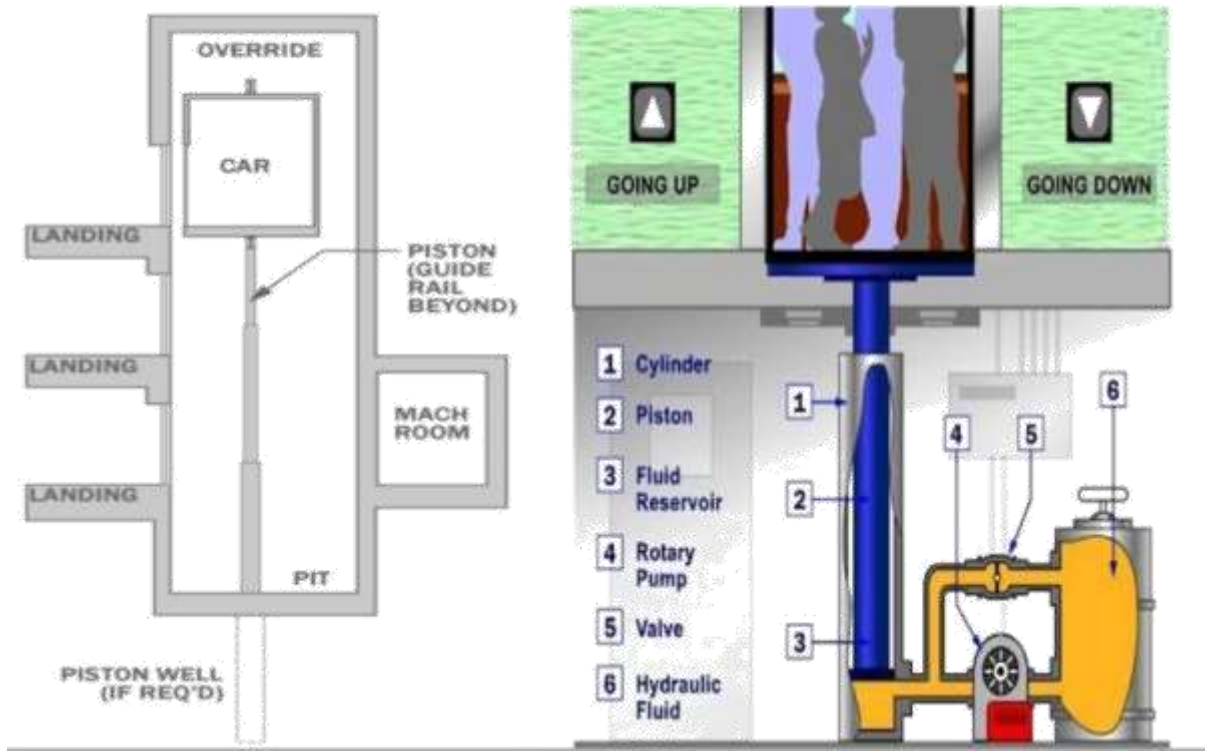

Motor/ pump:

- The main function of the motor/ pump in a hydraulic elevator is to constantly push the liquid into the cylinder to lift the elevator.
- The pump or motor shall be a squirrel cage or slip ring induction motor and it shall run with minimum noise and vibration.

Valve:

The main functions of valve are:

- ❖ Allows the liquid out of tank
- ❖ Keeps the pressure low when open
- ❖ Increases pressure when closed

The valve also has some additional features:

- Up and down acceleration and deceleration speed adjustment.
- Smooth stop at each landing shall be an inherent feature of the valve.

Actuator:

- Actuator is the device that transfers fluid or electrical energy to mechanical energy. The actuator could be a piston because it moved up and down.

Safety system

- The elevator shall be equipped with a final limit switch to cut off all power to the elevator if the upper normal terminal stopping device fails.

MACHINE ROOM LESS TRACTION ELEVATORS:

- Geared traction elevators achieve their vertical motion from shaft. The gear in turn rotates a ring gear been replaced with machine room less elevators.
- Geared traction is used for large capacity service and freight elevators.
- A drive pulley is attached to the ring gear. Steel cables run from the top of the elevator car over the drive pulley to the top of the counterweight.
- As the drive pulley rotates, the elevator car is raised or lowered.
- The passenger elevators that have been provided with a geared traction have now been replaced with machine room less elevators.
- Machine room less traction elevator use compact gearless traction hoist machine that are mounted above the top floor.
- Manually operating 'DOWN' valve to lower elevator in an emergency.

(ii) GEARED TRACTION ELEVATORS:

- Geared traction elevators are used in mid-rise buildings of 5 to 15 stories and typically operate at speeds of 200 to 500 fpm in passenger, service and freight elevator applications.
- Typical speeds are 200 fpm, 350 fpm and 500 fpm.
- The primary difference between a geared traction hoist machine and a compact gearless machine room less traction elevators is that the drive sheave or pulley is directly connected to motor shaft.

(iv) GEARLESS TRACTION ELEVATORS:

- Gearless traction elevators utilizing traditional full size gearless traction hoist machines are used in high rise buildings of 12 to 100 stories and generally operates at the speed of 500 fpm to 18 fpm.
- The drive sheave of gearless hoist machine is directly connected to the motor shaft.
- Faster speeds are possible with traditional gearless elevators because of their large size and they provide optimum performance.

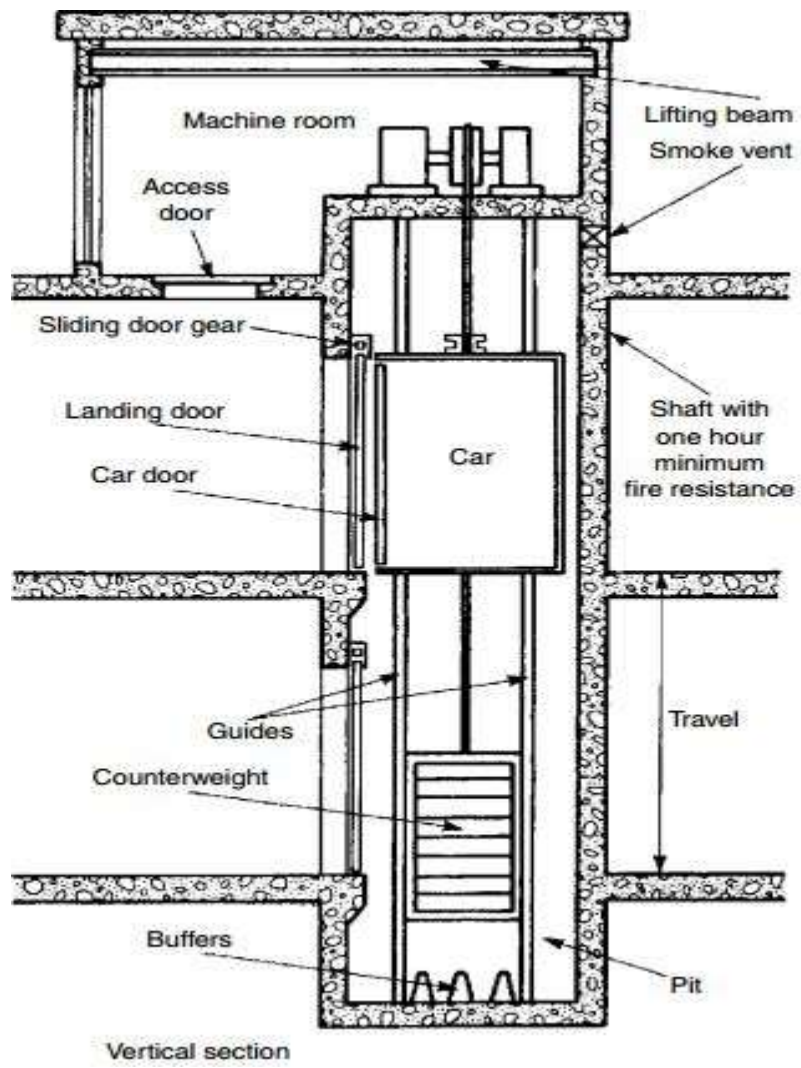
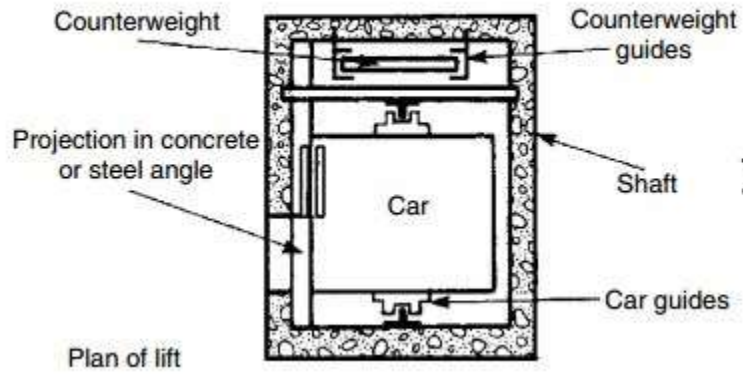

MACHINE ROOMLESS ELEVATOR

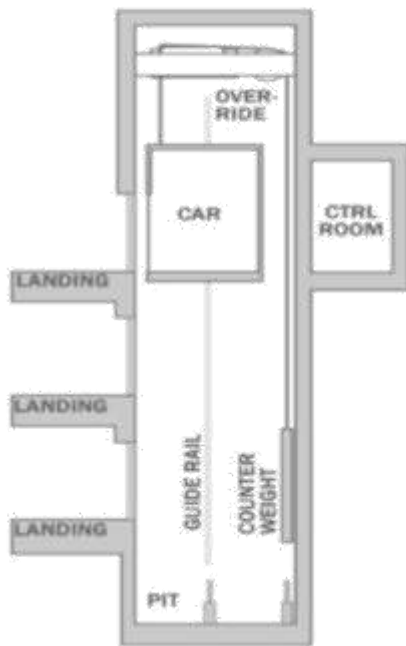

GEARED AND BEARLESS TRACTION ELEVATOR
(WITH MACHINE ROOM)



- **Elevator car** : That part of an elevator that includes the platform, enclosure, car frame, and door.
- **Machine beam** : A steel beam, positioned directly over the elevator in the machine room and is used to support elevator equipment.
- **Machine room** : This usually located at the top of the shaft and accommodates the winding machine, etc.
- **Pit** : That part of an elevator shaft that extends from the threshold level of the lowest landing door down to the floor at the very bottom of the shaft.
- **Shaft** : A hoistway through which one or more elevator cars may travel.
- **Counterweight or balance-weight**. A unit, consisting of steel weights, which counter balance the weight of the car and a portion of the load, and to which the suspension ropes are attached.

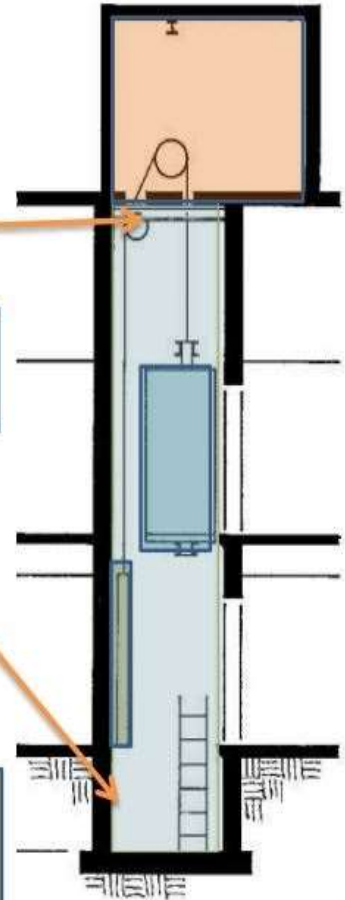

TYPES OF LIFT BASED ON APPLICATIONS:

Passenger Lift: A lift designed for the transport of passengers.

Goods Lift: A lift designed primarily for the transport of goods but which may carry a lift attendant or other person necessary for the unloading and loading of goods.

Service Lift (Dumb-Waiter) : A lift with a car which moves in guides in a vertical direction; has net floor area of 1 m², total inside height of 1.25 m; and capacity not exceeding 250 kg; and is exclusively used for carrying materials and shall not carry any person.

Hospital Lift: A lift normally installed in a hospital/dispensary/clinic and designed to accommodate one number bed/stretcher along its depth, with sufficient space around to carry a minimum of three attendants in addition to the lift operator.

DESIGN CRITERIA OF A LIFT OR ELEVATOR:

- In design of lift there are two basic considerations:
 - The quality of service required
 - The quality of service
- The above two determines the type of lift to be provided in a particular building.
- Quantity of service gives the passenger handling capacity of the lifts during the peak hours.
- Quality of service is measured in terms of waiting time of passengers at various floors.
- The above things can be determined by proper study into the character of the building, duration of peak hours, type and method of control, type of landing doors, tec.

The number of passengers and their capabilities:

- The load and speed for a lift required for a given building depends on the characteristics of the building.
 - a) The number of floor to be served by the lift.
 - b) The population of each floor to be served
 - c) The maximum peak demand.

Population:

- The average population density can vary from one person per 4m² to one person per 20m²
- The population density should be obtained from the building owner.
- If no indication is possible, 5m² per person is normally assumed for office buildings.

QUALITY OF SERVICE:

The quality of service is measured by passage waiting time at the various floors.

Quality of service

- 20-25 seconds – Excellent
- 30-35 seconds – Good
- 35-40 seconds – Fair
- 45 seconds – Poor
- Over 45 sec – Unsatisfied

Note: For residential buildings, longer interval should be permissible

CAPACITY:

- The minimum size of a car recommended for a single purpose building is that it should have a capacity for a duty load of 884kg
- For larger buildings, cars with capacities upto 2040kg are recommended according to the requirement.

SPEED:

- It is dependent upon the quality of service desired. There is no set formula for calculating the speed. The general recommendations are

No. of floors	Speed
4 to 5	0.5 - 0.75 m/s
6 to 12	0.75 - 1.5m/s
13 to 20	Above 1.5 m/s

DETERMINATION OF CAPACITY:

During the morning peak hour,

The handling capacity is calculated by the formula

$$H = \frac{300 \times Q \times 100}{T \times P}$$

Where,

H → Handling capacity as the percentage of the peak population handling during 5 minutes period

Q → Average number of passengers carried in a car

T → Waiting time

P → Total population to be handled during peak morning period

The value of Q depends on the dimensions of the car.

It is noted that the car is not loaded always to its maximum capacity during each tip and therefore for calculating H, the value of Q is taken as 80% of the maximum carrying capacity of the car.

The waiting interval formula is:

$$T = \frac{RTT}{N}$$

N → Number of lifts

RTT → Round Trip Time (it is the average time required by each lift in taking load of passengers from ground floor, discharging them in various upper floors and carrying back to ground floor to take fresh passengers for next trip)

RTT is the sum of the time required in the following process:

- a) Entry of passengers on the ground floor
- b) Exit of the passengers on each floor for discharge
- c) Door closing time on each start operation
- d) Door opening time on each discharging operation
- e) Acceleration periods
- f) Stopping periods
- g) Periods of full rated speeds between stops while going up

h) Periods of full rated speeds between shops while going down.

- The RTT (Round Trip Time) can be decreased by Increasing the speed of the lift
- By improving the design of lift related to opening and closing of the car, acceleration and deceleration also the RTT can be reduced.
- The most important factor is shortening the time consumed between the entry and exit of passengers with proper design of car door width.
- The utilization of centre opening doors also favors the door opening and closing time periods. The centre opening door is much faster than the side opening type.

Lift Pits

- A lift pit shall be provided at the bottom of every lift. Pits shall be maintained in a dry and clean condition. Where necessary, provision shall be made for permanent drainage and where the pit depth exceeds 1.5 m suitable descending arrangement shall be provided to reach the lift pit. And a suitable fixed ladder or other descending facility in the form of permanent brackets grouted in the wall extending to a height of 0.75 m above the lowest floor level shall be provided.
- A light point with a switch shall also be provided for facility of maintenance and repair work.

Machine Room Details

- The lift machine, controller and all other apparatus and equipment of a lift installation, accepting such apparatus and equipment as function in the lift well or other positions, shall be placed in the machine room which shall be adequately lighted and rendered fire-proof and weather-proof.
- The machine room shall have sufficient floor area as well as permit free access to all parts of the machines and equipment located therein for purposes of inspection, maintenance or repair. The room shall be kept closed, except to those who are concerned with the operation and maintenance of the equipment. When the electrical voltage exceeds 220/230 V ac, a danger notice plate shall be displayed permanently on the outside of the door or near the machinery.
- Where standby generator is provided, it is necessary to connect fireman lift to the standby generator. Depending upon the capacity of the standby generator one or more other lifts may also be connected to the supply.
- The height of the machine room shall be sufficient to allow any portion of equipment to be accessible and removable for repair and replacement and shall be not less than 2 m clear from the floor or the platform of machine whichever is higher.

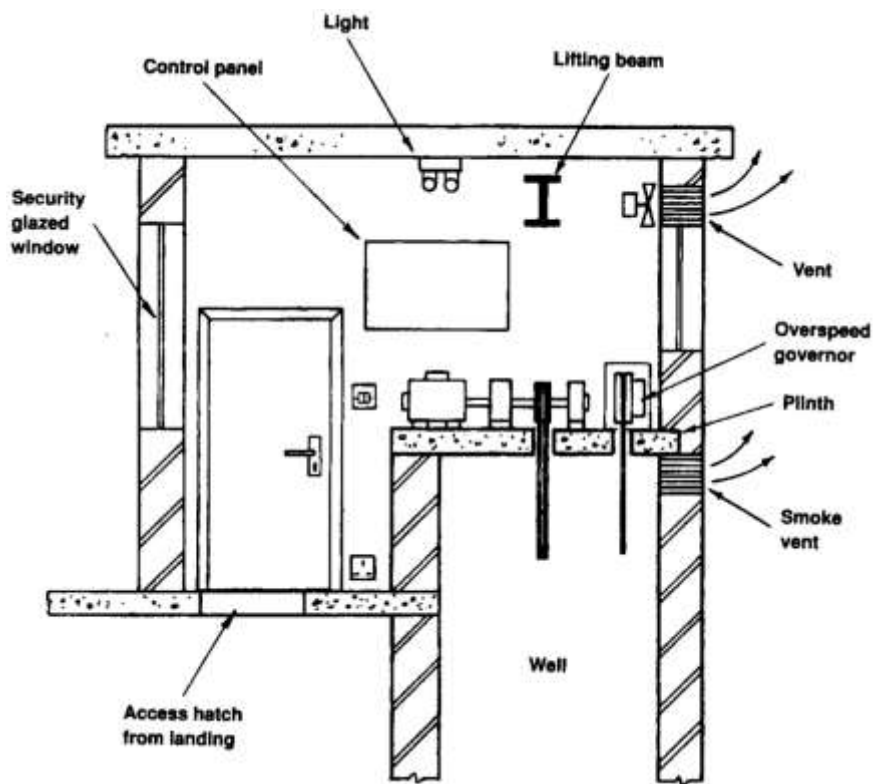
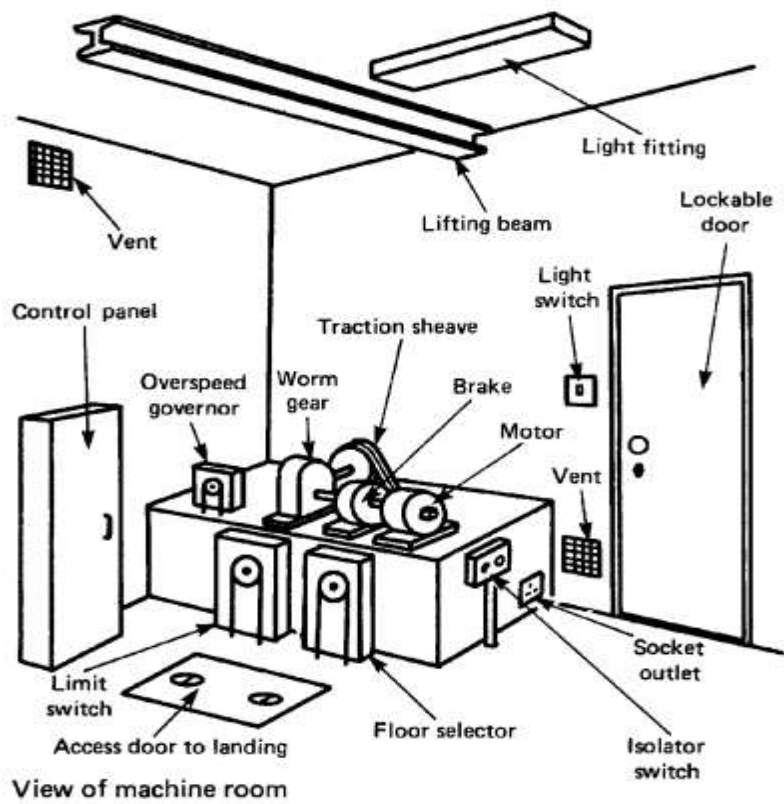

ESCALATORS (TYPES & APPLICATIONS)

Escalators are moving stairs used to convey people between floor levels. They are usually arranged in pairs for opposing directional travel to transport up to 12 000 persons per hour between them. The maximum carrying capacity depends on the step width and conveyor speed. Standard steps widths are 600, 800 and 1000 mm, with speeds of 0.5 and 0.65 m/s. Control gear is less complex than that required for lifts as the motor runs continuously with less load variations.

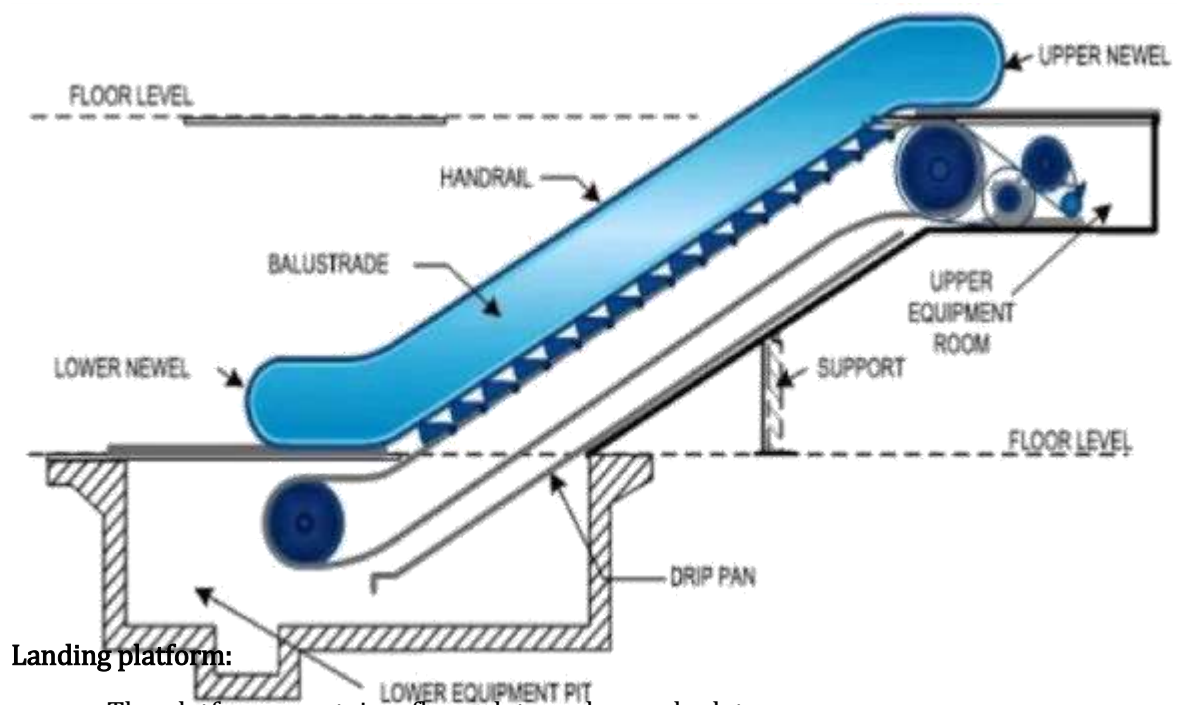

Landing platform:

- The platforms contain a floor plate and a comb plate.
- The floor plate provides space for the passengers to stand before they step on to the moving stairs.
- The comb plate is the space between the stationary floor plate and the moving step. It is so named because its edge has a series of cleats that resemble the teeth of a comb.

Major components of landing platforms are

- a. Comb plate
- b. Access cover
- c. Comb lights

Access cover:

- The access cover is used to access the pit area for inspection, maintenance and repairs, the lower landing access cover plates provide access to the reversing station and step removal.
- The upper landing access cover may provide access to the driving machine and controller.

Comb lights:

- The comb lights are safety devices used to illuminate the area where the steps and comb segments meet.
- They are provided at the upper and lower landing above the comb segments.
- The lights will be on always even if the escalator is not working.

Truss:

- The escalator truss is the structural frame of the escalator. It consists of three sections.
 - a. Lower section
 - b. Inclined section
 - c. Upper section
- It is a hollow metal structure that bridges the lower and upper landings.
- The ends of the trusses are attached to the top and bottom landing platforms through steel or concrete supports.
- The front and back edges of the steps are each connected to two wheels.
- The rear (back) wheels are set further apart to fit into the back track and front wheels have shorter axles to fit into the narrow front track.

Handrail:

- The handrail provides a convenient handhold for the passengers while they are riding on the escalator.

Balustrade:

- The balustrade consists of the handrail and the exterior supporting structure of the escalator.
- It is the escalator exterior components extending above the step and it supports the handrail.

Steps:

- The steps are made of aluminium or steel.
- The steps are linked by a continuous metal chain that forms a closed loop.

Tracks:

- The track system is built into the truss to guide the step chain, which continuously pulls the steps from the bottom platform and books to the top in an endless loop
- There are actually two tracks:
 - a) One for the front wheel of the steps
 - b) One for the back wheel of the steps
- The track assembly is bolted but not welded on the truss for easy removal.
- The tracks are used to guide step wheels and step chains in their travel around the escalator truss.

Newel:

- Newel is the balustrade termination at the upper and lower landing of the escalator in a semi-circle shape.
- It contains the following switches.
 - a. Emergency stop
 - b. On / Off
 - c. Up / down directional indicator lighting

Emergency stop button:

- Emergency stop button is located at the newel so that anyone can stop the escalator if there is a need.
- When the button is pressed, power to the electrical drive motor is shutoff and the escalator brake is applied.

Key operated switches:

- Located on each newel and they are used to control the “ON” and “OFF” operation and the direction of escalator travels.

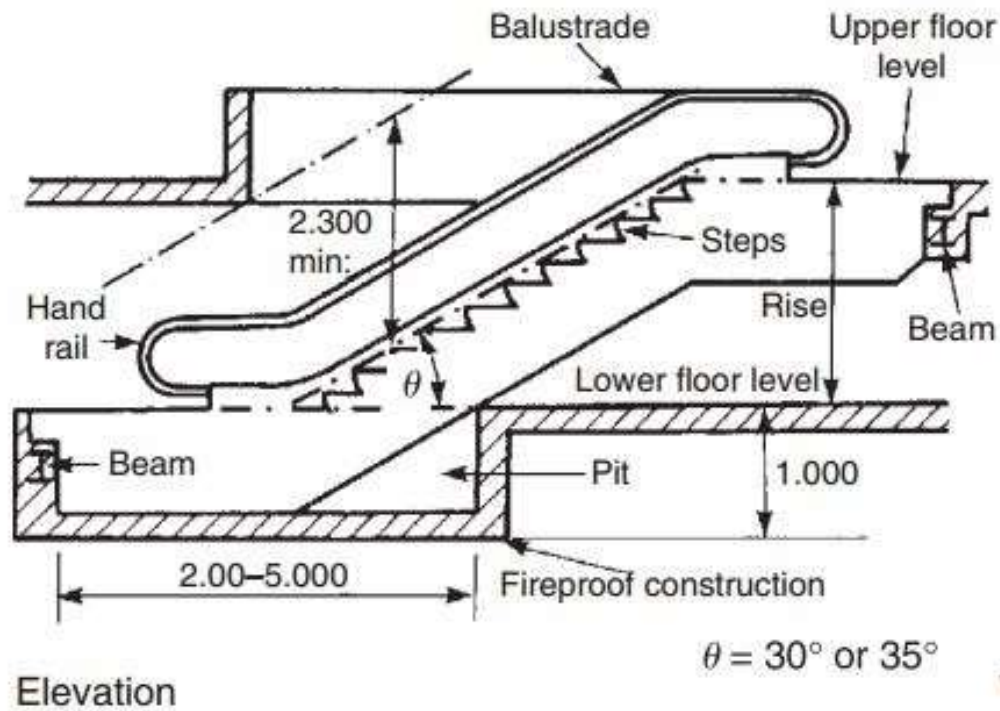

TYPES OF ESCALATORS

Escalator arrangements or configuration of escalators:

1. Single unit:

The single unit is used to connect two levels. It is suitable for buildings with passenger traffic flow mainly in one direction. Flexible adjustment to traffic flow.

Example: Upward direction in the morning and downward direction in the evening is



possible.

2. Double unit:

This arrangement is used in the places in which persons travel in two opposite directions.



3.
Criss
ross

arrangement (Two way traffic)

- This type of installation is the one used more frequently as it allows customer to travel quickly to the upper floors without any waiting time.
- Commonly used in big departmental stores and office buildings.

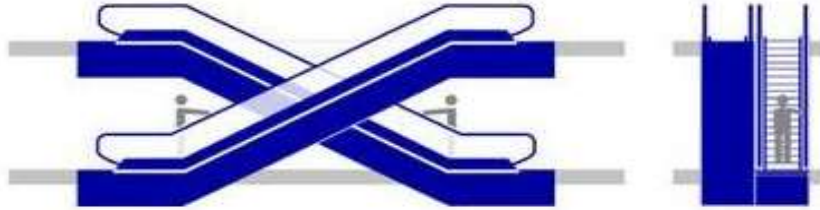

4. Single unit continuous (One way traffic)

The escalator that connects subsequent levels in one-way traffic is used mainly in small department stores and commercial buildings.

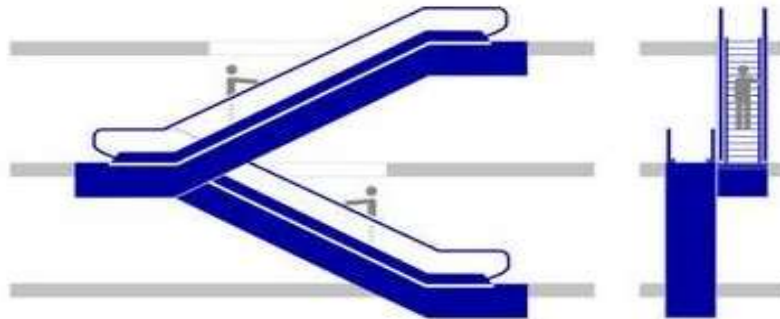

5. Single unit non-continuous (One way traffic)

- ★ The escalator that connects subsequent levels in a non-continuous one-way traffic is not too comfortable for persons who want travel quickly through subsequent floors.
- ★ However, this operation arrangement is attractive for owners of department stores because it encourages visiting around. The escalator is used mainly in small departmental stores and in commercial centres.

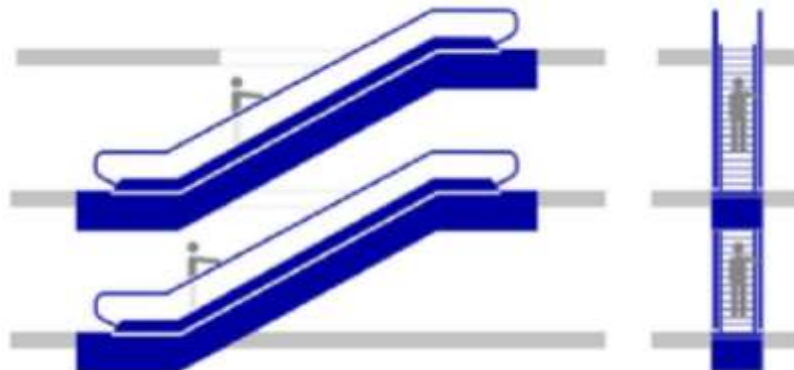

Parallel arrangement:

- This arrangement is mainly used in departmental stores and public buildings with heavy traffic.
- When there are three or more escalators or moving walks, it should be possible to reverse the direction of travel depending on traffic flow.

6. Double non-continuous (Two way traffic)

- The escalator that connects subsequent levels in a non-continuous two way traffic is used in office buildings and public transport buildings.
- The direction can be changed depending on the time.

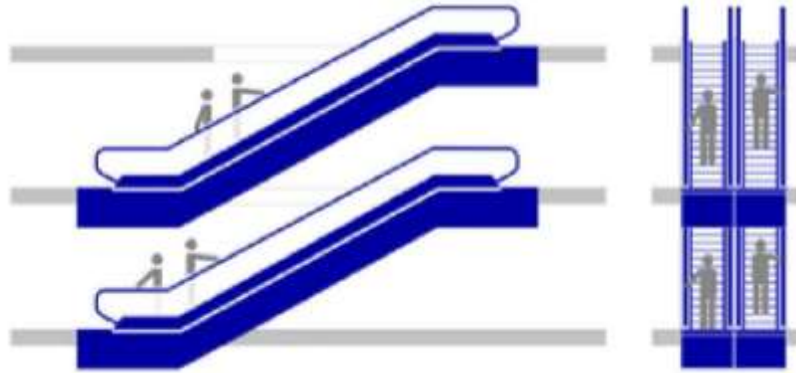

7. Crisscross arrangement (Two way traffic)

This arrangement is used mainly in big department stores, office buildings and public transport where efficient travel of person between floors is of high importance.

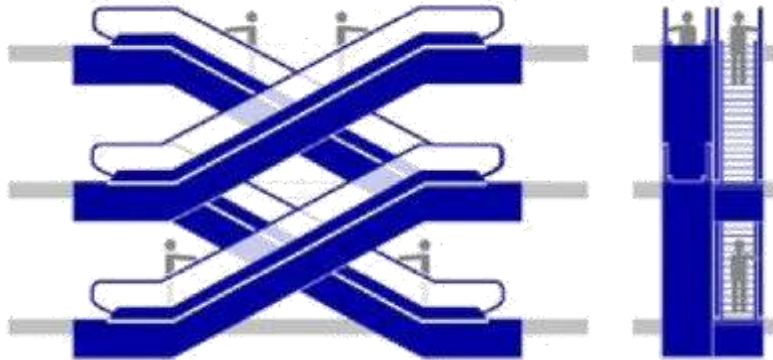

ESCALATORS AND HORIZONTAL MOVING WALKWAYS (DESIGN):

- (i) An escalator is a moving staircase – a conveyor transport device for carrying people between floors of a building.

- (ii) Escalators are powered by constant speed AC motors and more approximately at a speed of (0.30 – 0.65 m) per second
- (iii) Modern escalators have steel steps that move on a system of tracks in a continuous loop.
- (iv) Direction of movement up or down can be permanently the same or be controlled by personnel according to the time of the day.

Benefits of escalators:

- (i) They have the capacity to move large number of people.
- (ii) They have no waiting interval
- (iii) They can help in controlling traffic flow of people.
- (iv) They can be weather proofed for outdoor use.

INCLINATION OF ESCALATORS AND MOVING WALKWAYS:

Escalators	Moving walkways
<ul style="list-style-type: none"> • Inclination of 30° and 35° are the common international standards for escalators • 30° inclination: This inclination provides the highest travelling comfort and maximum safety for the user. • 35° inclination: The 35° inclination is the most efficient solution as it requires less space and can be implemented more cost effectively 	<ul style="list-style-type: none"> • Inclination of 10°, 11°, 12° are the common international standards for inclined moving walkways • 10° inclination provides the most comfortable ride. • Horizontal moving walkways can generally be provided for inclinations between 0° and 6°

Escalator capacity:

- Most escalators are designed with 1000mm wide steps which allows passengers to move comfortably when carrying luggage and shopping bags.
- 600mm and 800mm wide are also available and generally used in low traffic areas.
- Speed ranges between 0.5 to 0.65 m/s
- For a speed of 0.5 m/s the theoretical capacity is
 - 600mm step width – 4500 persons/ hour
 - 800mm step width – 6750 persons/ hour
 - 1000mm step width – 9000 persons/ hour

The following formula can be used to calculate the capacity,

$$N = \frac{3600 \times P \times V \times \cos \theta}{L}$$

Where, N → Number of persons moved/ hour

P → Number of persons/ step

- V → Escalator speed (m/s)
- L → Length of step (m)
- θ → Angle of inclination

Example:

An escalator of 30° incline, one passenger/ step, a speed of 0.5 m/s and 400mm step length

$$N = \frac{3600 \times 1 \times 0.5 \times \cos 30^\circ}{0.4}$$

$$= 3897 \text{ number of persons moved per hour}$$

MOVING WALKWAYS (step width)

- For inclined moving walkway (10° to 12°) pallets are available in width of 800 and 1000mm
- The most popular width is 1000mm. the moving walkways with this pallet width are also suitable for transporting, shopping. They are mainly used in shopping centres and railway stations.
- For horizontal moving walks with an inclination of (0° to 6°) pallets are available in width of 800mm, 1000mm, 1200mm and 1400mm.
- In airports, 1200 or 1400mm wide moving walks are to be installed in a continuous arrangement. The same step and pallet width should be selected for all units.

OPTIMAL SPEED FOR ESCALATORS AND MOVING WALKWAYS:

The speed not only has a considerable impact on the potential transportation capacity of escalators and moving walkways but also it influences the space requirements.

0.5 m/s	0.6 m/s	0.75 m/s
<ul style="list-style-type: none"> • This is the standard speed of escalator and moving walkways in commercial sector. • Safety, minimum space requirement makes this speed the worldwide standards. 	<ul style="list-style-type: none"> • Used in railway stations • Longer horizontal runs are required to ensure safety of the escalator/ moving walkways. 	<ul style="list-style-type: none"> • Although speeds upto 0.75 m/s (escalators) and upto 0.9 m/s (moving walkways) are possible, there is increased danger of children or elder people falling in the landing area

Transportation of disabled persons and baby carriages:

- Escalators and moving walkways are not suitable for transporting wheel chairs and baby carriages.
- It is recommended to post an alert near the escalator and moving walkways.

Free space:

- To ensure safety use of the escalators and moving walkways, sufficiently larger free spaces must be provided at the upper and lower landings.
- For moving walkways the free spaces should have a length of atleast 5m.

Balustrade height:

- Balustrades are available in heights of 900, 1000 and 1100mm. the advantage of 900mm balustrade is that even small children can easily reach the handrail.
- For greater fall heights balustrade with a continuous height of 1000mm is recommended.

Overhead clearance:

- The free overhead clearance at every point along the step/ pallet must be atleast 2.3m.

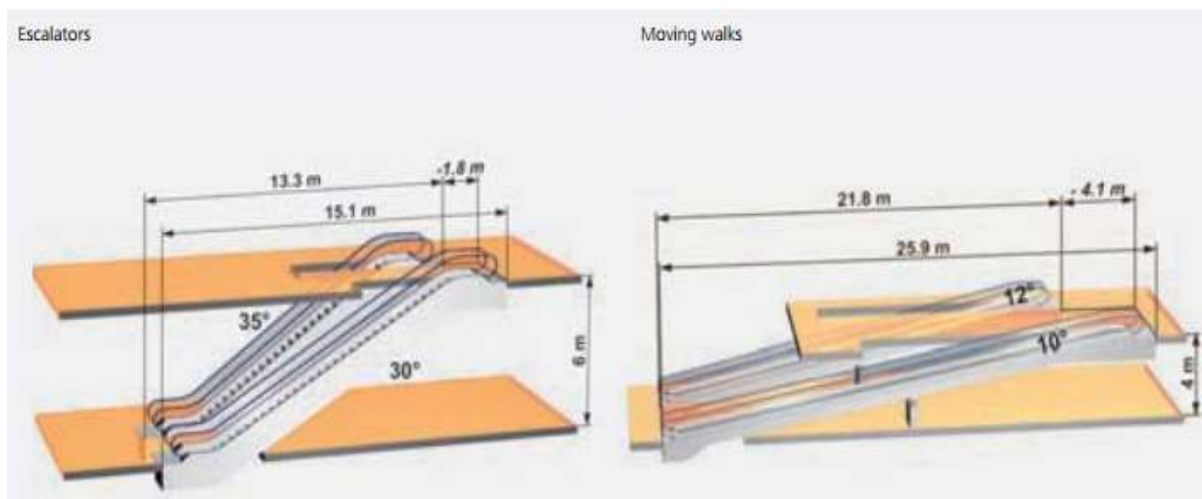

MOVING WALKWAYS OR TRAVELATORS

Travelators also known as autowalks, passenger conveyors and moving pavements. They provide horizontal conveyance for people, luggage trolleys, wheelchairs and small vehicles for distances up to about 300 metres. Slight inclines of up to 12 degree are also possible. Applications range from retail, commercial and store environments to exhibition centres, railway and airport terminals. Speeds range between 0.5 and 0.75 m/s, any faster would prove difficult for entry and exit.

A slow moving conveyor mechanism that transports people across a horizontal or inclined plane over a short to medium distance.

- can be used by standing or walking on them. They are often installed in pairs, one for each direction.
- are built in one of two basic styles:

Pallet type — a continuous series of flat metal plates join together to form a walkway. Most have a metal surface.

Moving belt — these are generally built with mesh metal belts or rubber walking surfaces over metal rollers.

High speed walkways

- Using the high-speed walkway is like using any other moving walkway, except that for safety there are special procedures to follow when joining or leaving.
- riders must have at least one hand free to hold the handrail, those carrying bags, shopping, etc., or must use the ordinary walkway nearby.
- Riders stand still with both feet on the metal rollers and let it pull them so that they glide over the rollers.

Inclined moving walkways

- is used to move people to another floor so that people can take along their suitcase trolley or shopping cart, or baby carriage.
- The carts have either a brake that is automatically applied, strong magnets in the wheels to stay adhered to the floor, or specially designed wheels that secure the cart within the grooves of the ramp, so that wheeled items travel alongside the riders and do not slip away.

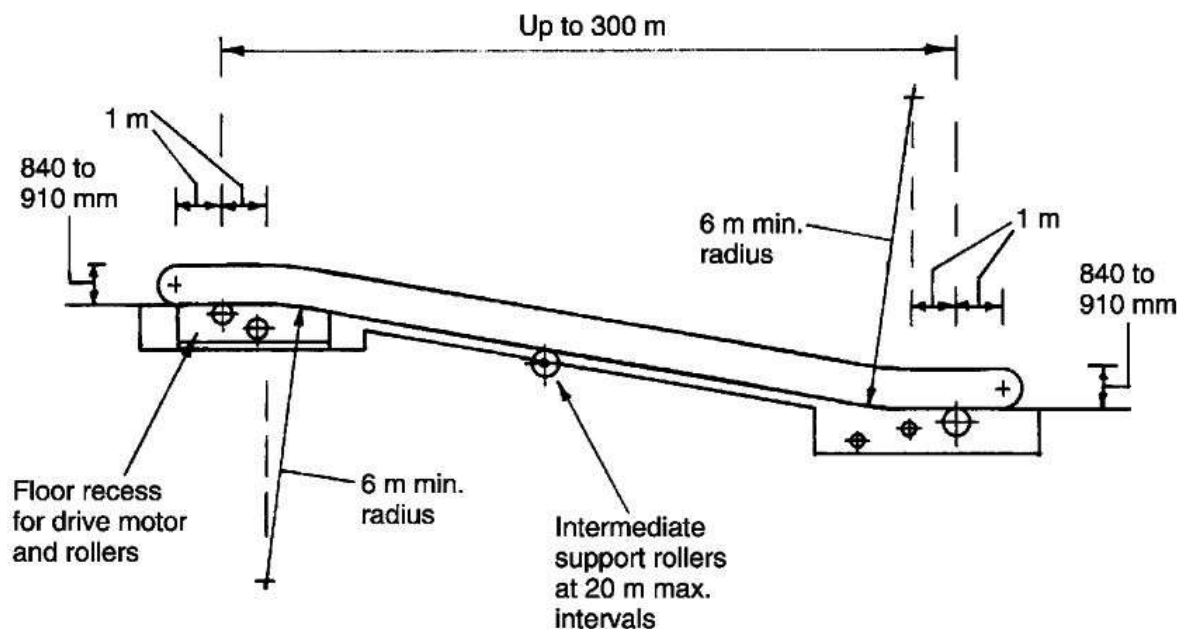

Detailing for comfort, convenience of users

- Directional indication of location of the lift lobby for people unfamiliar with the building.
- Call buttons at landings and in the car positioned for ease of use with unambiguous definition for up and down directions.
- Call buttons to be at a level appropriate for use by people with disabilities and small children.
- Call display/car location display at landings to be favorably positioned for a group of people to watch the position of all cars and for them to move efficiently to the first car arriving.

- Call lights and indicators with an audible facility to show which car is first available and in which direction it is travelling.
- Lobby space of sufficient area to avoid congestion by lift users and general pedestrian traffic in the vicinity.

ROUND TRIP TIME FOR LIFTS

RTT → Round Trip Time (it is the average time required by each lift in taking load of passengers from ground floor, discharging them in various upper floors and carrying back to ground floor to take fresh passengers for next trip)

RTT is the sum of the time required in the following process:

- i) Entry of passengers on the ground floor
 - j) Exit of the passengers on each floor for discharge
 - k) Door closing time on each start operation
 - l) Door opening time on each discharging operation
 - m) Acceleration periods
 - n) Stopping periods
 - o) Periods of full rated speeds between stops while going up
 - p) Periods of full rated speeds between stops while going down.
- The RTT (Round Trip Time) can be decreased by Increasing the speed of the lift
 - By improving the design of lift related to opening and closing of the car, acceleration and deceleration also the RTT can be reduced.
 - The most important factor is shortening the time consumed between the entry and exit of passengers with proper design of car door width.
 - The utilization of centre opening doors also favors the door opening and closing time periods. The centre opening door is much faster than the side opening type.

DESIGN OF LIFT LOBBY AND VERTICAL TRANSPORTATION CORE

LAYOUT OF BANKS OF ELEVATORS

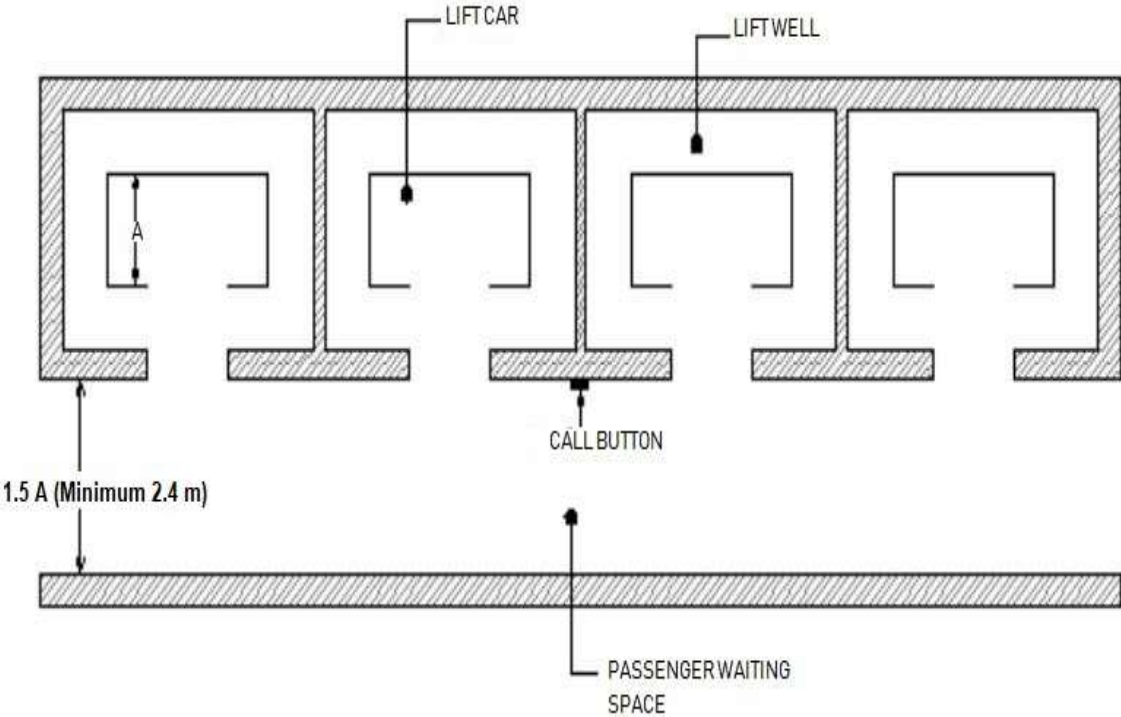

Figure: Four Car Arrangement

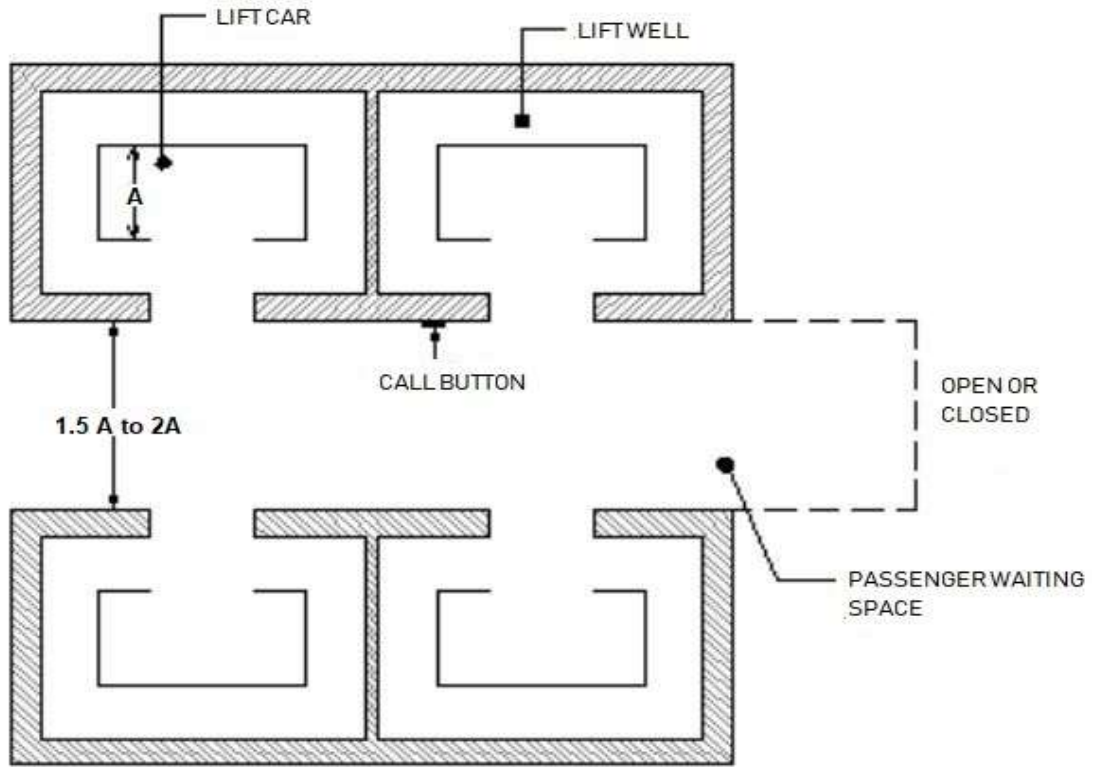

Figure: Four Car Arrangement

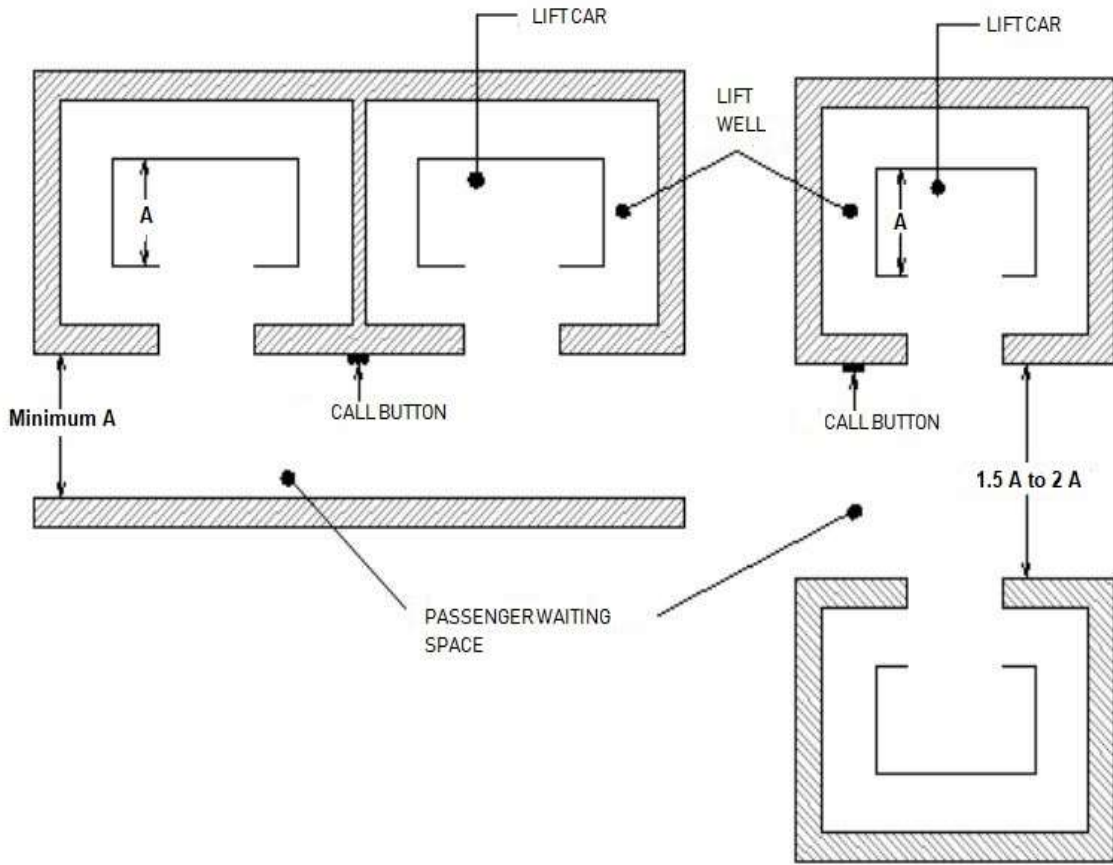

Figure: Four Car Arrangement

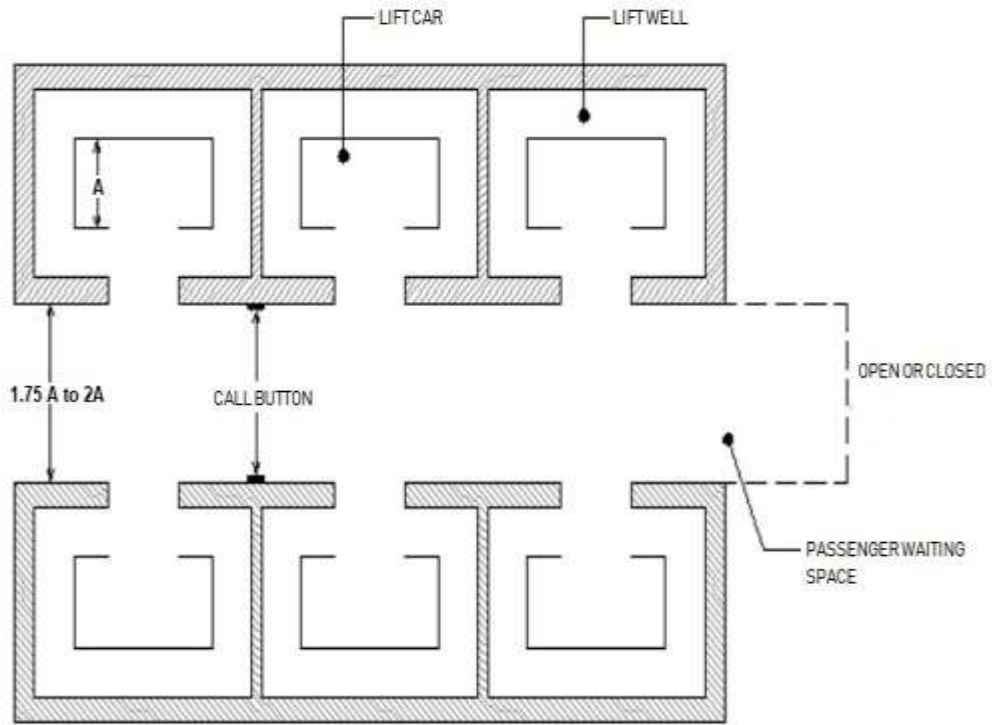

Figure: Six Car Arrangement

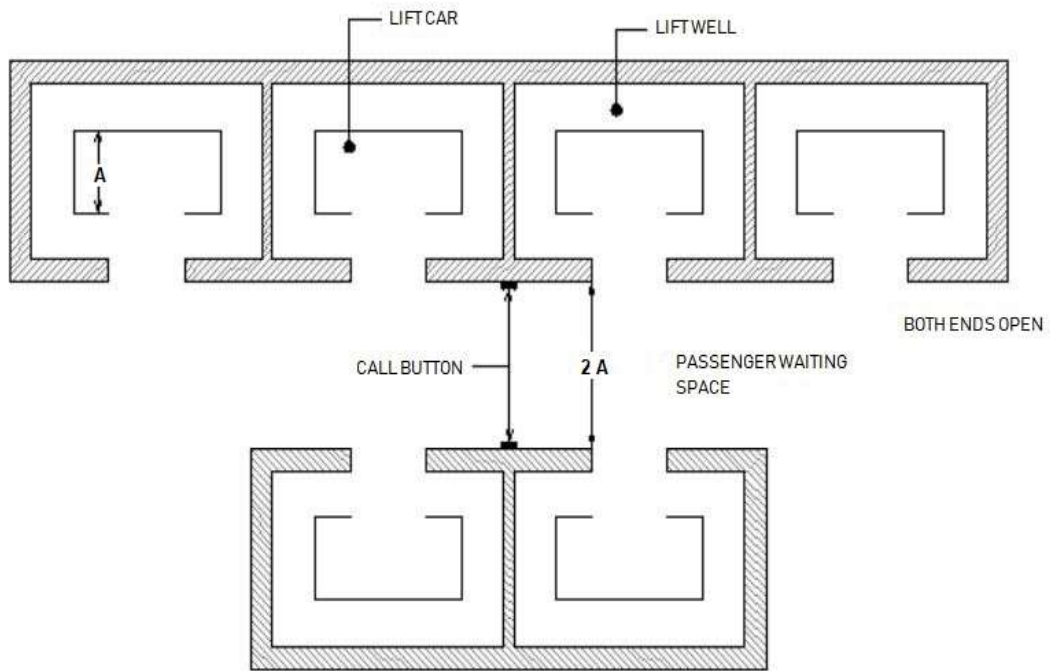

Figure: Six Car Arrangement

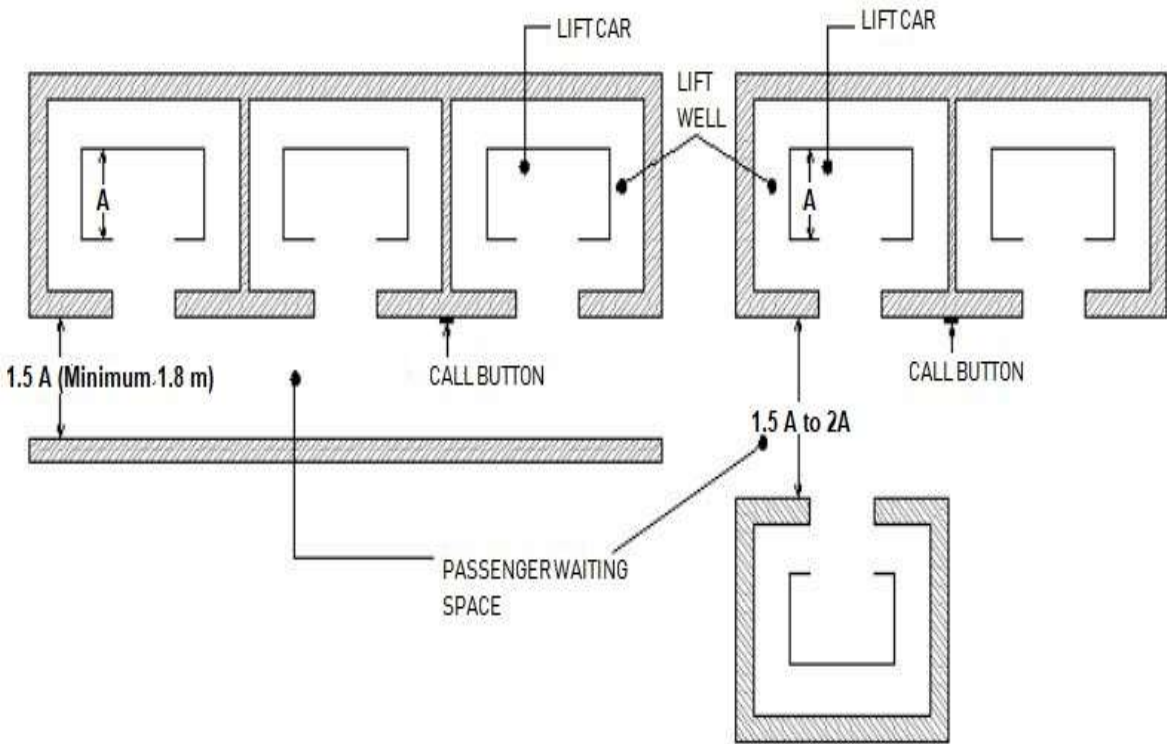

Figure: Six Car Arrangement

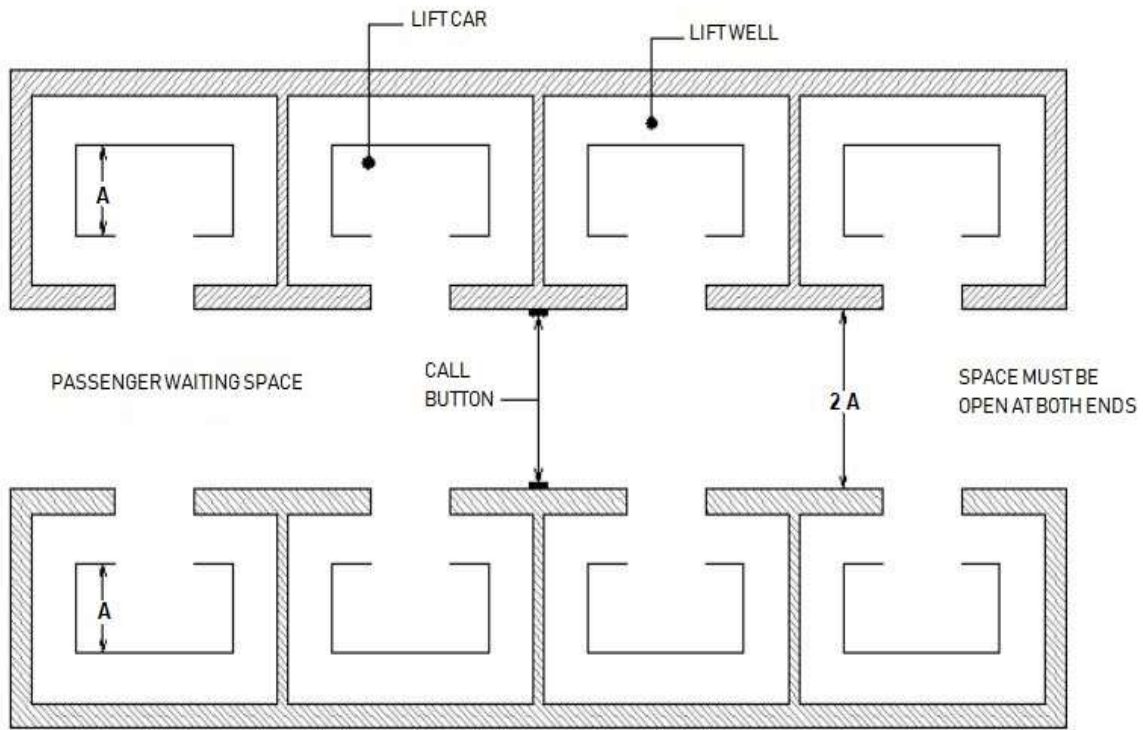

Figure: Eight Car Arrangement

A thorough investigation shall be carried out for assessing the most suitable location for lifts while planning the building. It shall take into account future expansions, if any.

The lifts shall be easily accessible from all entrances to the building. For maximum efficiency, they shall be grouped near the centre of the building. Walking distance from the lift to the farthest office or suite shall not exceed 60 m.

Arrangement of Lifts

(a) When more than one lifts are installed in a group, they shall be arranged side by side or in two rows facing each other. Separation of lifts in the group shall be avoided.

(b) The lift lobby in front of lifts shall be wide enough to allow sufficient space for waiting passengers and proper vision of hall button and hall lanterns. Above Figures give acceptable arrangements of lifts in a group with acceptable space for waiting passengers. More space shall be allowed in front of the lifts in the main floor than in the upper floors.

(c) It is preferable that the lift lobby is not used as a thoroughfare, but when absolutely needed the lift lobby shall be wider enough to take into account of the space for people who are moving.

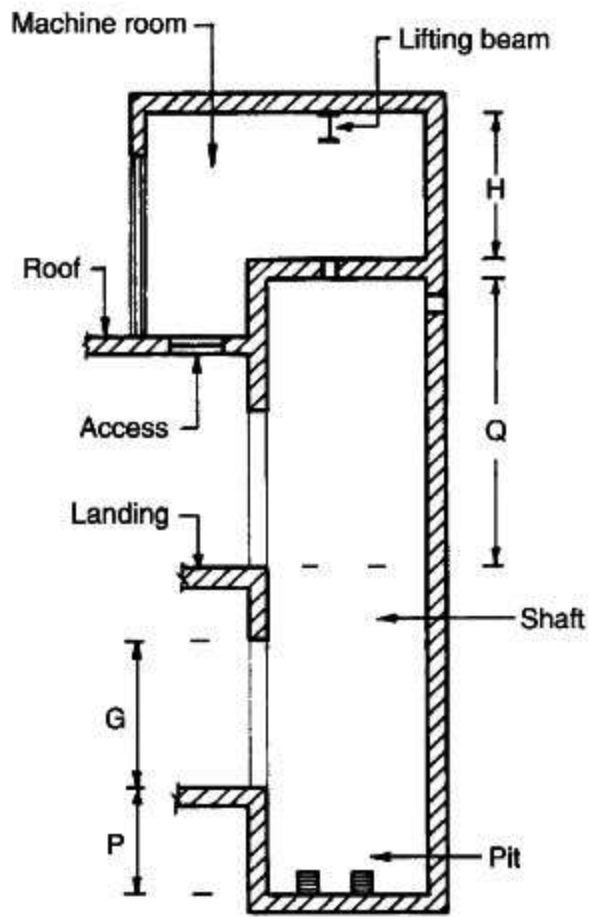

Vertical section

General-purpose electric traction lift

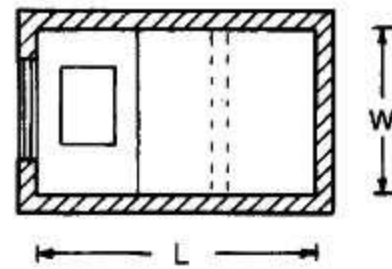

Plan section - machine room

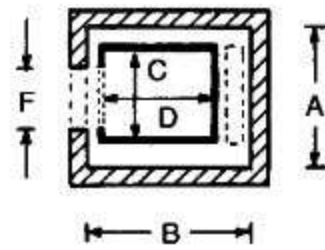

Plan section - shaft and car

All dimensions in metres:

Shaft size		Car size			Door size		Pit	Machine room			
A	B	C	D	E	F	G	P	Q	H	L	W
1.8	2.1	1.1	1.4	2.2	0.8	2.0	1.7	4/4.2	2.6	3.7	2.5
1.9	2.3	1.35	1.4	2.2	0.8	2.0	1.7	4/4.2	2.6	3.7	2.5
2.4	2.3	1.6	1.4	2.3	1.1	2.1	1.8	4.2	2.7	4.9	3.2
2.6	2.3	1.95	1.4	2.3	1.1	2.1	1.9	4.4	2.7	4.9	3.2
2.6	2.6	1.95	1.75	2.3	1.1	2.1	1.9	4.4	2.8	5.5	3.2

Note: Dimension E refers to the car door height.

PLANNING AND LOCATING SERVICE CORES IN BUILDINGS

To function efficiently and to provide access for the elderly and disabled, modern offices and public buildings are provided with suitably designed lift installations. Planning (as with all services) should commence early in the design programme. Priority must be given to locating lifts centrally within a building to minimise horizontal travel distance. Consideration must also be given to position, relative to entrances and stairs. Where the building size justifies several passenger lifts, they should be grouped together. In large buildings it is usual to provide a group of lifts near the main entrance and single lifts at the ends of the building. The lift lobby must be wide enough to allow pedestrian traffic to circulate and pass through the lift area without causing congestion. For tall buildings in excess of 15 storeys, high speed express lifts may be used which by-pass the lower floors.

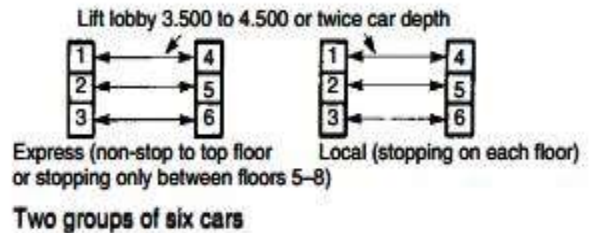
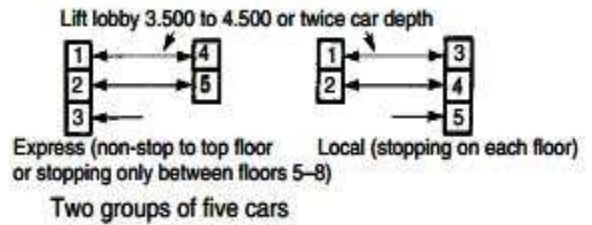
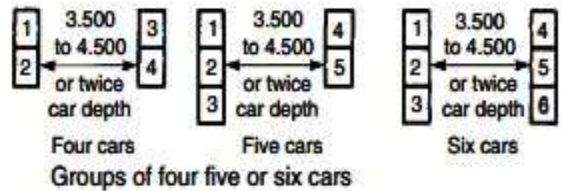
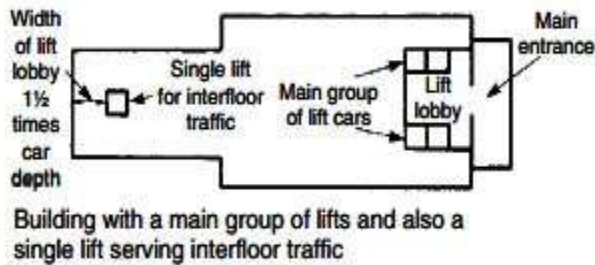
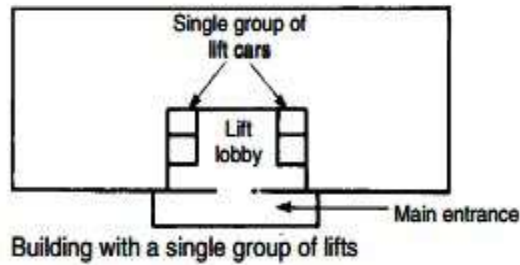

Core is one of the most important structural and functional elements of the high rise building. The core of a building is the area reserved for elevators, stairs, mechanical equipments and the vertical shafts that are necessary for ducts, pipes and wires. Its wall are also the most common location for the vertical wind bracing. The placement of the service core stems from four generic types which are : - Central core - Split core - End core - Atrium core

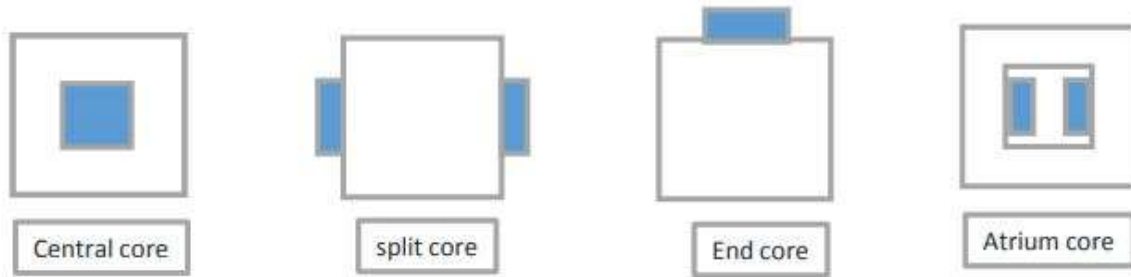

CONVEYORS

Conveyor Systems are mechanical devices or assemblies that transport material with minimal effort. While there are many different kinds of conveyor systems, they usually consist of a frame that supports either rollers, wheels, or a belt, upon which materials move from one place to another. They may be powered by a motor, by gravity, or manually. These material handling systems come in many different varieties to suit the different products or materials that need to be transported.

Important Conveyor Systems Specifications

Load Capacity per Unit Length

Manufacturers will offer this attribute in cases where the conveyor will be built to a custom length to permit users to determine loading margins.

Maximum Load Capacity

Associated with Load Capacity per Unit Length, this value can be stated for fixed length, purpose-built conveyors. This can also be known as flow rate.

Conveyor Belt System Speed/Rated Speed

Belt conveyors are typically rated in terms of belt speed in ft/min. while powered roller conveyors described the linear velocity in similar units to a package, carton, etc. moving over the powered rollers. Rated speed applies to apron/slat conveyors and drag/chain/tow conveyors as well.

Throughput

Throughput measures the capacity of conveyors that handle powdered materials and similar bulk products. It is often given as a volume per unit time, for instance, as cubic feet per minute. This attribute applies to bucket, pneumatic/vacuum, screw, vibrating, and walking beam conveyors.

Frame Configuration

Frame configuration refers to the shape of the conveyor frame. Frames can be straight, curved, z-frames, or other shapes.

Drive Location

Drives can be located in different places on conveyor systems. A head or end drive is found on the discharge side of the conveyor and is the most common type. Center drives are not always at the actual center of the conveyor, but somewhere along its length, and are mounted underneath the system. They're used for reversing the direction of a conveyor.

Types of Conveyors

Belt

Roller

Powered Roller

Slat/Apron

Ball Transfer

Magnetic

Bucket

Chute

Drag/Chain/Tow

Overhead

Pneumatic/Vacuum

Screw/Auger

Vertical

Vibrating

Walking Beam

Wheel

Belt

Belt Conveyors are material handling systems that use continuous belts to convey products or material. The belt is extended in an endless loop between two end-pulleys. Usually, one or both ends have a roll underneath. The conveyor belting is supported by either a metal slider pan for light loads where no friction would be applied to the belt to cause drag or on rollers. Power is provided by motors that use either variable or constant speed reduction gears.

The belts themselves can be made from numerous materials, which should correspond to the conditions under which the belt will be operating. Common conveyor belting materials include rubber, plastic, leather, fabric, and metal. Transporting a heavier load means a thicker and stronger construction of conveyor belting material is required. Belt conveyors are typically powered and can be operated at various speeds depending on the throughput required. The conveyors can be operated horizontally or can be inclined as well. Belt conveyors can be troughed for bulk or large materials.

Roller Conveyor Systems

Roller Conveyors use parallel rollers mounted in frames to convey product either by gravity or manually. Key specifications include the roller diameter and axle center dimensions. Roller conveyors are used primarily in material handling applications such as on loading docks, for baggage handling, or on assembly lines among many others. The rollers are not powered and use gravity, if inclined, to move the product, or manually if mounted horizontally. The conveyors can be straight or curved depending on the application and available floor space.

Powered Roller

Powered Roller Conveyors use powered rollers mounted in frames to convey products. Key specifications include the drive type, roller diameter and material, and the axle center dimension. Powered roller conveyors are used primarily in material handling applications that require the powered conveyance of the product. Various drive types include belts, chains/sprockets, and motorized rollers. Some of the uses of powered roller conveyors are food handling, steelmaking and, packaging.

Slat Belt Conveyor/Apron

Apron/Slat Conveyors use slats or plates made of steel, wood, or other materials typically mounted on roller chains to convey product. The slats are not interlocked or overlapping. Apron/slat conveyors are used primarily in material handling applications for moving large, heavy objects including crates, drums, or pallets in heavy-industry settings such as foundries and steel mills. The use of slats in heavy duty use cases prolongs the service life of the conveyor over other conveyor types that employ belts, which would wear out quicker under the exposure to heavy loads. These conveyor systems are usually powered and come in many sizes and load capacities.

Ball Transfer Conveyor

Ball Transfer tables or conveyors use a series of mounted ball casters to allow for unpowered, multi-directional conveyance of the product. Key specifications include the ball material and size. Ball transfer conveyors are used in material handling applications such as assembly lines and packaging lines, among others. When positioned where multiple conveyor lines meet, they are used to transfer products from one line to another and are often used in sorting systems. Many sizes and load carrying capacities are available. Ball transfer conveyors are not powered and rely on external forces to move the product along the conveyor.

Magnetic

Magnetic Conveyors use moving magnets mounted beneath stationary plates, tables, or other kinds of non-magnetic slider beds, to move magnetic (ferrous) materials, often in the form of machining scrap. Magnetic conveyors are commonly used as chip conveyors to remove ferrous chips from machining centers. Systems can be configured to use horizontal motion, vertical motion, or combinations. They can be beltless or may use a conveying belt instead of a slider bed. Underneath the conveying belt, a rail containing an electromagnet is

used to attract ferrous materials to the belt. Because of the magnetic attraction of the product to the conveyor, these systems can also be used upside down.

Bucket

Bucket Conveyors or bucket elevators use multi-sided containers attached to cables, belts, or chains to convey products or materials. The containers remain upright along the system and are tipped to release material. Bucket conveyors are used in applications such as parts, bulk material, or food processing and handling. The conveyed material can be in liquid form or dry such as sludge, sand, manure, sugar, and grain. The systems can be used horizontally or can be inclined or vertical to change levels of the delivered products. Many sizes and load carrying capacities are available depending on the application.

Chute

Chute or Trough Conveyors are material handling systems that use gravity to convey product along smooth surfaces from one level to another. Key specifications include the chute material and the physical dimensions such as length and chute width. Chute conveyors are used for scrap handling, packaging, postal service package or mail handling, etc. Chutes are designed to have a low coefficient of dynamic friction, allowing the product or material to slide easily, and can be straight or curved depending on the needs of the application.

Chain/Tow/Drag Line Conveyor

Drag/Chain/Tow Conveyors use mechanical devices attached to moving members, usually chains or cables, to drag or tow products. Drag conveyors are used for moving bulk materials in bins, flights, or other attachments and can have multiple discharge or loading points. Tubular drag conveyors use a fully enclosed system of chains to convey product in any direction. Chain conveyors use a chain, or multiple chains to move pallets or other hard-to-convey products. Tow conveyors use a towline such as cables or chains, usually in the floor or just above it, to tow product directly or to tow wheeled carts or dollies.

Overhead

Overhead Conveyors are mounted from ceilings that use trolleys or carriers moved by chains, cables, or similar connections. Overhead conveyors are primarily used in material handling applications where the product needs to be hung, such as dry-cleaning garment

lines, paint lines, or parts handling systems, or for cooling and curing. Various types of overhead conveyor systems configurations are available including electric track, monorail, trolley, as well as inclined or ramped. Depending on the application, the load-carrying capacity may be critical. Most overhead conveyors systems are powered and controlled, while others are hand-operated conveyor belts.

Pneumatic/Vacuum

Pneumatic/Vacuum Conveyors use air pressure or vacuum to transport materials or items in or through closed tubes or ducts or along surfaces. Pneumatic/vacuum conveyors are used primarily in materials handling applications such as dust collection, paper handling, ticket delivery, etc. and in processes such as chemical, mineral, scrap, and food. Materials for the conveyors can be metallic or non-metallic depending on the media being conveyed. Various sizes are available depending on the load and throughput requirements.

Horizontal Belt Conveyors

A conveyor system is a mechanical handling equipment that moves materials from one location to another. Conveyors are especially useful in applications involving the transportation of heavy or bulky materials. Conveyor systems allow quick and efficient transportation for a wide variety of materials, which make them very popular in the material handling and packaging industries.

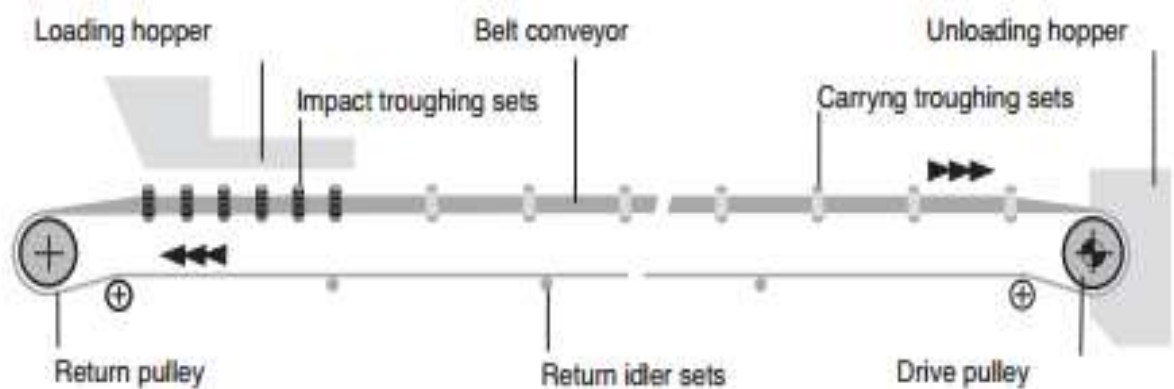

Short conveyors (maximum 2 m (6 ft))

In this case belt support on the return side can be omitted. Screw type take-up (TU) can be necessary for adjustment of catenary sag. Observe perfect parallel alignment of shafts.

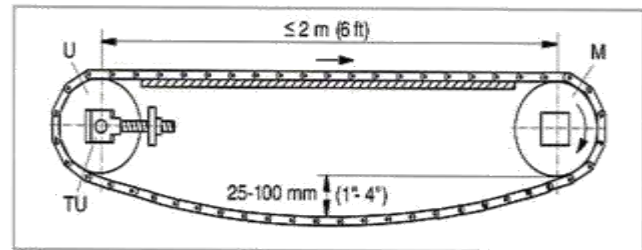

Medium length conveyors (2 to 4 m (6 to 12 ft))

Common design; belt on return way supported by slider frame (SR) or wear strips. Rollers (R1) can be used as well. A catenary sag near the driving sprockets is sufficient for moderate temperature changes.

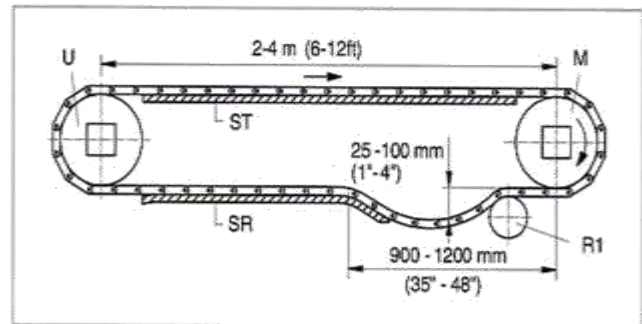

Long conveyors (over 4 m (12 ft))

Longer lengths and greater temperature changes require more than one section for catenary sag. Special concern to vary the roller spacings over long conveyors.

Admissible speeds of long conveyors:

Length	max. speed
up to 15 m (45 ft)	50 m/min (150 ft/min)
15 - 25 m (45 - 75 ft)	30 m/min (90 ft/min)
over 25 m (75 ft)	15 m/min (45 ft/min)

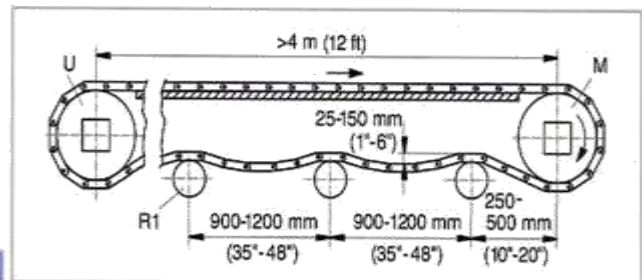

DUMB WAITER

A dumbwaiter elevator is a very small freight elevator that's intended to carry objects instead of people. Commercially, you'll often find them in hospitals, restaurants, hotels, and schools. They're now also a popular addition to the home, with dumbwaiter installation making it easier to move things upstairs and downstairs.

Window type

The window type dumbwaiter is installed at the height of a man's waist, so that customers can conveniently use the system. This type is most suited to carry books and documents at libraries, offices, banks etc.

This system can also be used to carry kitchen utensils, food and beverages in places such as hotels and restaurants.

Floor type

The floor type dumbwaiter is installed on the same horizontal level with the floor of the passage way to facilitate carriage of cargoes which are normally carried on handcarts.

This type is very convenient because it is easy to carry large cargoes like restaurant tables.

Standard Dimensions & Reactions

(단위: mm)

No.	Model	Loading Capacity (Kg.)	Speed (m/min)	Entrance		Car Interior		Hoistway & Machine Room Size		Hoistway		Motor Capacity (kw)
				Opening Type	Kind	A x B	Height (H)	Width (X)	Depth (Y)	Overhead	Pit	
1	TD50-25U	50	25	2 sheet up-down open & close type	one side	550 × 550	750	910	935	1375	750	1.5
2	TD50-25JD				transfix			1093	810			
3	TD75-25U	75			one side	600 × 600	800	960	985	1450		
5	TD75-25JD				transfix			1143	860			
6	TD100-25U	100			one side	700 × 700	900	1060	1085	1600		
6	TD100-25JD				transfix			1243	960			
7	TD150-25U	150			one side	800 × 800	1000	1160	1185	1750		
8	TD150-25JD				transfix			1370	1060			
1	FD200-25U	200	25	1 sheet up open & close type	one side	800 × 1000	1200	1160	1410	2650	400	2.2
2	FD200-25JD				transfix			1370	1310			
3	FD300-25U	300			one side	850 × 1150	1200	1210	1560			
4	FD300-25JD				transfix			1420	1460			

Note: The Car outside size can be variable with the type of the entrance

Table type

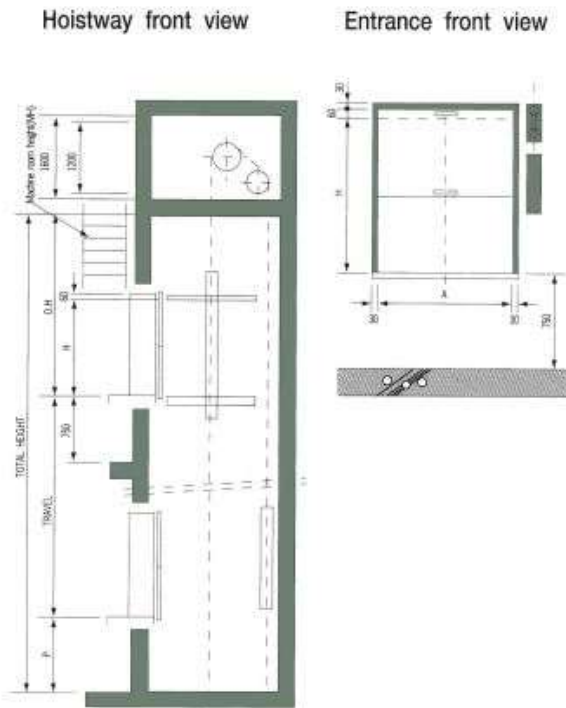

Floor type

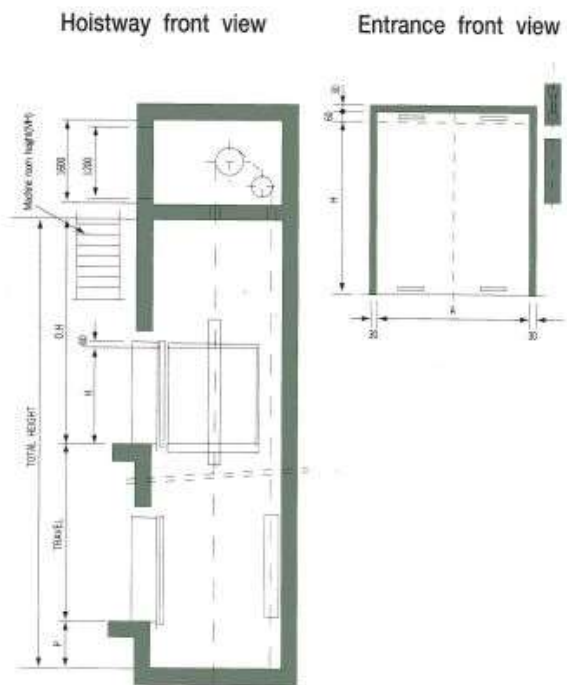

LATEST INNOVATIONS

The Compass system speed the passenger on his/her way with efficient, personalized service. It helps them avoid the crowds, skip stops, and get where they are going without the extra wait. The system ensures an easy trip for every passenger, such as featuring standard Braille keypads, voice instructions and floor announcements, interactive directories, and additional time to enter and exit the elevator for passengers with disabilities. It also has the ability to designate specific elevators for deliveries or other building needs. Otis Compass can be applied in multiple elevator banks and either single or double deck elevators.

In 2013, Otis launched a new generation of the Compass destination dispatch system called CompassPlus. It replaces the traditional up and down push-button elevator system with an array of customizable touch-capable fixtures in the elevator lobbies. A passenger enters his or her destination from the hallway, rather than from inside the elevator, using a keypad or

touchscreen device; receives an elevator assignment, which is shown on the touchscreen; follows directions to the assigned elevator; and proceeds to his or her destination

INTEGRATION OF LIFTS AND ESCALATORS WITH BUILDING AUTOMATION SYSTEMS.

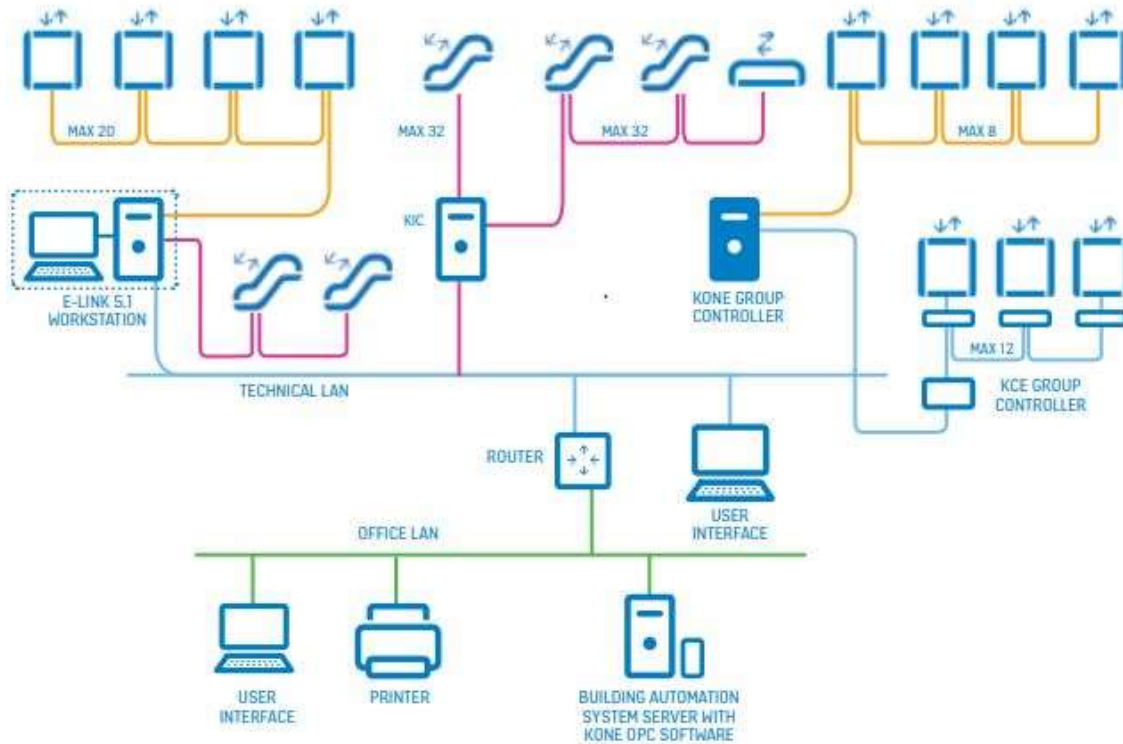

E-LINK FUNCTIONS AND FEATURES

- Traffic monitoring
- Deviation alarms
- Elevator and escalator operation reporting
- Operational event history
- Traffic history playback
- Elevator calls and commands
- Elevator locking
- Remote monitoring
- Scheduled calls and commands

INTERFACE TO BUILDING MANAGEMENT SYSTEM

- OPC Data Access 2.05A

MAXIMUM SYSTEM SIZE

- Total number of elevators:
 - unlimited
- Total number of escalators:
 - unlimited
- Total number of user interface computers: unlimited

MONITORING

- User configurable real time traffic displays
- Status displays
- Building layouts

REPORTS

- Calls per hour
- Calls per floor
- Waiting times per hour
- Waiting times per floor
- Elevator availability
- Elevator operation summary
- Escalator operation summary
- Number of alarms, alarm log

ELEVATOR STATISTICS

- Number of hall calls
- Hall call time
- Number of starts
- Start load
- Stop time
- Run time
- Cycle time
- Re-levelings
- Number of starts in bank
- Availability
- Operational Time

DOUBLE-DECKER ELEVATOR STATISTICS

- Lower deck load
- Upper deck load
- Both decks serving time

DESTINATION ELEVATOR STATISTICS

- Number of passenger calls
- Waiting time
- Time to destination
- Transit time

ESCALATOR STATISTICS

- Availability
- Run time
- Number of starts
- Number of emergency stops
- Number of disturbances

PLAYBACK

- Display of traffic history
- Linked with operational event history

ELEVATOR CALLS AND COMMANDS

- Car calls
- Priority calls
- Attendant service
- Independent service
- Simplex service
- Out of service
- Special parking
- Scheduling possibility
- Escalator remote control

ELEVATOR LOCKING COMMANDS

- Scheduled locking
- Manual locking

OPERATIONAL EVENT HISTORY

- Alarms
- Deviations
- Status changes

SYSTEM CONFIGURATION

- Languages: call for availability

UNIT 5

INTEGRATION OF SERVICES INTO ARCHITECTURAL DESIGN

Principles of grouping and integrating of horizontal and vertical distribution of all services in a multi- storeyed building/ large building. (ELECTRICAL)

- ★ In large buildings the type of distribution depends on the building type, dimension, the length of supply cables, and the loads.
- ★ The distribution system can be divided in to:
 - The vertical supply system (rising mains).
 - The horizontal supply (distribution at each floor level).
- ★ In most cases a high voltage supply and transformer substation is required. Normally HV switchgear and substation transformers are installed at ground floor (or basement).
- ★ However, often there are appliances with large power demand installed on the top floors (converters and motors for lifts, air conditioning equipment and electric kitchens).
- ★ As it is desirable to bring the high voltage supply as close as possible to the load centers, transformers are installed at the top floor, or if required, additional ones are installed on one of the intermediate floors.
- ★ In such cases transformers with non-inflammable insulation and cooling are used. The arrangement of the rising mains depends on the size and shape of the building and suitable size of shafts for installing cables and bus ducts must be provided in coordination with the building architect.
- ★ The vertical supply system are implemented in several ways, some of which are :

Single Rising main:

Applications :-

- ★ Where high supply security is not important.

Advantages :-

- ★ a) The different loads of individual floors are balanced out.
- ★ b) Only a small main L.V board is required.
- ★ c) Simple in construction and operation.

Disadvantages :-

- ★ Low supply security (a fault in the rising mains effect all floors).

Single Rising Main

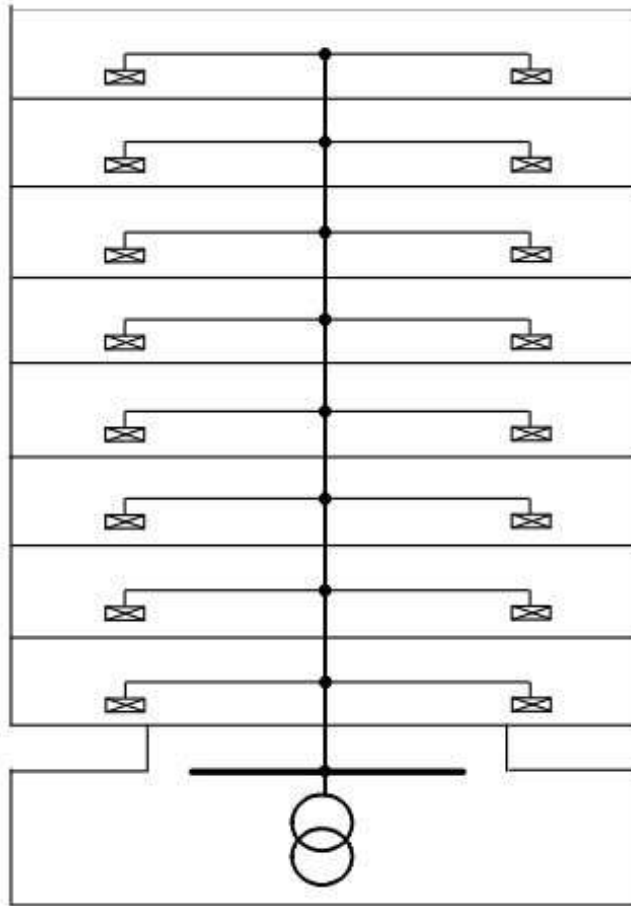

Grouped supply

Applications :-

High rise building with high load concentration.

Advantages :-

- Easier mounting.
- Smaller size for rising mains.

Disadvantages :-

- A fault in any rising mains effect several floors (relatively low security).
- Loads are balanced only within each group.
- Larger power distribution board.

Grouped Supply

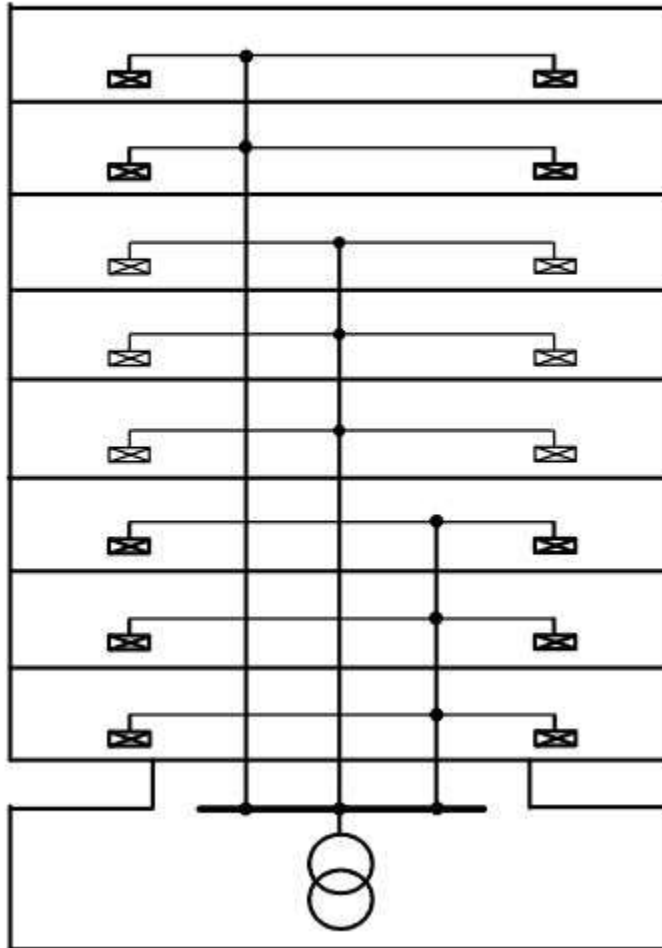

Individual Floor Supply

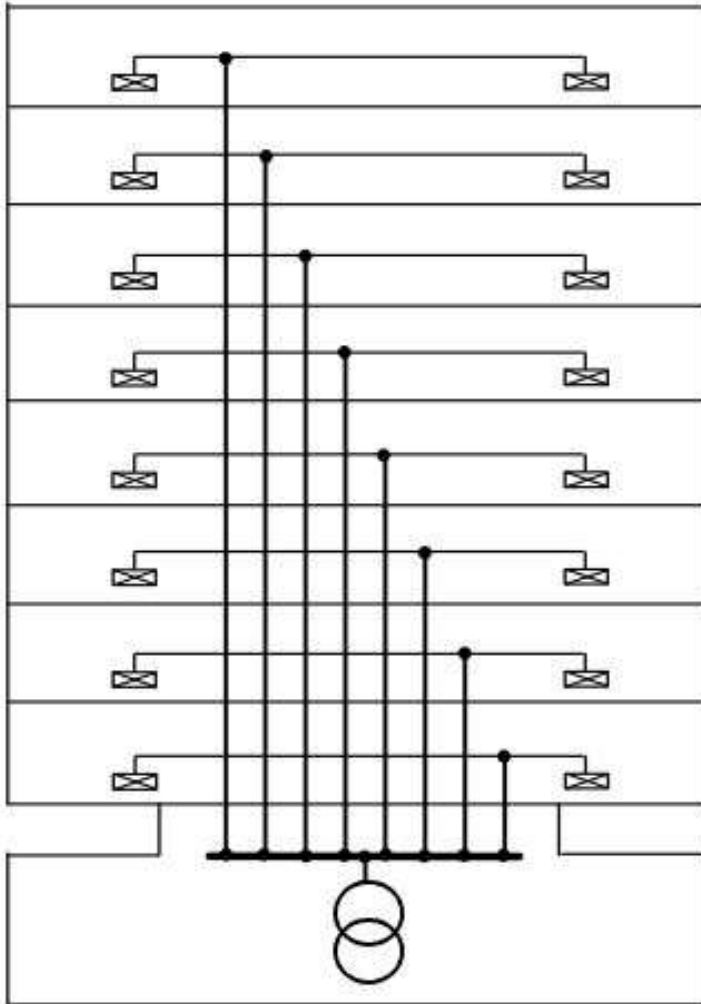

Applications :-

- In high rise buildings where stories are let separately (metering is at central point at ground floor).

Advantages :-

- Smaller size of cables can be used (easy installation).
- In the case of a fault in arising main, only one story is effected.

Disadvantages:-

- a) Different loading of the individual floors can not be balanced out.
- b) The rising main must be rated for the peak load of each floor.
- c) Uneconomical – large number of cables and the size of the rising main shaft is quite large.
- d) Large low voltage distribution board with numerous circuits.

Principles of grouping and integrating of horizontal and vertical distribution of all services in a multi- storeyed building/ large building(VERTICAL TRANSPORTATION)

- Several numbers of passenger elevators are usually required in most buildings in order to cope with the traffic density and choosing the right elevator configuration can be a critical decision.
- In the interest of economy as well as even utilization, every effort should be made to achieve a layout where elevators can be combined into a group with an appropriate group control system.
- For Office buildings, one elevator group can generally serve all floors in buildings up to 15 to 20 floors depending on the building population. When there are more than 20 floors, single grouping is not efficient and would normally result in long travel times and congestion in the elevator lobbies during peak periods.
- The passenger elevators for buildings with more than 20 floors (up to about 35 floors), should be separated into low rise service and high rise service. Elevators in the low rise group should serve the lower half of the building while elevators in the high rise group travel directly from the main stop to the upper half of the building.
- Such a zoning arrangement would cut down on the number of stops per elevator, thus reducing round trip times and increasing the handling capacity of each group. Furthermore, the low rise group would then not require high speed elevators, thus providing an economical solution as well as more efficient distribution of the building population during peak periods.
- The same zoning principle is also applied in buildings with even greater number of floors where 3 or more elevator zones can and should be deployed. Efficiency of the passenger elevator service in a building is usually measured by the "5-minute handling capacity" and the "average destination time" which can be defined as the waiting time in the elevator lobby plus the travelling time inside the elevator. As a guide, the following are the guidelines for 5-minute handling capacity for different types of buildings:

Residential Apartments / buildings: 7 to 9%.

Premises without specific distribution traffic, such as mixed-tenancy Office buildings with different working hours: 12 to 16%.

Premises with excessive distribution traffic, such as single tenancy Office buildings with the same working hours: 16 to 25%.

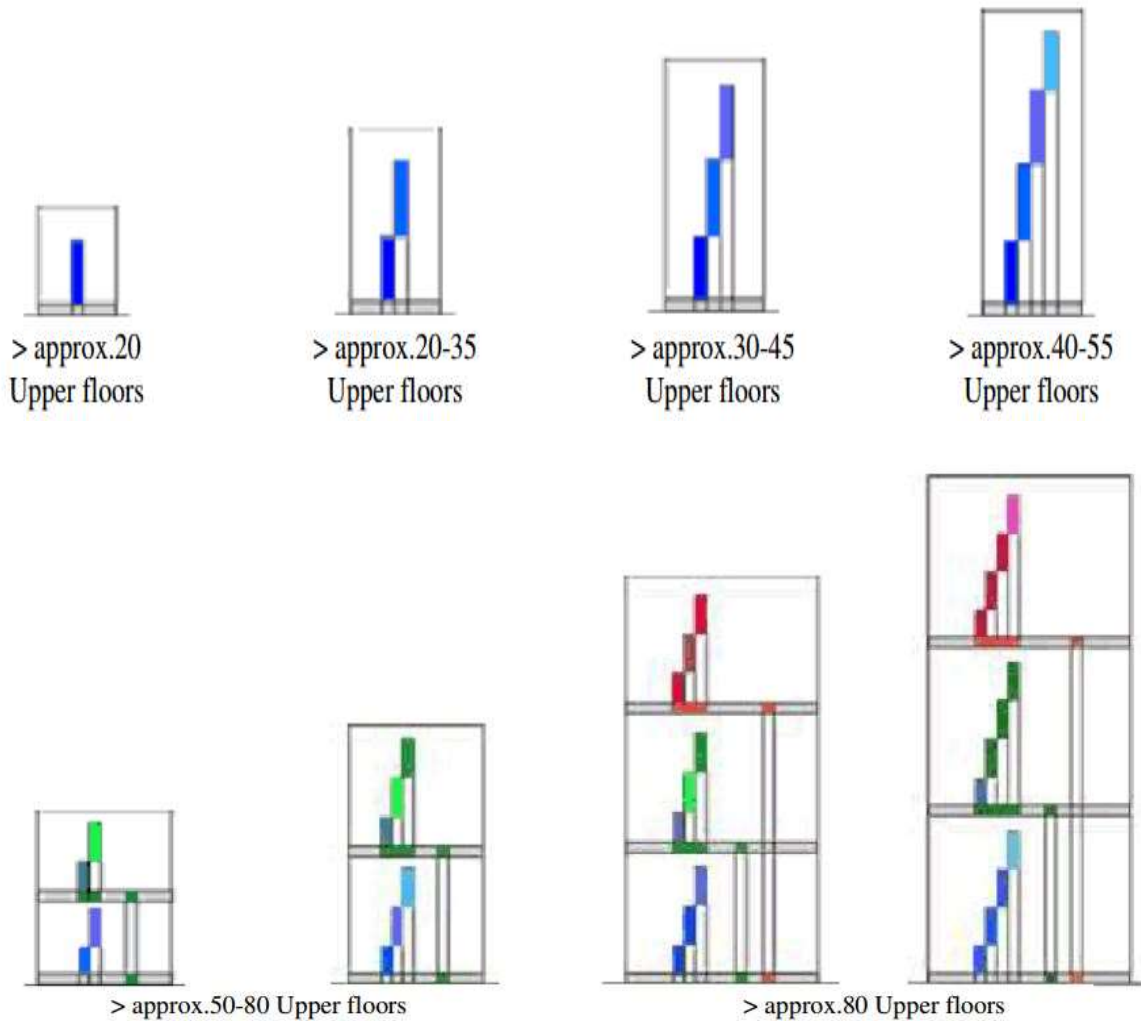

Planning Requirements

General Considerations

The design team will need to consider a whole spectrum of diverse factors, for example:

- The arrival rate of passengers into the building
- How close are rail and bus stations?

- Are the parking facilities self-contained or adjacent?
- How many building entrances are there?
- What is the mail distribution system in the building?
- The investment interests of the developer
- Is the building speculative?
- Is the owner a landlord or an occupant?
- The quality of the adjacent buildings
- Will new or existing tenants be attracted?
- Are there high-quality tenants looking to trade up or down in the neighboring area?
- Are the elevators in the adjacent buildings doing their job efficiently?

There could be over a hundred different possible configurations for your building's elevators, and each will have its advantages and disadvantages compared with the others. The professional team working to find that optimum solution will need expert advice, both in conceptualizing alternative schemes and in providing the multiple traffic calculations and simulations that will form the basis for the final design.

Individual Needs

The elevator requirements of both Commercial and Residential building can rarely be planned on the basis of brochures alone. Each building is unique, and the optimum solution will usually require individual variations from routine standards. For example:

- Very high buildings require extra hoist way clearance to allow for additional construction tolerances.
- Individual national regulations will need to be accommodated.
- Innovations in architectural styling or structure may necessitate a radical approach to the layout.
- Escalators may be more appropriate than elevators between adjacent floors. Frequently, interchange floors or main lobbies with public spaces above them (such as retail) will be better served by escalators, freeing the elevators for longer-distance travelers.
- High rise buildings need fireman's lift which serves every floor according to national code requirements.

GENERAL PLANNING FOR ESCALATORS AND PASSENGER CONVEYORS

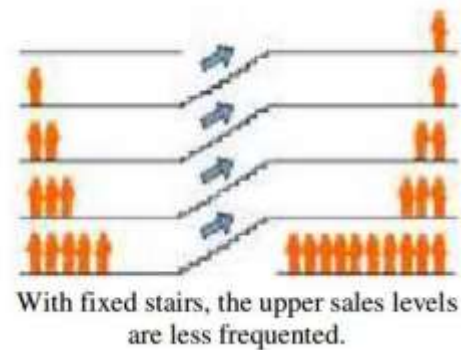
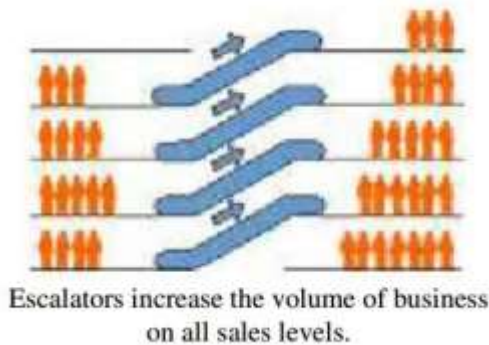

Applications for escalators and passenger conveyors

Escalators and passenger conveyors enable a constant stream of passengers, even at a high transport volume. In the commercial sector, consumers get to become familiar with all sales levels. This gives escalators the potential to boost sales. In public transport, escalators can transport passengers quickly at high traffic volumes.

Speeds and transport capacities

Speeds of between 0.45 and 0.5 m/s are the common international standard. Speeds of 0.65 and 0.75 m/s are only recommended for higher rises or in public transport. Increasing the speed does not lead to a proportional rise in transport capacity, since users hesitate longer before stepping on the unit. Depending on the given situation (location, application), the effective transport capacity may measure up to 80% of the theoretical values. The transport of baggage carts reduces transport capacity significantly. In addition to a group of two or more escalators, a passenger elevator should be provided for the transport of strollers and wheelchairs.

HORIZONTAL & VERTICAL DISTRIBUTION OF SERVICES FOR LARGE BUILDINGS (HVAC)

- Under-floor distribution Air-conditioning system distribution and terminal equipment is generally located overhead in the ceiling void with the cool supply air entering the room from ceiling diffusers.
- However, the supply of conditioned air from under the floor is a design option. In this case, the air or water distribution and terminal devices are located in the floor void, and hence the overhead services are reduced to only lighting and sprinklers.
- By making the floor void deep enough, the power, telecommunications and computer wire ways may be incorporated into the one plenum, all being easily accessible by merely opening up the raised floor.

- Under-floor cooling is particularly beneficial for spaces such as computer rooms, as air velocities from floor grilles and resultant noise levels are both much higher for cooling of equipment than those which would be acceptable for people.

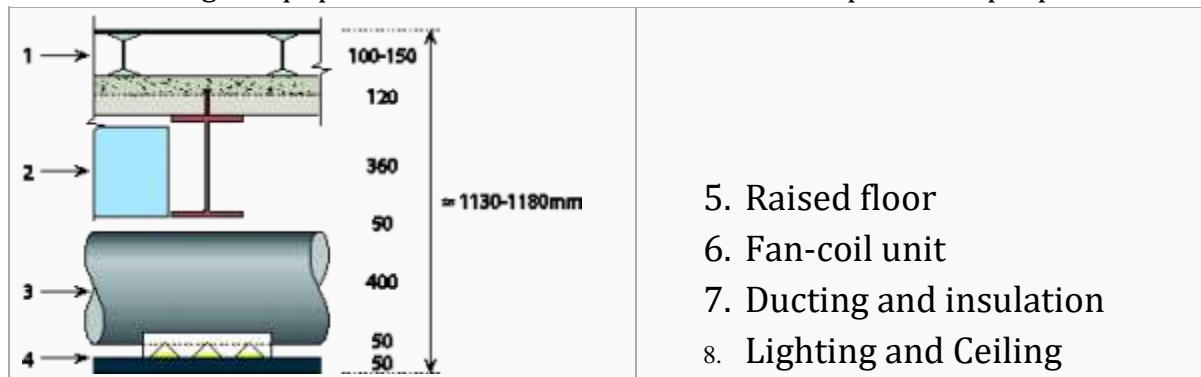

Services located below composite beams

- Internal distribution of services For many reasons, there is pressure to minimise the space allocated to the building services. Therefore, it is necessary to ensure an efficient use of space for the service distribution system in the vertical and horizontal directions and in the plant rooms.
- The following sections review the spatial aspects of the vertical and horizontal service distribution.
- Conventionally, the horizontal distribution of services is arranged within a horizontal layer which is generally located below the structure and above the suspended ceiling.
- This layer accommodates the distribution system (ducts, pipes, etc), the terminal units and lighting units. The raised floor is placed on the floor slab and accommodates the electrical and communication cabling. The lighting units are often located within the ceiling depth. To determine the spatial allowance for these elements, three design cases may be envisaged corresponding to different structural configurations:
 1. A flat slab with flexibility of service routing.
 2. A slab and down stand beam arrangement.
 3. A long span beam system with facility for service integration in the structural depth.

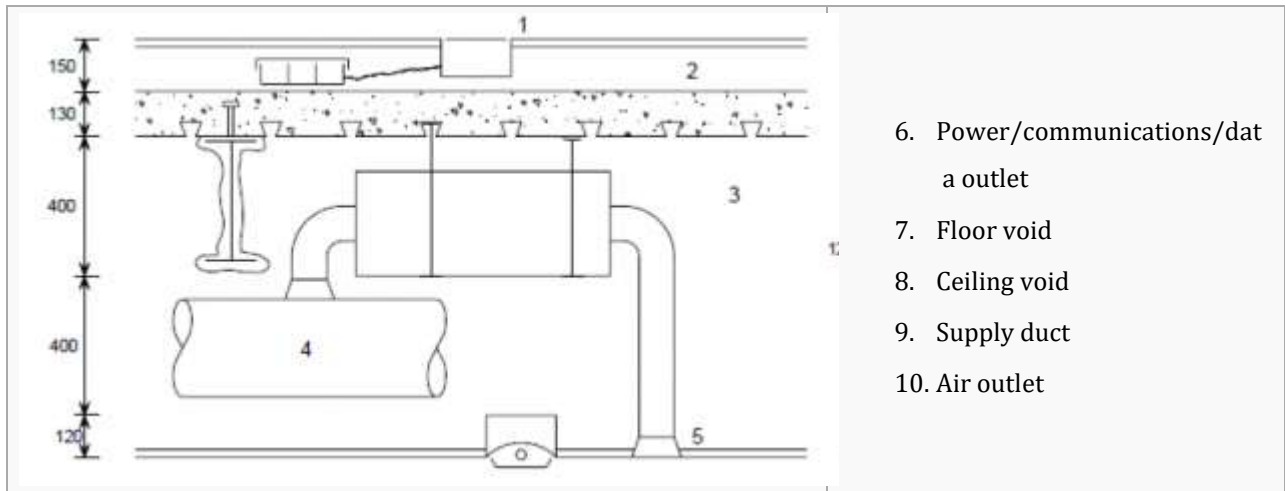

Example of integrated services Case 2 – Slab and downstand beam arrangement

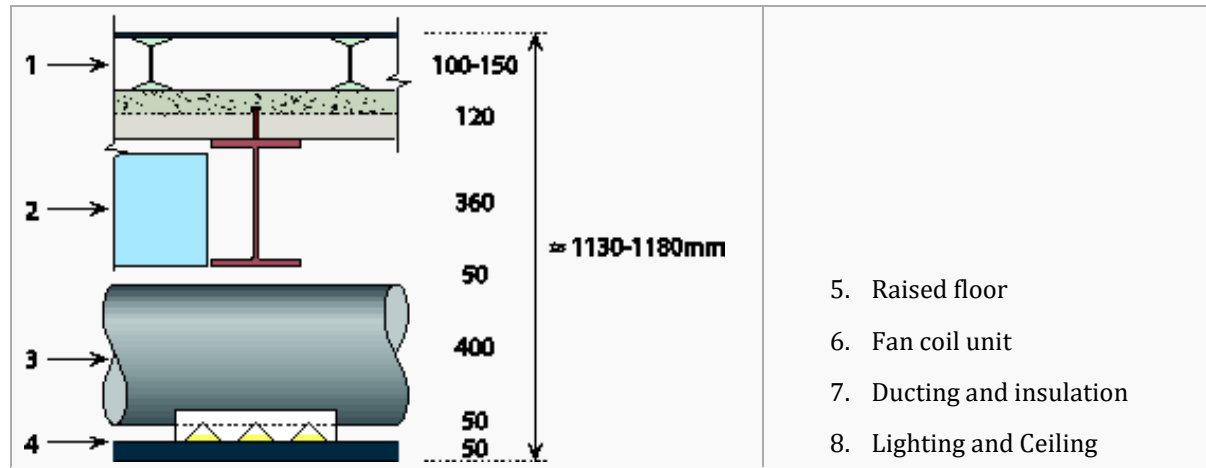

Services located below composite beams



Example of integrated services Case 3 – Long span beam with web openings

In case 1, the ducts pass below the floor within the depth allowed for the terminal units. However, cross-overs of ducts must be avoided in order to minimize this depth. In cases 2 and 3, the terminal units may be located between the beams, which means that additional space below the beams is required only for the major ducts, ceiling and lighting units. In case 3, the ducts are located entirely within the structural zone as they pass through large openings in the deep beams. Typically, the diameter of these openings is 400mm, and the duct size is 300 or 350mm allowing for insulation etc. Vertical distribution of services

Vertical dimensions for the following components	Case 1 Flat soffit (mm)	Case 2 Downstand beams (mm)	Case 3 Long span beams (mm)
Allowance - deflection & fire protection	30	50	50 to 75
Lighting units and ceiling	100 to 150	100	100
VAV box and attachments	400	Nil	Nil
		(boxes between beams)	
Ducts and insulation	<400 , but no cross-overs	400 (inc. insulation)	Nil- 400mm dia. openings
Total (below structure)	550	500	150 to 175
Raised floor	150	150	150
Structural depth (typical)	300 to 400	550	800 to 900
Total (ceiling-floor)	1,000 to 1,100	1,200	1,100 to 1,200
Typical vertical dimensions between ceiling and floor			

The following recommendations apply to the vertical distribution of services:

- ✓ Provide continuous and uninterrupted vertical service routes
- ✓ Maintain a constant cross-section of the service route
- ✓ Position the plant room so that it is as close as possible to the centre of the plan area it serves
- ✓ Consider the connection between horizontal services and vertical services routes
- ✓ Provide separate routes for different services. The minimum is two; one for electrics and one for water pipes, etc., although most buildings require more service routes

- ✓ Horizontal distribution should ideally not extend more than 25 m from a vertical service route. Longer distances will impose penalties on the system design and increase the depth of horizontal service ducts
- ✓ Position plant rooms at no more than 10 storeys apart vertically.

The figure shows typical arrangements of vertical service routes. Vertical ducts which transfer air from the roof-top plant to each floor can often be concentrated in a relatively small riser, as shown below

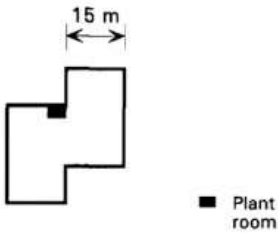
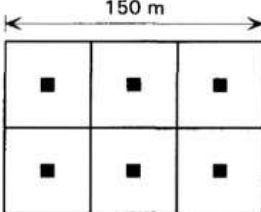
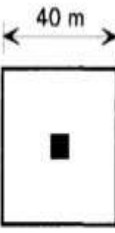
Type	Plant	Notes
Small building (up to four storeys and up to 2500 m ² total floor area)		One plant room, one riser. Location of riser not important, due to small size of building (central location preferred). Plant room must be adjacent to the riser
Large plan building (4000 m ² total floor area)		Several plant rooms adjacent to areas served. Some central plant, for example for gas intake and boilers, may be required
Large, tall building (over 15 storeys)		Plant room floors at basement and roof level. Intermediate plant rooms may be required. Vertical distribution within central core

L-shaped building (1000 m² to 3000 m² per floor), (3 -10 storeys)

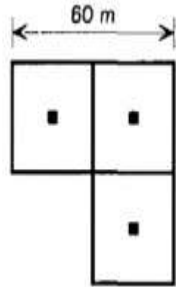

Several plant rooms, several risers. Risers and air plant rooms adjacent to cores. Separate room located at ground/basement level for new electric supply

Building with atrium (typically 2000 m² per floor), (5 - 10 storeys)

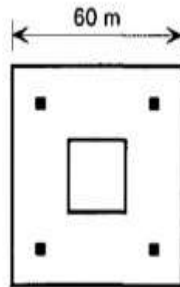

Four roof air plant rooms, one basement plant room. Four risers related to cores. Basement plant below atrium gives best connection to risers

Typical arrangements of plant rooms and vertical service routes

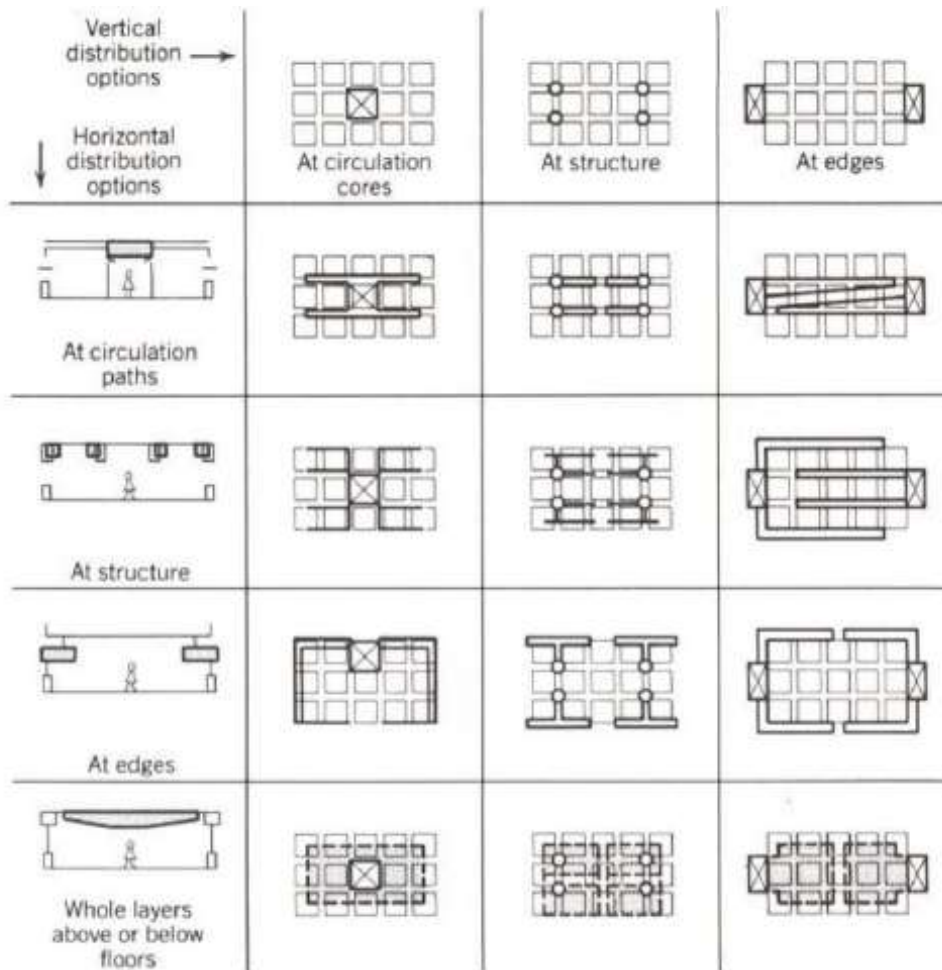

HORIZONTAL DISTRIBUTION OF SERVICES THROUGH CENTRAL CORRIDOR

- ★ The horizontal distribution system for mechanical and electrical services should be planned simultaneously with the structural frame and the interior finish systems, because the three are strongly interrelated.
- ★ The floor to floor height of a building is determined in part by the vertical dimension needed at every story for horizontal runs of duct work and piping.
- ★ The selection of finish ceiling, partition and floor systems is often based on their ability to contain the necessary electrical and mechanical services and to adjust to future changes in these services. All these strategies involve close cooperation among the architect and the structural and mechanical engineers.
- ★ Plumbing walls, they will not interfere with other services. Sprinkler heads which have the next highest priority in the layout of horizontal services are served from the fire stand pipe by horizontal piping that seldom exceeds 4 in. (100mm) in outside diameter.
- ★ The spacing of the heads is coordinated with the placement of walls and partitions the maximum coverage per head is about 200 sq. ft. (18.6 m²) in light hazard buildings such as churches, schools, hospitals, office buildings, museums and

auditoriums. Coverage in industrial and storage buildings ranges from 130 to 90 sq. ft. (12.1 to 8.4 m²) per head, depending on the substances handled in the building.

- ★ Air conditioning ducts, the next priority branch out from a local fan room or from a vertical ducts in supply and return ducts. Return ducts are often very short and confined to the interior areas of the building.
- ★ Supply ducts extend through low velocity secondary ducts to air diffusers throughout the occupied area of the floor. Diffusers are generally required at the rate of four to seven diffusers per 1000 sq. ft. (100m²).

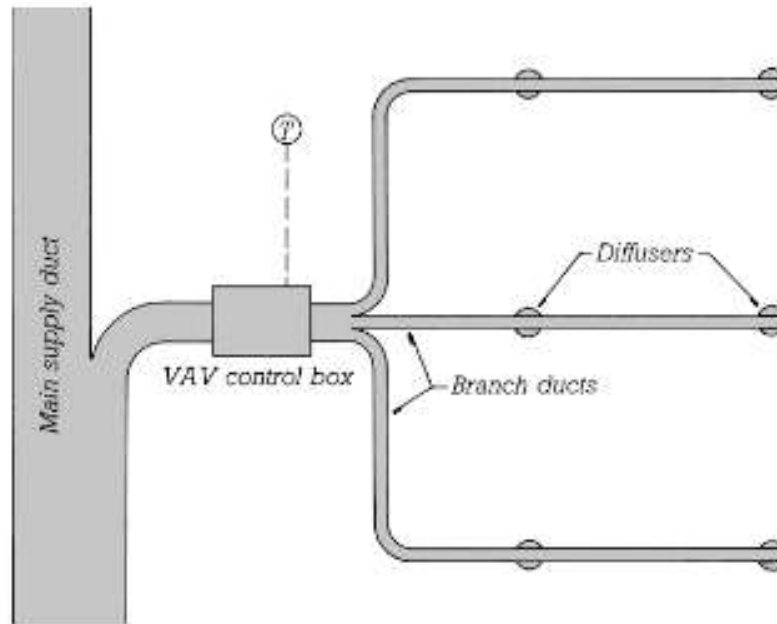

Figure: Plan of VAV Duct

GROUPED HORIZONTAL DISTRIBUTION OVER CENTRAL CORRIDORS:

- ★ Sometimes the major runs of duct work, piping and wiring can be grouped in the ceiling area above the central corridor of each floor of a building, leaving the ceilings of the surrounding rooms essentially clean.
- ★ This works especially well in hotels and apartment buildings that rely on above ceiling all water or electric equipment adjacent to corridor for heating, cooling and ventilating.
- ★ A low corridor ceiling is readily accepted in exchange for high, unobstructed space in the occupied rooms, where the structure may be left exposed as the finish ceiling, saving cost and floor to floor height.
- ★ If the building has a two way flat plate or hollow core precast slab floor structure, the overall thickness of the ceiling floor structure can be reduced to as little as 8 in. (200 mm) Conduits containing wiring for the lighting fixtures may be cast into the floor slabs or exposed on the surface of the ceilings.

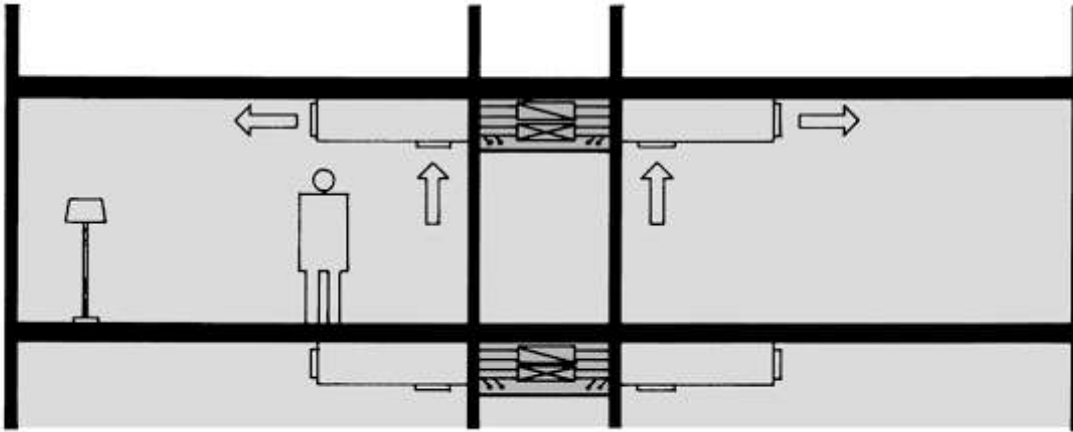

Figure: Grouped Horizontal Distribution over a Central Corridor

IN FLOOR AND RAISED ACCESS FLOOR DISTRIBUTION OF MECHANICAL SERVICES:

- ★ **Underfloor air distribution (UFAD)** is an air distribution strategy for providing ventilation and space conditioning in buildings as part of the design of an HVAC system.
- ★ UFAD systems use an underfloor supply plenum located between the structural concrete slab and a raised floor system to supply conditioned air through floor diffusers directly into the occupied zone of the building.
- ★ Thermal stratification is one of the featured characteristic of UFAD system, which allows higher thermostat setpoints compared to the traditional overhead systems (OH).
- ★ UFAD cooling load profile is different from a traditional OH system due to the impact of raised floor, particularly UFAD may have higher peak cooling load than OH systems.
- ★ UFAD has several potential advantages over traditional overhead systems, including layout flexibility, improved thermal comfort, improved ventilation efficiency, improved energy efficiency in suitable climates and reduced life cycle costs.
- ★ UFAD is often used in office buildings, particularly highly-reconfigurable and open plan offices where raised floors are desirable for cable management.
- ★ UFAD is appropriate for a number of different building types including commercials, schools, churches, airports, museums, libraries etc.
- ★ Careful considerations need to be paid in the construction phase of UFAD systems to ensure a well-sealed plenum to avoid air leakage in UFAD supply plenum.

DISTRIBUTION ABOVE STRUCTURAL FLOOR:

- A raised access floor system allows maximum flexibility in running services because it can accommodate piping, ductwork, and wiring with equal ease.
- It is especially useful in industrial or office areas where large number of computers or computer terminals are used and where frequent wiring changes are likely.

- Through floors can be raised to any desired height above the structural deck, heights of 4 to 8 in. (100 to 200 mm) are most common. Less costly lower profile systems ranging from 2 1/2 to 3 in. (65 to 75 mm) in height are also available

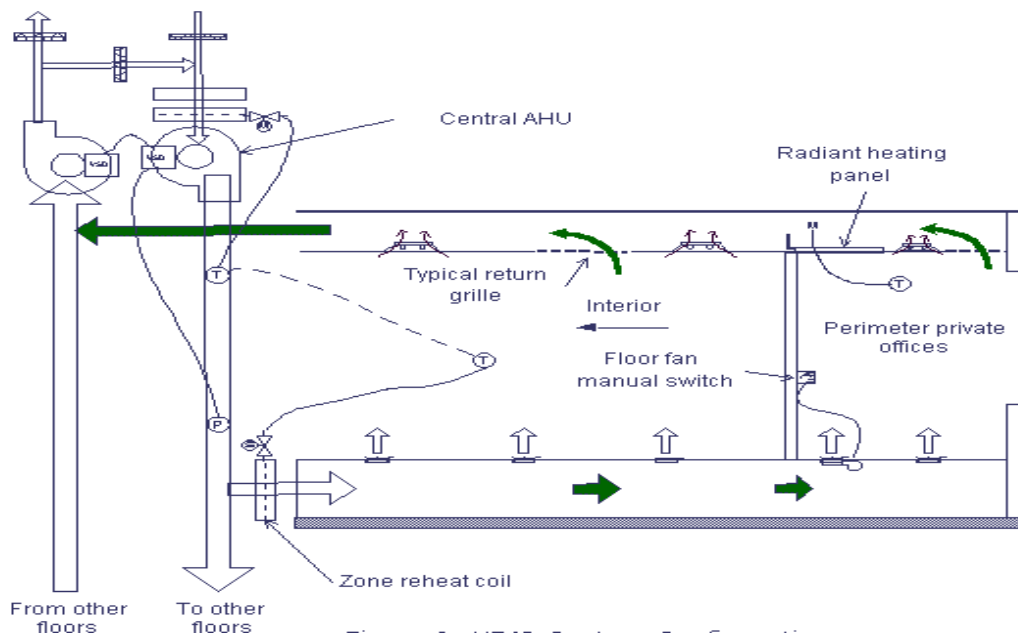
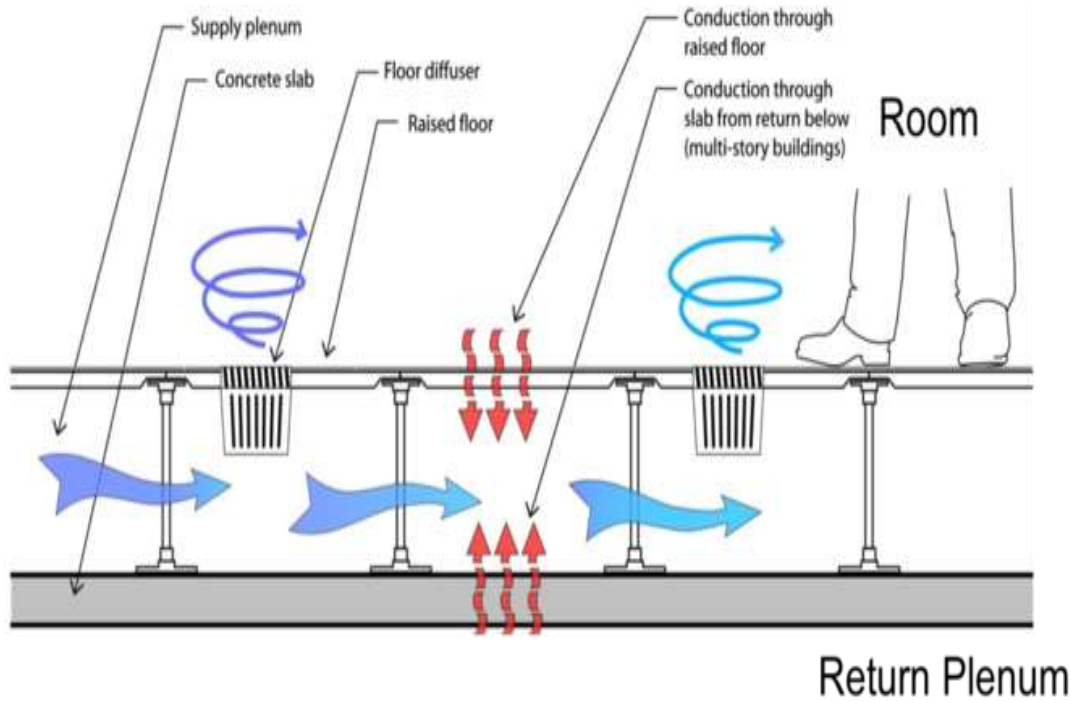

Principles of grouping and integrating of horizontal and vertical distribution of all services in a multi- storeyed building/ large building. (FIRE SAFETY)

FIRE FIGHTING SYSTEMS

A fire fighting system is probably the most important of the building services, as its aim is to protect human life and property.

It consists of three basic parts:

- a large store of water in tanks, either underground or on top of the building, called fire storage tanks
- a specialised pumping system,
- a large network of pipes ending in either hydrants or sprinklers (nearly all buildings require both of these systems)

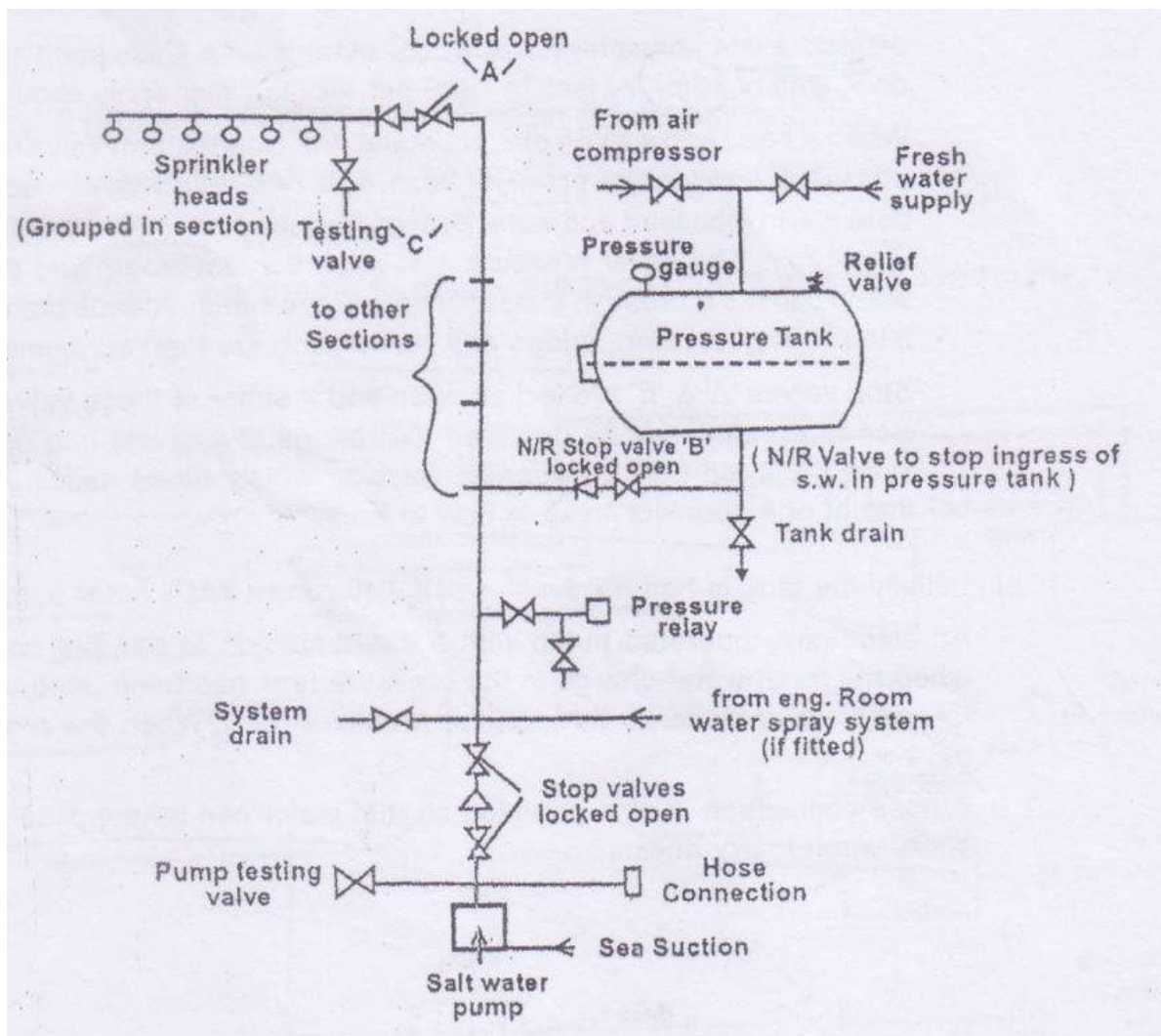

- ★ A fire hydrant is a vertical steel pipe with an outlet, close to which two fire hoses are stored (A fire hydrant is called a standpipe in America). During a fire, firefighters will go to the outlet, break open the hoses, attach one to the outlet, and manually open it so that water rushes out of the nozzle of the hose.
- ★ The quantity and speed of the water is so great that it can knock over the firefighter holding the hose if he is not standing in the correct way.
- ★ As soon as the fire fighter opens the hydrant, water will gush out, and sensors will detect a drop in pressure in the system. This drop in pressure will trigger the fire pumps to turn on and start pumping water at a tremendous flowrate.
- ★ A sprinkler is a nozzle attached to a network of pipes, and installed just below the ceiling of a room. Every sprinkler has a small glass bulb with a liquid in it. This bulb normally blocks the flow of water.
- ★ In a fire, the liquid in the bulb will become hot. It will then expand, and shatter the glass bulb, removing the obstacle and causing water to spray from the sprinkler. The main difference between a hydrant and a sprinkler is that a sprinkler will come on automatically in a fire.
- ★ A fire hydrant has to be operated manually by trained firefighters - it cannot be operated by laymen.
- ★ A sprinkler will usually be activated very quickly in a fire - possibly before the fire station has been informed of the fire - and therefore is very effective at putting out a fire in the early stages, before it grows into a large fire. For this reason, a sprinkler system is considered very good at putting out fires before they spread and become unmanageable.
- ★ General sprinklers are devices for a distributing water upon a fire in sufficient quantity to extinguish it completely or to prevent its spread, by keeping the fire under control, by the water discharged from the sprinklers.
- ★ The water for firefighting is fed to the sprinklers through a system piping, normally suspended from the ceiling, with the sprinklers installed at intervals along the pipes.
- ★ The orifice of the sprinkler head, incorporating the fusible link or fusible bulb of the automatic sprinkler, is normally kept closed, which is thrown open on the actuation of the temperature sensitive fusible link or fusible bulb.

FIRE STORAGE TANKS

- The amount of water in the fire storage tanks is determined by the hazard level of the project under consideration.
- Most building codes have at least three levels, namely, Light Hazard (such as schools, residential buildings and offices), Ordinary Hazard (such as most factories and warehouses), and High Hazard (places which store or use flammable materials like foam factories, aircraft hangars, paint factories, fireworks factories).
- The relevant building code lists which type of structure falls in each category. The quantity of water to be stored is usually given in hours of pumping capacity.

- In system with a capacity of one hour, the tanks are made large enough to supply the fire with water for a period of one hour when the fire pumps are switched on. For example, building codes may require light hazard systems to have one hour's capacity and high hazard 3 or 4 hours capacity.
- The water is usually stored in concrete underground tanks. It is essential to ensure that this store of water always remains full, so it must have no outlets apart from the ones that lead to the fire pumps.
- These tanks are separate from the tanks used to supply water to occupants, which are usually called domestic water tanks. Designers will also try and ensure that the water in the fire tanks does not get stagnant and develop algae, which could clog the pipes and pumps, rendering the system useless in a fire.

FIRE PUMPING SYSTEM

- ★ Fire pumps are usually housed in a pump room very close to the fire tanks. The key thing is that the pumps should be located at a level just below the bottom of the fire tank, so that all the water in the tanks can flow into the pumps by gravity.
- ★ Like all important systems, there must be backup pumps in case the main pump fails. There is a main pump that is electric, a backup pump that is electric, and a second backup pump that is diesel-powered, in case the electricity fails, which is common. Each of these pumps is capable of pumping the required amount of water individually - they are identical in capacity.
- ★ There is also a fourth type of pump called a jockey pump. This is a small pump attached to the system that continually switches on to maintain the correct pressure in the distribution systems, which is normally 7 Kg/cm² or 100 psi. If there is a small leakage somewhere in the system, the jockey pump will switch on to compensate for it. Each jockey pump will also have a backup.
- ★ The pumps are controlled by pressure sensors. When a fire fighter opens a hydrant, or when a sprinkler comes on, water gushes out of the system and the pressure drops.
- ★ The pressure sensors will detect this drop and switch the fire pumps on. But the only way to switch off a fire pump is for a fire fighter to do this manually in the pump room. This is an international code of practice that is designed to avoid the pumps switching off due to any malfunction in the control system.

The capacity of the pumps is decided by considering a number of factors, some of which are:

- The area covered by hydrants / standpipes and sprinklers
- The number of hydrants and sprinklers
- The assumed area of operation of the sprinklers
- The type and layout of the building

THE DISTRIBUTION SYSTEM

- The distribution system consists of steel or galvanised steel pipes that are painted red. These can be welded together to make secure joints, or attached with special clamps.
- When running underground, they are wrapped with a special coating that prevents corrosion and protects the pipe.

There are basically two types of distribution systems

Automatic Wet systems are networks of pipes filled with water connected to the pumps and storage tanks, as described so far.

- ★ Automatic Dry systems are networks of pipes filled with pressurized air instead of water. When a fire fighter opens a hydrant, the pressurized air will first rush out.
- ★ The pressure sensors in the pump room will detect a drop in pressure, and start the water pumps, which will pump water to the system, reaching the hydrant that the fire fighter is holding after a gap of some seconds.
- ★ This is done wherever there is a risk of the fire pipes freezing if filled with water, which would make them useless in a fire.
- ★ Some building codes also allow manual distribution systems that are not connected to fire pumps and fire tanks. These systems have an inlet for fire engines to pump water into the system.
- ★ Once the fire engines are pumping water into the distribution system, fire fighters can then open hydrants at the right locations and start to direct water to the fire. In high-rise buildings it is mandatory that each staircase have a wet riser, a vertical fire fighting pipe with a hydrant at every floor.
- ★ It is important that the distribution system be designed with a ring main, a primary loop that is connected to the pumps so that there are two routes for water to flow in case one side gets blocked.
- ★ In more complex and dangerous installations, high and medium velocity water-spray systems and foam systems (for hazardous chemicals) are used. The foam acts like an insulating blanket over the top of a burning liquid, cutting off its oxygen.
- ★ Special areas such as server rooms, the contents of which would be damaged by water, use gas suppression systems. In these an inert gas is pumped into the room to cut off the oxygen supply of the fire.

When you design a firefighting system, remember the following:

Underground tanks:

- water must flow from the municipal supply first to the firefighting tanks and then to the domestic water tanks. This is to prevent stagnation in the water.

- The overflow from the firefighting to the domestic tanks must be at the top, so that the firefighting tanks remain full at all times.
- Normally, the firefighting water should be segregated into two tanks, so that if one is cleaned there is some water in the other tank should a fire occur.
- It is also possible to have a system in which the firefighting and the domestic water are in a common tank. In this case, the outlets to the fire pumps are located at the bottom of the tank and the outlets to the domestic pumps must be located at a sufficient height from the tank floor to ensure that the full quantity of water required for firefighting purposes is never drained away by the domestic pumps.
- The connection between the two tanks is through the suction header, a large diameter pipe that connects the all the fire pumps in the pump room. Therefore there is no need to provide any sleeve in the common wall between the two firefighting tanks.
- The connection from each tank to the suction header should be placed in a sump; if the connection is placed say 300mm above the tank bottom without a sump, then a 300mm high pool of water will remain in the tank, meaning that the entire volume of the tank water will not be useable, to which the Fire Officer will object.
- Ideally the bottom of the firefighting pump room should be about 1m below the bottom of the tank. This arrangement ensures positive suction for the pumps, meaning that they will always have some water in them.
- All pump rooms should without fail have an arrangement for floor drainage; pumps always leak. The best way to do this is to slope the floor towards a sump, and install a de-watering pump if the water cannot flow out by gravity.
- In cases where there is an extreme shortage of space, one may use submersible pumps for firefighting. This will eliminate the need for a firefighting pump room.
- Create a special shaft for wet risers next to each staircase. About 800 x 1500 mm should suffice. It is better to provide this on the main landing rather than the mid landing, as the hoses will reach further onto the floor.
- Automatic sprinkler systems are quite effective for ensuring life safety, since they give early warning of the existence of fire and simultaneously start application of water on to the fire which will help control and extinguishment of the fire.

DRY RISERS

- Dry Riser Systems are installed in buildings for firefighting purposes by trained personnel and which are normally dry and are capable of being charged with water by pumping from Fire Service Appliances
- Dry Riser Systems are installed complete with an inlet breeching connector at Ground Floor or at Fire Service Access Level and with Landing Valves at specified points on each floor
- Dry Riser Systems are installed up to 50m above the Fire Service Access Level

- Wet Riser Systems are installed in a buildings for firefighting purposes by trained personnel and which are permanently charged with water from a pumped source
- Wet Riser Systems are installed complete with Landing Valves at specified points on each floor
- Wet Riser Systems are installed up to and above 50m subject to the system being designed to provide adequate flow and pressure at the upper floors

Dry Riser System

Dry fire main water supply pipe installed in a building for fire-fighting purposes, fitted with inlet connections at fire service access level and landing valves at specified points, which is normally dry but is capable of being charged with water usually by pumping from fire and rescue service appliances.

WET RISERS

Wet fire main water supply pipe installed in a building for fire-fighting purposes and permanently charged with water from a pressurized supply, and fitted with landing valves at specified points.

Where fire mains are installed and there are no floors higher than 50 m above fire service access level, wet or dry fire mains may be installed.

Where there are floors higher than 50 m above fire service access level, wet fire mains should be installed owing to the pressures required to provide adequate fire-fighting water supplies at the landing valves at upper floors and also to ensure that water is immediately available at all floor levels.

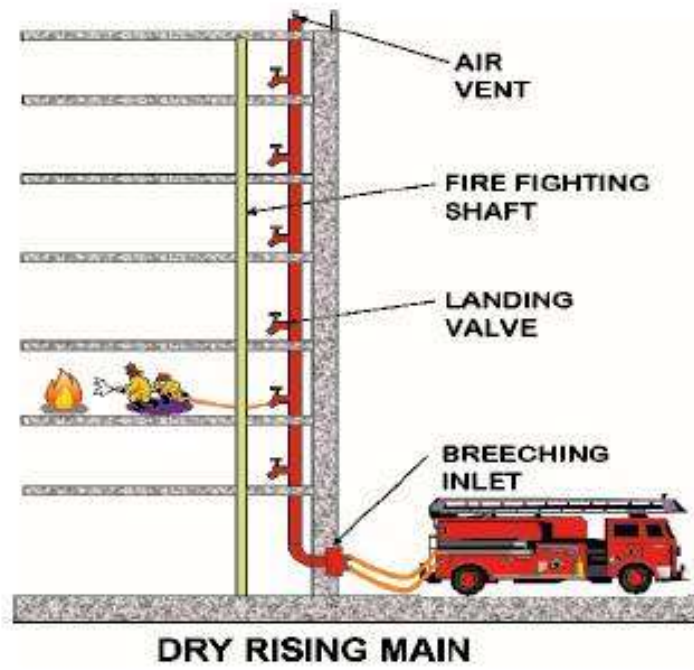

Figure: Dry Riser

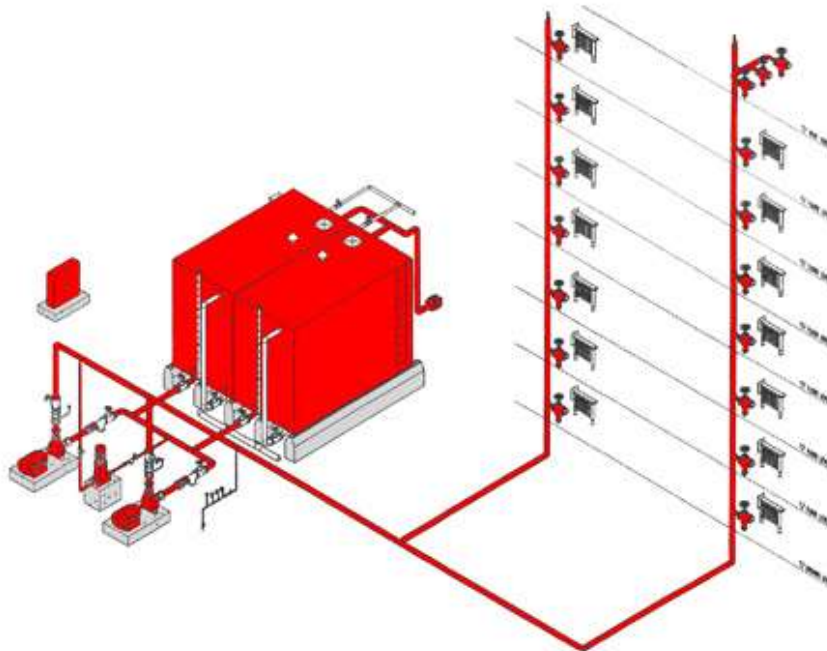

Figure: Wet Riser

SPRINKLER SYSTEM:

- ★ Each sprinkler head is made up of steel cage fitted with a water deflector. A quartzoid bulb, which contains a highly expansible liquid, is retained by the cage.
- ★ The upper end of the bulb presses against a valve assembly which incorporates a soft metal seal. Refer to the diagram below.

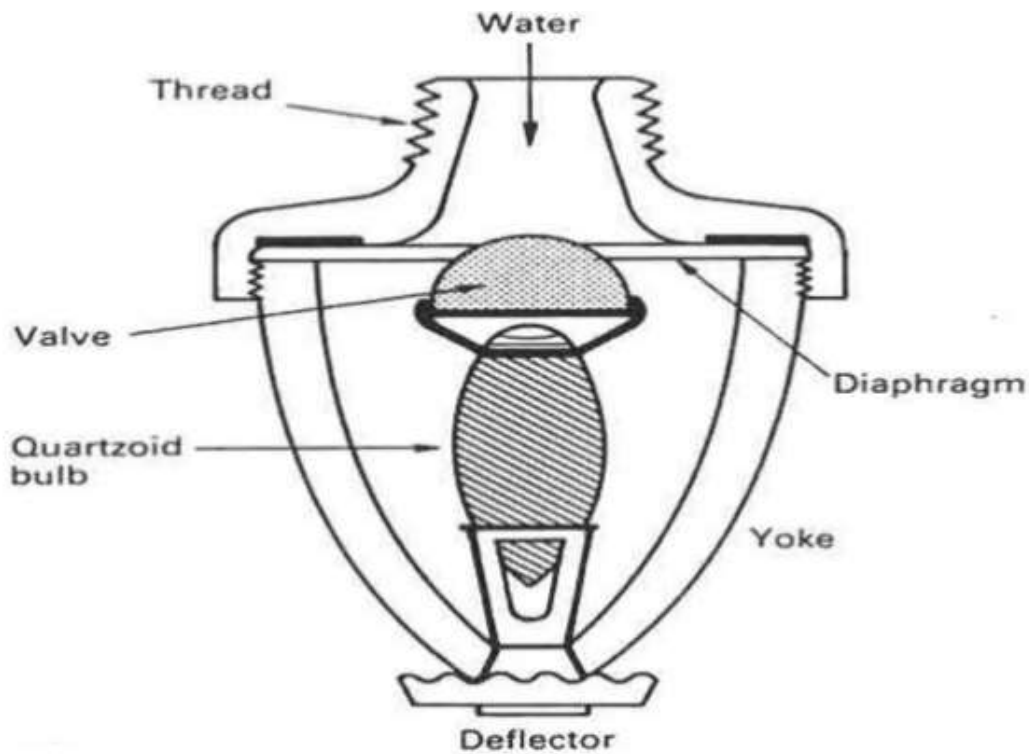

Figure: sprinkler head for sprinkler system

- ★ When quartzoid bulbs are manufactured, a small gas space is left inside the bulb so that, if the bulb is subjected to heat, the liquid expands and the gas space diminishes.
- ★ This will generate pressure inside the bulb and the bulb will shatter once a predetermined temperature is reached.
- ★ Once the bulb shatters the valve assembly falls permitting water to be discharged from the head which strikes the deflector plate and sprays over a considerable area.
- ★ Generally the operating temperature range of quartzoid bulbs is 68 °C to 93 °C but the upper limit of temperature can be increased. Quartzoid bulbs are manufactured in different colours which indicate the temperature rating of the bulb.

SPRINKLER COLOURCODES		
Glass Bulb	Opening temperature in °C	Temperature rating °C
Orange	57	57 - 77
Red	68	80 - 107
Yellow	79	121 - 149
Green	93 - 100	163 - 191
Blue	121 - 141	204 - 246
Mauve/ Purple	163 - 182	260 - 302
Black	204 - 260	320 - 343

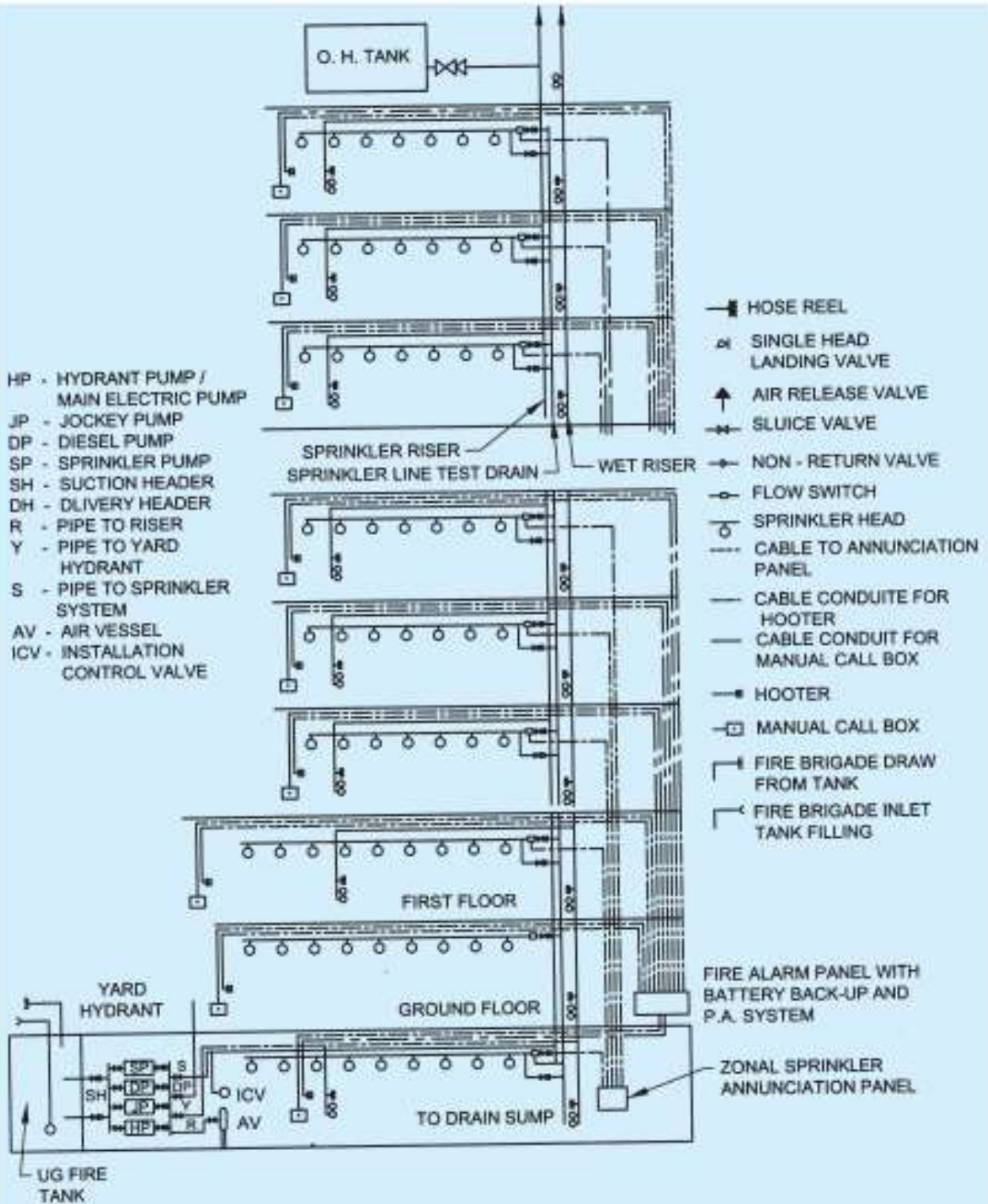
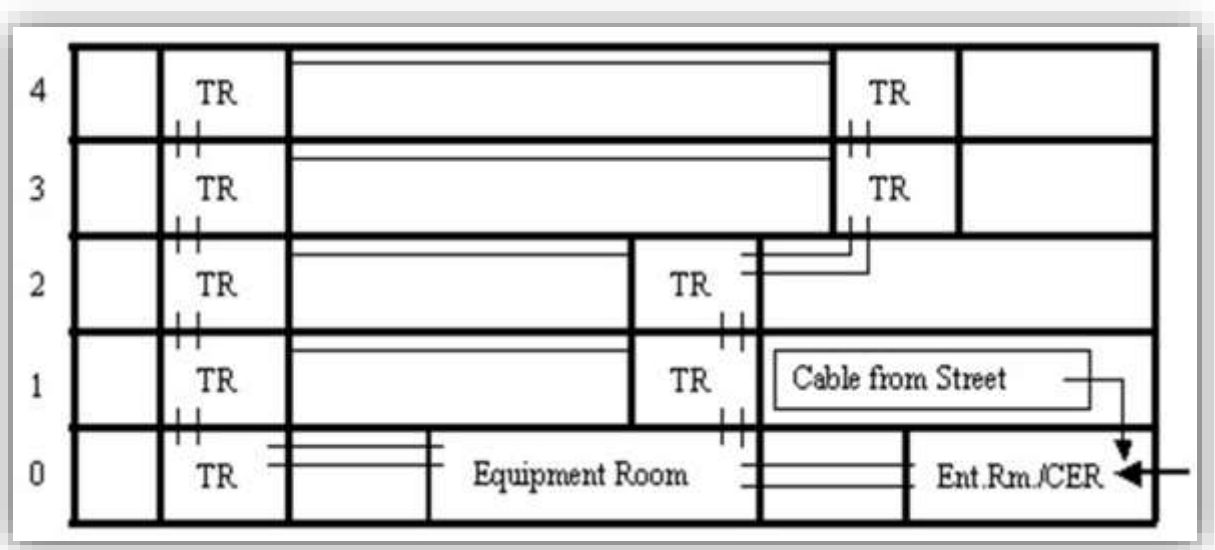

FIG. 3 TYPICAL ARRANGEMENT OF WET RISER AND TOTAL SPRINKLER SYSTEM OF BUILDING OTHER THAN APPARTMENT EXCEEDING 30 m IN HEIGHT

Communication

- * Telecommunications Spaces keep telecommunications equipment and terminations of telecommunications cables.
- * Telecommunications pathways transport the cables.
- * There is at least a telecommunications room (TR) at each floor.
- * The pathways carries telecommunications cables from the TR to the vicinity of the area served



Horizontal cabling of the telecommunication cabling system consists of two or more cables that are connect to each work area from a Telecommunication room.

- * Each cable is terminated at the cross-connection field in the TR.
- * It can transmit both voice and data applications.

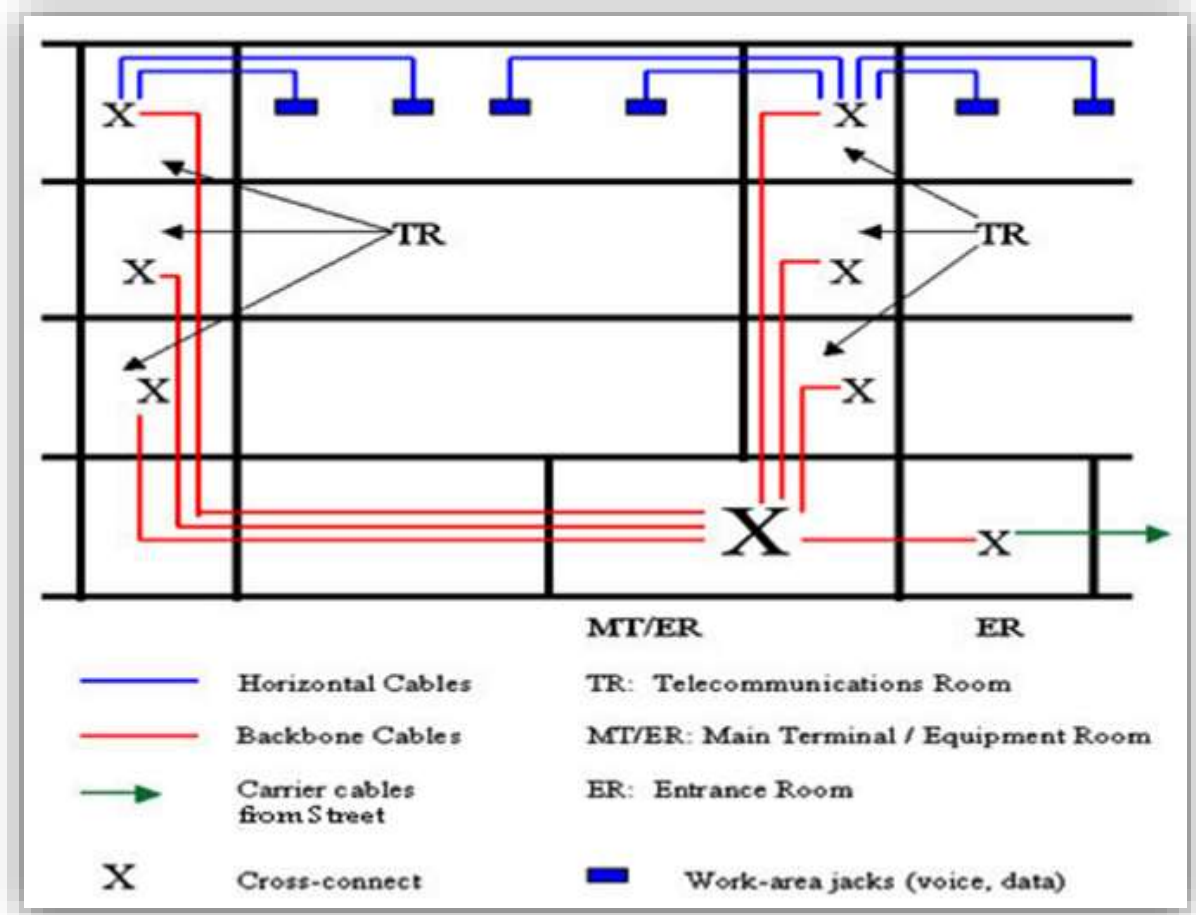

VOICE AND DATA COMMUNICATION:

Data Compression

- If a typical message were statistically analyzed, it would be found that certain characters are used much more frequently than others.
- By analyzing a message before it is transmitted, short binary codes may be assigned to frequently used characters and longer codes to rarely used characters.
- In doing so, it is possible to reduce the total number of characters sent without altering the information in the message.
- Appropriate decoding at the receiver will restore the message to its original form. This procedure, known as data compression, may result in a 50 percent or greater savings in the amount of data transmitted.

Data Encryption:

- Privacy is a great concern in data communications. The important messages that are sent can be hacked without the knowledge of sender and receiver.
- To increase the security for data communications including digitized telephone conversations, the data will be encoded and sent to the receiver.

- Authorized receiver stations will be equipped with a decoder that enables the message to be restored. The process of encoding, transmitting, and decoding is known as encryption.

COMPUTER LABS/ SERVER ROOMS:

Virtually every modern business needs servers to run their website, manage email, or deploy cloud applications.

The first aspect to consider when setting up a server room in your office is where the servers will be located. Finding suitable space within a company's existing property for an onsite server room can be an expensive proposition, often requiring significant remodeling and potentially the construction of a custom space.

The location must be suitable for the installation of bulky power, air conditioning, and networking equipment. It must be able to bear the weight of heavy equipment. Tight spaces aren't suitable because effective cooling requires the constant circulation of air. It's also inadvisable to build a server room in a windowed space or a space with an external wall, both of which can make it difficult to control and secure the environment within the server room.

Ideally, the space's ceilings should be at least nine feet from the ground, and raised ceilings are preferred to allow for the running of air ducts and installation of heat exhausts and other equipment. Raised floors that allow for cable runs are also a bonus, but not necessary for smaller server rooms.

Above all, a server room must be secure, with monitored and controlled access from within the building and from external areas.

Server Room Equipment

Once a location has been selected, it's time to consider the equipment that is to be purchased and fitted. Much of the expense associated with building a server room is generated by the equipment needed to support servers, rather than the servers themselves.

Air Conditioning

Air conditioning for server rooms has three main tasks:

Maintenance of stable temperatures in the server room.

Humidity control: servers don't do well in humid environments.

Air filtration: dust and other airborne particles can reduce the lifespan and reliability of computing equipment.

Typically, smaller server rooms will use wall-mounted air conditioners. For larger rooms under-ceiling units are preferable.

Temperatures within a server room should be approximately 71°F (22°C). Modern servers will function at higher temperatures, but with an increased likelihood of component failure.

Fire Suppression

Servers represent a significant capital investment even before the data stored on them is taken into account. Server room fire suppression equipment uses gas or chemical suppression techniques to automatically extinguish fires. Most fire suppression systems require pressure relief venting to be fitted to server rooms to mitigate pressure changes during discharge.

Racks

Modern servers are designed to be mounted in racks. Servers are available in a wide range of sizes, expressed as multiples of a rack unit (or “U”). The smallest server rooms will require at least one cabinet or rack, which will contain space for servers. The larger the server deployment, the more racks and cages you’ll need.

Networking

Depending on the number of servers the server room will house, you can expect to require:

- core routers
- switches
- appropriate cabling

Networking equipment should be housed in a secure equipment rack within the server room. The type of networking equipment needed depends on the number of servers, the desired levels of redundancy, and a number of other factors.

Larger server rooms require dedicated routers; Cisco and Juniper are the leading manufacturers of networking equipment. Businesses that depend on the reliability of their server room should choose to double-up on networking equipment for redundancy.

Power

Your server room requires a reliable power supply. At minimum the server room requires a utility power source, but plugging servers directly into utility power is not a good idea.

For reliability, an Uninterruptible Power Supply (UPS) is required. A UPS provides emergency power for short periods in the event of a mains power failure. Servers need a consistent supply of power and mains power is prone to occasional brownouts or blackouts. Without a UPS, servers are at risk of data corruption, equipment damage, and availability issues.

The UPS typically provides power to a power distribution unit (PDU) mounted within the server rack that houses the servers they power.

Once again, redundancy is an important concern here. A UPS is only a temporary solution to power outages, and for optimal reliability, multiple power sources that include an on-site generator are preferred.

Security

Security should be a core priority, especially if an organization stores and processes sensitive data. Server room security is a major component of most regulatory frameworks governing data storage, including HIPAA for private medical data and PCI DSS for credit card data.

Physical security equipment required might include:

- Heavy duty doors with electronic locks.
- CCTV monitoring of the server room and adjacent areas.
- Biometric or security card access controls.

Server rooms should not be accessible from the outside of the building and should not have windows. Only authorized personnel should have access to the server room and all access should be monitored and logged.

AR3603 ADVANCED BUILDING SERVICES
Semester VIth (Regulation 2021)
Two Marks with answer

UNIT - I PRINCIPLES AND SYSTEMS OF AIR CONDITIONING

1. Discuss Vapour compression cycle in brief. (APR/MAY 2023)

It is a compression process, whose aim is to raise the refrigerant pressure, as it flows from an evaporator. The high-pressure refrigerant flows through a condenser/heat exchanger before attaining the initial low pressure and going back to the evaporator.

2. Define the term Condenser. (APR/MAY 2023)

A condenser is a vessel or stage which turns a vapor into a liquid. A compressor is used to pump that vapor to a condenser, where the vapor turns back into a liquid, ready for reuse. Condensers are special heat exchangers that remove the heat of vaporization from steam

3. Give any two properties of refrigerant. (NOV/DEC 2022)

- Low boiling point.
- High latent heat value.
- Low freezing point.
- Non-flammable and non-toxic

4. State the role of a compressor in the refrigeration cycle (NOV/DEC 2022)(APR/MAY 2018)

At its essence, the compressor's role involves **compressing the refrigerant gas, which subsequently increases its pressure and temperature.** To visualize it, the compressor inhales a gas with low pressure and low temperature and exhales a gas with high pressure and high temperature

5. Write a note on AHU. (APR/MAY 2021)

The air handling unit (AHU) is **the heart of central air conditioning.** It collects outside air and room air, removes dust and other particles from the collected air, adjusts the temperature and humidity and then supplies comfortable and refreshing air-conditioned air into the rooms through ducts.

6. What is a refrigerant? Give an example. (APR/MAY 2021)

A refrigerant is a **working fluid used in the refrigeration cycle of air conditioning systems and heat pumps.**

Ex: fluorocarbons, especially chlorofluorocarbons (CFC's),

7. What is thermodynamics? (APR/MAY 2018) (NOV/DEC 2017)

Thermodynamics is **the study of the relations between heat, work, temperature, and energy.** The laws of thermodynamics describe how the energy in a system changes and whether the system can perform useful work on its surroundings.

8. Define latent heat of fusion. (NOV/DEC 2014) (NOV/DEC 2015) (APR/MAY 2018)

The amount of heat energy that is required to change 1 kg of solid into liquid at atmospheric pressure at its melting point is known as the latent heat of fusion.

9. What is latent heat of evaporation? (NOV/DEC 2017)

“The amount of heat that is needed to convert a unit mass of liquid substance into a gaseous phase at constant temperature conditions is known as latent heat of vaporization.”

10. Describes the significant of vapour compression cycle. (APR/MAY 2017)

Vapor compression cycles (VCC) are the most widely used cooling systems, including air conditioning and refrigeration applications. Although it is not waste heat recovery technology, it is worth mentioning for two reasons. For one, **it dominates cooling demands fulfillments in ship applications.**

Part B Questions

1. Demonstrate the working principles of split and direct expansion system with neat sketches, and also examine the pros and cons of both the air conditioning systems. **(20) (APR/MAY 2023)**
2. How does a Chilled Water Systems Work? Explain with neat sketches. **(APR/MAY 2023) (20)**
3. Explain about the energy efficient techniques followed in Air Conditioning of office buildings with examples and sketches. **(NOV/DEC 2022)**
4. Explain Vapor Compression type refrigeration cycle along with the flow diagram and its typical applications in air cooled system and water cooled system. **(NOV/DEC 2022)**
5. Explain the vapour compression cycle, Write the differences between a window and split ac unit. **(20) (APR/MAY 2021)**

6. Write a note on the following with suitable sketches: (APR/MAY 2021)

i) Direct expansion system. (10)

ii) District cooling systems. (10)

UNIT - II DESIGN ASPECTS OF AIR CONDITIONING SYSTEMS

1. List any four types of Air Conditioning System. (APR/MAY 2023)

- Central Air Conditioner.
- Ductless Mini-Split.
- Window Air Conditioner.
- Portable Air Conditioner.
- Floor-Mounted Air Conditioner.
- Smart Air Conditioner.

2. Mention any two advantages of District cooling system over Traditional cooling system. (APR/MAY 2023)

Advantages for customers with district cooling are the requirement for **less space for cooling equipment inside the building, less operation and maintenance costs, and less electricity cost.** The subscribed cooling capacity can also be adjusted to the actual measured customer cooling demand.

3. Differentiate between sensible heat and latent heat. (NOV/DEC 2022) (NOV/DEC 2017)

s.no	Latent heat	Sensible heat
1	Latent heat is the amount of energy that is either absorbed or released during a phase transition at a constant temperature	Sensible heat is the energy required to change the temperature of a substance with no phase change
2	Defined for a system with phase transition	Defined for a system without phase transition
3	Describes the changes in the internal energy of matter	Describes the energy exchange between matter and surroundings
4	Related to a system at a constant temperature	Related to a system with changes in temperature

4. What is the relation between Ton of Refrigeration and BTU? (NOV/DEC 2022)

One refrigeration ton is equivalent to 12000 BTUs per hour. In other words, a refrigeration system with a cooling capacity of one ton can remove 12000 BTUs of heat per hour. This relationship can be expressed mathematically as: $1 \text{ RT} = 12000 \text{ BTU/hr}$.

5. State any four factors that determine the choice of the refrigeration system in an operation theatre. (APR/MAY 2021)

1. safety
2. environmental impact
3. energy efficiency
4. cost-effectiveness.

6. Sketch the location of a vertical duct and the horizontal ducts in a room measuring 70m x 50m. (APR/MAY 2021)

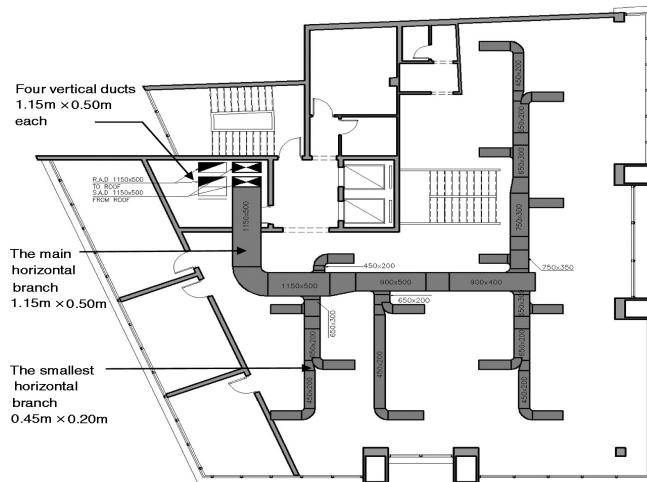

7. List the conditions for positioning an AHU room in a multi-storeyed building. (NOV/DEC 2017)

In short, an air handling unit is a huge indoor unit of commercial air conditioning equipment. This massive “indoor unit” is installed **on a rooftop or along an external building wall**. It produces cool/warm air and sends it to the rooms for cooling/heating.

9. Express the term ton of refrigeration. (MAY/JUNE 2013)(NOV/DEC 2016)

A ton of refrigeration (1 TR) is defined as **the amount of heat, which is to be extracted from one tonne of water at 00C in order to convert into ice at 00C in 24 hours (1 day)**. $1 \text{ TR} = 210 \text{ kJ/min} = 3.5 \text{ kW}$

10. Give the types of cooling system used in large buildings. (NOV/DEC 2017)

- Packaged spilt system
- Room air-conditioner
- Evaporating cooling
- Heat pumps
- chillers

Part B Questions

1. (i) What is the function of an egress system? What are the components of an egress system? (10)
- (ii) Illustrate the general guidelines for egress design for multi-storey buildings (10) (APR/MAY 2023)

2. (i) Explain the design guidelines as per NBC for installing a fire lift in multi-storey buildings (10) (APR/MAY 2023)

3. (i) What is Air handling unit (A.H.U)? Mention the criterion to be considered for locating AHU in a multi-storey building?(8) (NOV/DEC 2022)

(ii) Explain the arrangement of AHU along with the location of chilled water plant, cooling tower and air handling unit with schematic drawings. (12) (NOV/DEC 2022)

4. Outline the principles considered for grouping and integrating horizontal and vertical distribution of all services in a multi-storied office building. (12)

UNIT - III FIRE SAFETY

1. Sketch the triangle of fire. (APR/MAY 2023)

Fire Triangle : The Fire Triangle is a simple way of understanding the components of fire. Each side of the triangle represents one of three components needed to have a fire – oxygen, fuel and heat. Fire is a chemical reaction and without one of these components, fire cannot exist or be sustained.

2. What are the four stages of fire? (NOV/DEC 2022)

There are four stages of fire development: ignition, growth, fully developed, and decay. The ignition stage is when all four elements of the fire tetrahedron coalesce, the fuels reach their ignition temperature, and the fire begins

3. Mention any two exit requirements as specified by NBC of India. (NOV/DEC 2022)

At least two separate exits should be accessible from every part of every floor, including basements; such exits should be as remote from each other as practicable and so arranged as to be reached by different paths

4. Write a note on smoke detectors. (APR/MAY 2021)

A smoke detector is an electronic fire-protection device that automatically senses the presence of smoke, as a key indication of fire, and sounds a warning to building occupants. Commercial and industrial smoke detectors issue a signal to a fire alarm control panel as part of a building's central fire alarm system.

5. What are the types of fire hydrants? (APR/MAY 2021)

Dry barrel and wet barrel are the two kinds of Fire Hydrants. The wet barrel fire hydrant holds a constant water supply, while the dry barrel fire hydrant needs to have a valve release to let water in. It is designed to provide rapid access to water in the event that a fire breaks out.

6. What is fire drill ? (APR/MAY 2018)

A fire drill is a method of practicing how a building should be evacuated in the event of a fire or other emergencies.

7. Write briefly about fire detection and firefighting systems. (APR/MAY 2017)

- A fire detection system is an electronic system made up of different types of devices and whose objective is to preventively detect a fire in its most incipient phase, and to issue alarm signals to the user personnel of the installation to try to prevent it from spreading.
- A fire fighting system is an activity of prevention during a fire spread in building, home or warehouse with the use of proper fire safety equipment like extinguisher, hose reels, fire monitors, nozzles and hose pipes.

8. Explain about fire safety design principles. (APR/MAY 2017)

Most of the current guidelines across the world contain detailed design requirements for fire safety such as **evacuation routes, compartmentation, and structural fire design**. However, most old buildings do not conform to the latest guidelines for fire safety design, they become particularly vulnerable when fire happens.

9. Describe fire resistance. (NOV/DEC 2017)

Fire resistance is **the property of materials or their assemblies that prevents or retards the passage of excessive heat, hot gasses or flames under conditions of use** (NYCBC, 2008). Fire resistance of materials is quantified by means of fire resistance rating.

10. What do you mean by fire compartmentation? Explain with sketches. (NOV/DEC 2017)

Correctly implemented fire compartmentation involves dividing an area into sections, which in turn allows the fire to be contained into one area of the building. This then allows fire crews to safely extinguish the fire whilst it is contained.

Part B Questions

1. (i) Explain how a fire alarm works in case of emergency with necessary sketches. (10) (APR/MAY 2023)
2. Explain how a fire alarm works in case of emergency with necessary sketches. (10) (APR/MAY 2023)
3. Enlist the types of fire suppressions systems. Explain any two types of fire suppressions systems that can be used in commercial building. (NOV/DEC 2022)
4. Enlist various fire alarm and fire protection system used in a building. Explain any two widely used fire protection system in building. (NOV/DEC 2022)
5. Discuss the various strategies that need to be incorporated at the site level, in buildings including the services to fight fire accidents in a ten storied building. (APR/MAY 2021)
6. A commercial building with six floors needs to be air conditioned. Explain the refrigeration system you would advocate for air conditioning with reasons. (APR/MAY 2021)

UNIT - IV MECHANICAL COMMUNICATION AND SECURITY SYSTEM**1. Brief your understanding about "Building Automation System".(APR/MAY 2023)**

Building automation is the use of automation and control systems to monitor and control buildingwide systems, such as HVAC, lighting, alarms, and security access and cameras.

2.what does round trip time of a lift means ? (APR/MAY 2023)

The round trip time is defined as the time taken for the elevator to pick up the. passengers from the main lobby, travel to the upper floors and deliver them. Passengers to their destinations and then express back to the main terminal again to. pick up more passengers.

3. List the types of Escalators and its applications. (NOV/DEC 2022)

- Moving Walkways. A moving walkway or sidewalk is a conveyor transport system that automatically carries pedestrians.
- Parallel Escalator.
- Stairway Escalators.
- Belt-Type Escalators.
- Curved Escalators.
- Wheelchair-Accessible Escalator.
- Step Type Escalator
- Crisscross Escalator.

Applications:

department stores, shopping malls, airports, transit systems (railway/railroad stations), convention centers, hotels, arenas, stadiums and public buildings.

4. Mention the elements that make up the means of egress. (NOV/DEC 2022)

A means of egress may include horizontal and vertical travel routes including intervening rooms, spaces, doorways, hallways, corridors, passage-ways, balconies, ramps, stairs, enclosures, lobbies, escalators, courts and yards

5. List any six components of an escalator. (APR/MAY 2021)

A unit to drive the escalator, comprised of **electric motor, decelerator, electromagnetic brake, V belt, Sprocket, and other components.**

6. How RTT is calculated? (APR/MAY 2021)

The propagation delay is usually the dominant component in RTT and you can get a good estimate of RTT by a simple formula: $RTT = 2 \times \text{Propagation delay}$. You should also understand that it generally takes more than a single request to load the entire page.

7. What are the types of elevators? (APR/MAY 2018)

Here are four main types of elevators: **hydraulic, traction, machine-room-less, and vacuum.**

8. What is the function of dump waiters? (NOV/DEC 2018)

It's a small lift (most often waist-height) used **to bring food up to a restaurant from kitchens below and to take dirty dishes back down from the dining room** – a hidden and essential device in almost every mansion, café and restaurant

9. What are the latest systems involved in security systems? (APR/MAY 2017)

- Video surveillance
- Alarm systems
- cameras

10. List the types of lifts and its applications. (NOV/DEC 2017)

The main types of commercial lifts are **passenger lifts, goods lifts, wheelchair or disabled access lifts and scissor lifts.** Each type of lift uses a specific lifting mechanism, which will depend on the lift height, weight capacity and power required.

Part B Questions

1. Differentiate between hydraulic and traction lift with necessary sketches **(10) (APR/MAY 2023)**
2. Discuss the factors influencing lobby design in a hotel design, with sketches. **(10) (APR/MAY 2023)**
3. Discuss about parallel and criss-cross elevators with sketches. **(10) (APR/MAY 2023)**
4. Explain with sketches, why Escalators are considered more advantageous than lifts during peak flow of passenger traffic **(10) (APR/MAY 2023)**

5. A multi-storied hospital lobby is to be designed with 4 passenger lift of 8 capacity each, 2 bed lift and an adjoining waiting area. Sketch/Draft the plan of the hospital lobby, showing the lift configuration and optimum circulation area. (Mention lift dimensions, consider wheel-chair users and assume other necessary datas. (NOV/DEC 2022)
6. Mention and explain the various building automation systems that can be used in a modern building, their benefits and integration methods. (NOV/DEC 2022)
7. Outline how round trip time and waiting time is used in designing and planning of lifts in buildings. (8) (NOV/DEC 2022)
8. Discuss the pre requisites for installing parallel and crisscross escalators in an atrium of an office complex. (APR/MAY 2021)
9. Explain the working principle of the traction lift installed in a G + 3 apartments with suitable sketches. (APR/MAY 2021)

UNIT - V INTEGRATION OF SERVICES INTO ARCHITECTURAL DESIGN

1. What does "Round trip time" of a lift means? (APR/MAY 2023)

The round trip time is defined as the time taken for the elevator to pick up the passengers from the main lobby, travel to the upper floors and deliver the passengers to their destinations and then express back to the main terminal again to pick up more passengers.

2. What is a dumb elevator? (APR/MAY 2023)

A residential dumbwaiter is likely to be smaller than those designed for commercial spaces, and they'll require less capacity. Typically a dumbwaiter lift sizes for residential use will come in at around 750mm x 750mm, with a capacity of 50kg.

4. Mention any two measures to be adopted to protect the AC systems against Fire. (NOV/DEC 2022)

Interior AC coils are to be cleaned and air filters are to be replaced regularly. This will prevent the fan motor from being overworked. 2. Keep the space around your unit free and clear with Jaom terany materials or debris at least 3 feet away.

5. Sketch a typical cross section of the electrical and mechanical services above the false ceiling in a commercial complex. (APR/MAY 2021)

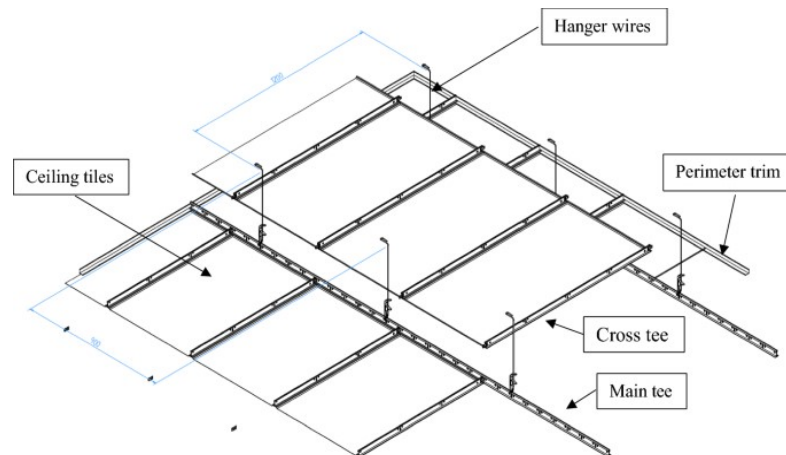

6. Explain the role of service core in MSBs. (APR/MAY 2021)

MSB Core One Service is our team of experienced gas technicians, refrigeration mechanics, steamfitters, oil burner technicians, control technicians.

Part B Questions

1. A Hotel building of 4 floors with a banquet hall and lodging rooms need to be air-conditioned. Suggest an appropriate air conditioning system and justify your answer by listing the criteria's for selection. (10) (APR/MAY 2023)
2. Draw a vertical section and show AHU room position in each floor and write the step by step procedure for calculating Duct size. (10) (APR/MAY 2023)
3. Explain the ways through which the electrical and communication systems are integrated in a 15 m height building. (APR/MAY 2021)
4. What is BAS? Discuss the advantages of integrating BAS in an IT park. (APR/MAY 2021)
5. Outline the horizontal distribution of ducts over ceiling and raised floors with sketches. Explain the characteristics of ducts used for air-conditioning based on their shape, size and layout. (NOV/DEC 2022)

*****ALL THE BEST*****